

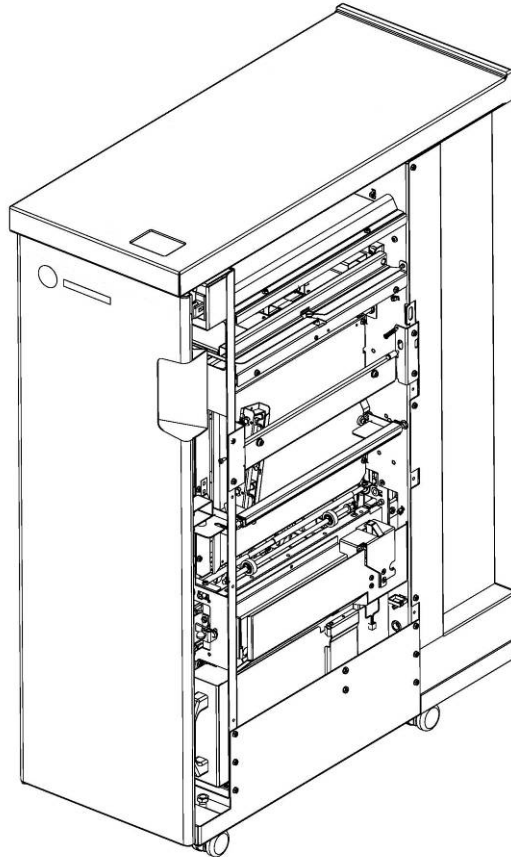

# Ricoh StreamPunch™ Pro, Pro EX & MP

## Installation Manual



<b>Contents</b>	<b>Page</b>
1. Recommendations and Pre-requisites	2
2. Unpacking	2
3. Cable Connections	2
4. Installing the Sound Deadening Foam	5
5. Docking Bracket Installation	7
6. Leveling & Height Adjustment	8
7. Final Steps	9



ACCO Brands, Inc.  
Four Corporate Drive  
Lake Zurich, IL 60047  
www.acco.com

Part No. 7712832  
Rev No. K1  
Issue Date: April 11, 2014

## 1. Recommendations and Pre-requisites

- You will need the installation kit provided with the StreamPunch unit, which can be found in the main carton.
- If installing the StreamPunch downstream from a BK5000 Booklet Maker, a cover kit is required. (Part No US – 404282EDP, EU – 961462EDP, AUS – 7708997)
- Using a jogging unit on the finisher will improve the stack quality for binding purposes.
- If installing the StreamPunch directly downstream of Pro C900 series, Pro C651/C751 EX or Pro C751, contact your local service representative to obtain the correct entrance guide.

## 2. Unpacking

- Inspect the outside of the package for shipping damage. If there is evidence of shipping damage, contact the shipping carrier immediately.
- Remove the punch from its shipping carton. Three people are recommended, one lifting at the casters while two lift at the top cover. DO NOT lift using the front door panel.
- Retain the smaller accessory box; it contains parts required for correct installation of the StreamPunch.
- Inspect for any concealed damage to the unit. If there is evidence of concealed shipping damage, contact the shipping carrier immediately.
- Remove all shipping tape from doors and levers.

## 3. Cable Connections

Review the table below to identify which section of the guide to refer to install the StreamPunch Pro/ Pro EX/ MP.

Section	Printers	Finisher
<b>3.1</b>	Pro C900 series, Pro C550/700 & MPC6501/7501	SR5000
<b>3.2</b>	MP6001/7001/8001/9001	SR4050
<b>3.2</b>	MP6002/7502/9002	SR4080
<b>3.3</b>	Pro 907/1107/1357EX	SR5020
<b>3.3</b>	Pro C651 EX & Pro C751 EX	SR5030/ SR5040
<b>3.3</b>	MP C8002/ C6502 & Pro C5100S/ C5110S	SR4110
<b>3.3</b>	Pro 8100S/8110S/8120S	SR5050/ SR5060

Refer to the following section when installing the SK5010 downstream of the StreamPunch Pro.

<b>3.4</b>	High Capacity Stacker	SK5010
------------	-----------------------	--------

### 3.1 SR5000 Finisher

The cables below are required to attach the StreamPunch Pro to this type of finisher.

Finisher to StreamPunch cable  
p/n VR340046



Finisher to printer cable (longer version)  
p/n VRC57001



a)

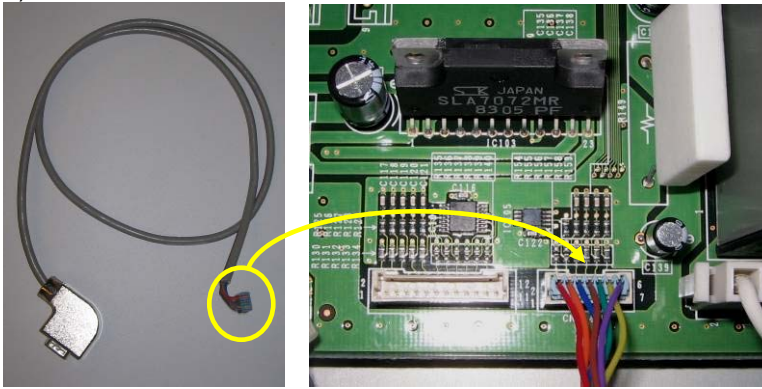

Remove the finisher rear cover and plug the 7 pin communication cable to CN144 in the bottom left corner of the SR5000 finisher board.

b)

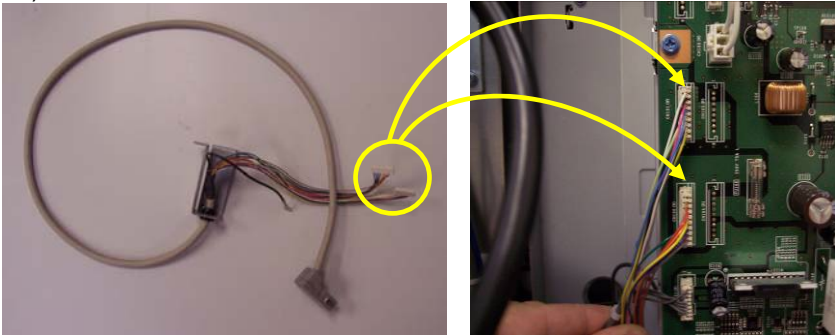

Replace the finisher to printer cable with the longer cable provided. Plug the 8 & 9 pin connector's into CN100 & CN101 on the finisher board. Replace the finisher rear cover.

c)



Plug the free end of the cable from step a) into the right side of the StreamPunch. Plug the free end of the cable from step b) into the connector on the printer.

d) There are two entrance paper guides provided with the StreamPunch. Use the longer paper guide measuring about 14" long when used in conjunction with the SR5000 finisher. Install the paper guide, using the size #8 screws provided, to the lower entrance guide of the StreamPunch.

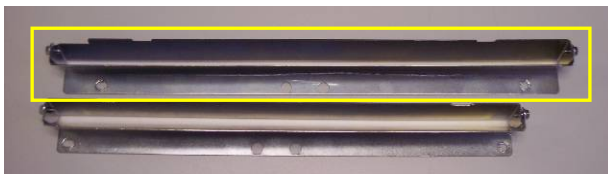

If installing the StreamPunch directly downstream from the printer, contact your local service representative to obtain the correct entrance guide.

Go to Section 4 to complete the installation.

### 3.2 SR4050 & SR4080 Finisher

Follow the same steps as in 3.1 but in step a) connect the 7 pin connector into CN138 on the finisher board.

d) There are two entrance paper guides provided with the StreamPunch. Use the shorter paper guide measuring about 12" long when used in conjunction with the SR4050 finisher. Install the paper guide, using the size #8 screws provided, to the lower entrance guide of the StreamPunch.

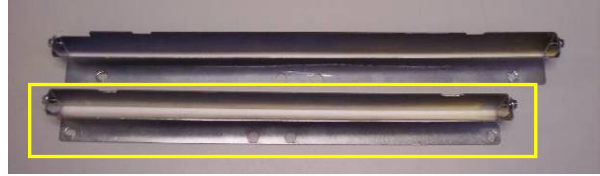

Go to Section 4 to complete the installation.

### 3.3 SR5020, SR5030, SR5040, SR5050, SR5060 Finishers

Follow the same steps as in 3.1 but in step a) connect the 7 pin connector into CN110 on the finisher board.

d) There are two entrance paper guides provided with the StreamPunch. Use the longer paper guide measuring about 14" long when used in conjunction with the SR5020, SR5030 or SR5040 finishers. Install the paper guide, using the size #8 screws provided, to the lower entrance guide of the StreamPunch.

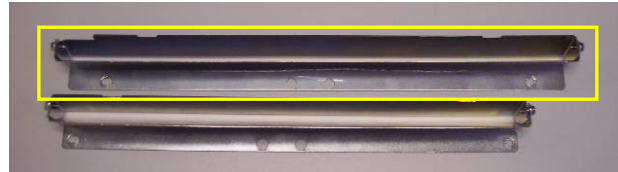

If installing the StreamPunch directly downstream from the Pro C651/C751 EX or Pro C751, contact your local service representative to obtain the correct entrance guide.

Go to Section 4 to complete the installation.

### 3.4 SK5010 High Capacity Stacker

Follow the same steps as in 3.1 but in step a) connect the 7 pin connector into CN150 on the finisher board and in step b) replace the shorter finisher to printer cable with the longer one provided, plugging the 8 pin cable in to loose connector and the 9 pin into CN101 on the finisher board.

There are two lower exit guides that can be used with the StreamPunch. The standard 90 degree bend is used for most configurations and comes ready installed. When the SK5010 is installed directly downstream from the StreamPunch, the angled guide shown below should be fitted in place of the 90 degree guide. The angled exit guide is provided with the installation kit.

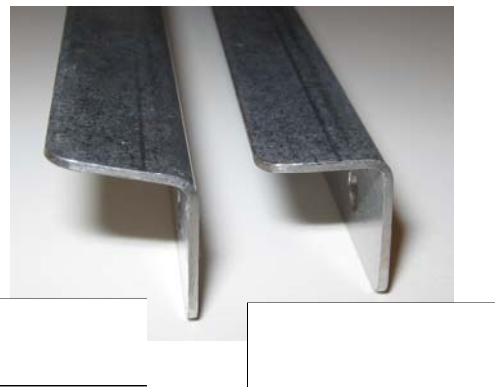
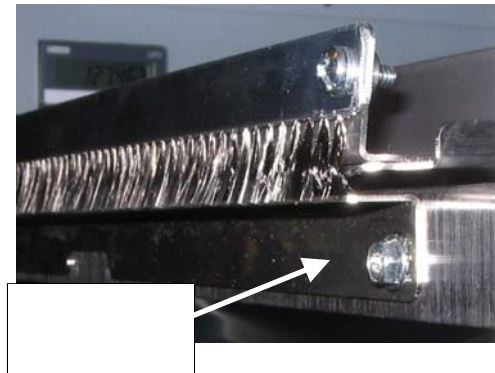

## 4. Installing the Sound Deadening Foam



Supplied with the StreamPunch, you will find six strips of sound deadening foam are shipped loose for field installation. These are not attached at the factory to avoid compression and/or damage during shipping.



To install, simply peel the back off to reveal the adhesive using the following steps as a reference.

### 4.1 Paper Exit Side (Finisher Side)



Apply the wide strip to the right side as shown.



Apply one of the two shorter pieces to the side of the top cover as shown.



Apply one of the three longer strips to the left rear panel as shown.



Exit side complete

#### 4.2 Paper Entrance Side (Printer Side)



Apply one of the two remaining long strips to the right side of the printer side of the StreamPunch as shown.



Apply the last remaining short strip to the top cover edge of the printer side of the StreamPunch as shown.



Apply the last remaining long strip to the left side of the printer side of the StreamPunch as shown.

## 5. Docking Bracket Installation



The docking brackets are shipped in a separate bag along with size M4 mounting screws (not shown). There are 2 lengths supplied. You may need to use the longer screws for some printers when installing without the buffer pass unit. The brackets have a number 2 stamped in the bottom corner.

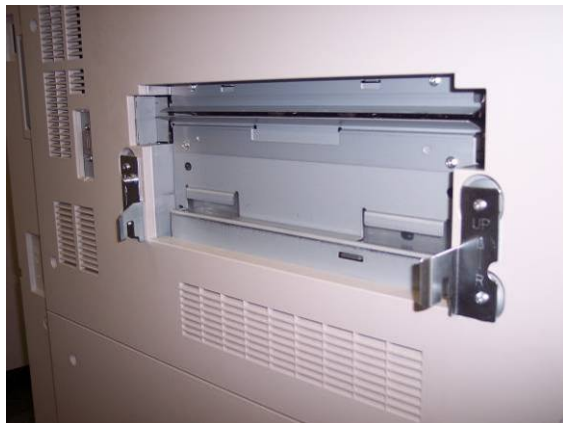

Install as shown with the bracket marked "R" on the right side facing you as you look at the exit side of the upstream device. Install the bracket marked "L" on the left side facing you. Both brackets should be oriented with the arrow facing up.



Before the system can be docked correctly the paper guide on the finisher needs to be removed. This is not used on the finisher when in line with the StreamPunch.

The docking bracket(s) provided with the finisher should be attached to the downstream side of the StreamPunch with 4 size M4 screws.

## 6. Leveling & Height Adjustment

### 6.1 Height Setting

No height adjustment of the StreamPunch is required, for an installation site with a level floor, when docking upstream of the SR4050, SR5020, SK5010 or SR5030. If the floor is uneven then it is recommended to set the level of the StreamPunch using the downstream device as a reference. The exit guide of the StreamPunch should be set as shown below for the various finisher types. When installing the StreamPunch upstream of the SK5000, the StreamPunch will need to be lowered by approximately 5mm. Follow the same adjustment procedure as in Section 6.2 and use the table below for a reference height.

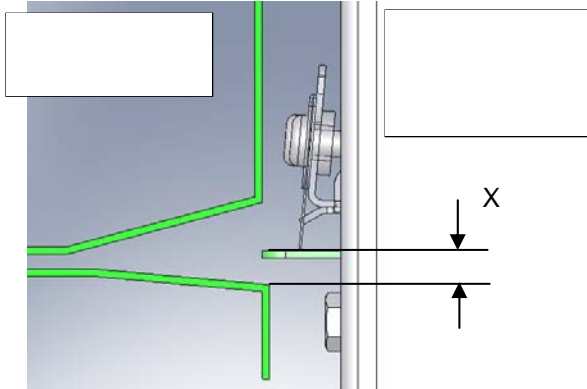

Finisher	Reference Height X
SR5000	4mm
SR4050/SR4080	4mm
SR5020	3mm
SR5030/ SR5040	3mm
SK5000*	2.5mm

\* Height adjustment required

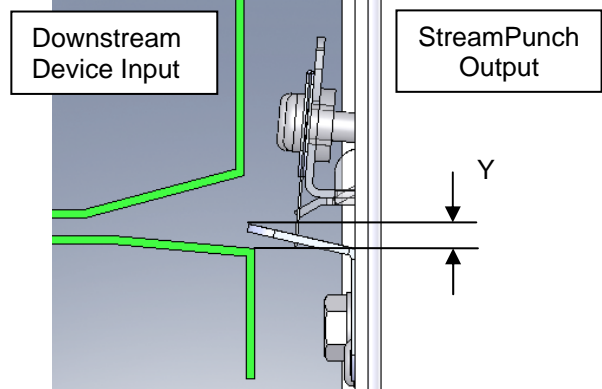

Finisher	Reference Height Y
SK5010	2.5mm

### 6.2 Adjusting the Casters

a)



Using a 9/16" (15mm) open ended wrench, loosen the jam nut(s) situated on the caster stud inside of the machine.

b)



Using the 9/16" (15mm) wrench, rotate the caster stems to change the height.

Re-tighten the jam nuts once the correct height is achieved.



## 7. Final Steps

### 7.1 Printer & Finisher Firmware

Confirm that the printer and finisher have the latest firmware installed. Firmware is available for download at [www.tscweb.net](http://www.tscweb.net) (US) or [www.ricoh-support.com/techuser/](http://www.ricoh-support.com/techuser/) (EU) or can be obtained by contacting Ricoh service.

Special custom engine firmware must be installed if installing the StreamPunch with the Martini-C4 (MP 6001/7001/8001/9001).

### 7.2 Setting the Dip Switch

If the unit is fitted with a dip-switch then the setting should be changed depending on the printer it is attached to. If present, the dip-switch is located next to the firmware upload connector on the rear cover. If the dip-switch is not present then no setting is required. Set the dip-switch per the table below.

Printer	Dip Switch Setting							
	1	2	3	4	5	6	7	8
Pro 907/1107/1357EX	OFF	ON	ON	ON	ON	ON	ON	OFF
Pro C900 series	OFF	ON	ON	OFF	OFF	ON	ON	OFF
Pro C550/700, MPC6501/7501	OFF	ON	ON	ON	OFF	ON	ON	OFF
MP6001/7001/8001/9001	OFF	ON	ON	OFF	ON	ON	ON	OFF
Pro C651/751 EX, Pro C751	OFF	ON	ON	ON	ON	OFF	ON	OFF
MP6002/7502/9002	OFF	ON	ON	OFF	ON	ON	OFF	OFF
MP C8002/ Pro C5100s	OFF	ON	ON	OFF	ON	OFF	ON	OFF
Pro 8100S/8110S/8120S	OFF	ON	ON	OFF	OFF	OFF	ON	OFF

### 7.3 Enabling the Punch Icon

If the punch icon (shown below) for the StreamPunch option does not appear on the operation panel, follow the procedure below:

- Select User Tools
- Select Copier/Document Server Features
- Select Input/Output Tab
- Select Punch Type-Top Option
- Select Item-one on the left
- Select Punch Type-Multiple Hole: Left
- Exit

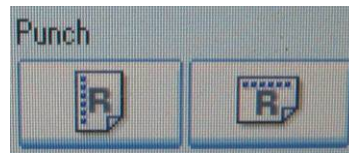

Note: If the punch option will not enable due to paper size or direction, change the Original Orientation (lower left corner of the copier Operation Panel).

### 7.4 Functional Test

Functional test the StreamPunch system

- Check to ensure that the paper chip tray is securely in place.
- Check to ensure that a die set is installed properly and that any extra die sets are securely stored in the die storage area.
- Run a small test job in "Bypass" mode. Check to ensure that the job is not punched and bypasses properly.
- Run a small job with punch enabled. Check the punched holes of the job.
- Run each die set to punch 100 sheets or until there is no oil residue around the holes.