

Part Number: 7726039

Revision: 1

Issue Date: October 2025

Notice

All service documentation is supplied to external customers for informational purposes only. Service documentation is intended for use by certified, product trained service personnel only. GBC does not warrant or represent that such documentation is complete. GBC does not warrant or represent that it will notify or provide to such customer any future changes to this documentation. Service by the customer of the equipment, or modules, components, or parts of such equipment may void any otherwise applicable GBC warranties. If customer services such equipment, modules, components, or parts thereof, Customer releases GBC from any and all liability for actions by the Customer, and Customer agrees to indemnify, defend, and hold GBC harmless from any third party claims which arise directly or indirectly from such service.

Changes are periodically made to this document. Changes, technical inaccuracies, and typographic errors will be corrected in subsequent editions.

Revision History

Date	Revision	Description
October 2025	1	Initial draft

Copyright Notice

GBC
ACCO Brands Inc.
Four Corporate Drive
Lake Zurich, IL 60047. USA

© Copyright 2025 by ACCO Brands Inc. All Rights reserved.

No part of this document may be photocopied or reproduced by any means, or translated to another language without prior written consent of GBC.

All brand names, trademarks and registered trademarks are the property of their respective owners. Information contained within this document is subject to change without notice.

Contents

Safety	1
Safety Devices	1
Operational Safety	2
Important Safeguards	2
Introduction	3
Glossary of Acronyms	4
Specifications	5
Media Input from Printer	5
Serial Number	5
Supplies	5
User Interface	6
Home	6
Settings	7
User Functions	8
Cycle Cutter	8
Trim Film and Eject	8
Film Proof Test	8
Center Alignment	8
Margin	8
Skew	8
First Sheet	9
Language & Units	9
Cut Stick	9
Info	9
Laminator Cycles	9
Firmware	9
Service Menu	10
User Functions	11
Cutter Blade	11
Sensors	11
Motors	11
Solenoids	12
Function Tests	12
Files	13
Options 1	13
Options 2	13
Alignment Offsets	13
Printers	13
Firmware Update / Save Logs	14

Max Bypass.....	15
Service Call Procedures	16
Tools Needed	17
Preventive Maintenance	17
Schedule	17
Cleaning.....	19
Exterior	19
Interior	19
Base	19
Trim Tray	20
Idler Roller.....	20
Steering Idler Roller and Springs	21
Drive Rollers.....	22
Steering Drive Rollers	23
Pressure Roller.....	24
Optical Sensor	26
Exit Panel (Inner).....	27
Bypass Paper Path.....	28
Lamination Paper Path.....	29
Solenoid	30
Alignment Carriage Rails.....	32
Cutter Clutch	33
Cutter Out-feed Baffle	35
Cutter Blade	36
Diverter Solenoid (SOL1) Assembly.....	37
Trim Diverter.....	38
Trim Diverter Solenoid (SOL8).....	39
Chip Reader	40
Inspection	41
Door Latch	41
Idler Roller and Idler Springs.....	42
Panel Latch	43
Paper Path Timing Belt	44
Cutter Blade	45
Cut Stick.....	46
Cartridge Rail	47
Cartridge Tray	48
Cartridge Frame	49
Troubleshooting	50
Initial Troubleshooting.....	52
Advanced Jam Clearing.....	53
Roller Wraps.....	53

Lamination Quality	54
Film Refill.....	54
White Rings	54
Hub Position	54
Paper Position	54
Center Alignment.....	54
Margin	55
Skew.....	56
Film Alignment.....	57
Pressure Roller Line.....	57
Wrinkles.....	58
Paper.....	58
Film.....	58
Curl.....	59
Cross Path.....	59
Film Flow	59
Poorly Sealed Edge.....	59
Incomplete Cuts	59
Angled Cuts.....	60
Bubbles / Trapped Particles	60
Dog Ears	61
Adhesive Marks.....	61
Operator Messages	62
Troubleshooting by LCD Message.....	63
Close Door	63
Check Cartridge	64
Trim Tray Out - Message	66
Trim Tray Out - No Message.....	66
Trim Tray Full	67
Troubleshooting by Error Code.....	68
E423: Unexpected Cut	68
E451: Check Cartridge	68
Fault Codes	69
FAULT: PAPER AT CUTTER.....	69
FAULT: NO FILM AT CUTTER	69
FAULT: LAMINATOR DRAWER OUT	69
FAULT: NO SUPPLY	70
FAULT: TRIM PURGE BLOCKED	70
Power Faults.....	71
No AC Power.....	71
No DC Power	73
User Interface is Dark.....	75
Paper Jams.....	76
Checking for Obstructions	76
Cutter Jams	78

Clutch.....	80
Jam Codes.....	81
J1XX Jams	82
J2XX Jams	83
J3XX Jams	84
J4XX Jams	85
J408: Pressure Roller Jam	85
J422: Film Timeout at Cutter	85
J423: No Film at Cutter	86
J424:Unexpected Trail Edge	86
J5xx Jams	87
J514: No Sheet at Exit.....	87
Jam: Cutter Knife Down	88
Resetting the Film Cartridge.....	89
Sensor Checks	91
Sensor Cables	93
Sensors S1 to S5, S25 to S27.....	94
Sensor 1B - Cutter.....	96
Sensors S6 to S10	97
Sensor S11 to S15	98
Sensor S28 Align Home Sensor.....	99
Sensor S29 Trim Tray	100
Solenoid Checks.....	101
Solenoid SOL1, SOL8	101
Solenoid SOL6	101
Solenoids SOL2 - SOL3	102
Alternate solenoid inspection method:	102
Stepper Motor Checks	104
AC Motor Check.....	106
Repair Procedures	107
Precautions.....	109
Tools Needed	109
Work Environment	109
Pre-Requisites	110
Rear Cover.....	110
Undock the Laminator	110
Dock the Laminator	111
Cabinet	
Top Cover	112
Front Door.....	113
Bottom Hinge Bracket	113
Panel Open Magnet	114
Door Latch.....	115
Interlock Switch	116

Upstream Rear Side Cover.....	117
Left Side Cover	117
Downstream Rear Side Cover	118
LCD Display	119
Casters	120
Docking Brackets.....	120
Exhaust Fan.....	121
Paper Path	
Lower Entrance Panel	123
Lower Exit Panel.....	124
Inner Entrance Panel	125
Entrance Idler Panel	126
Entrance Drive Panel.....	128
Exit Idler Panel.....	129
Drive Exit Panel	131
Hinged Exit Panel	133
Upper Bypass Panel	134
Lower Bypass Panel	135
Bypass Diverter.....	136
Panel Close Magnet	137
Idler Roller	138
Idler Panel Mount Bracket.....	139
Flange Ball Bearing	140
Snap-in Bearing	141
Bearing Housing	142
Drive Idler Roller	143
Timing Pulley	143
Timing Belts	144
132T Timing Belt.....	144
166T Timing Belt	145
539T Timing Belt	145
197T Timing Belt.....	146
162T Timing Belt	146
Drive Roller Assembly.....	147
Stepper and Mount Assembly.....	149
Paper Path Sensors.....	150
Sensors: S1, S25, S26 and S27.....	151
Sensors: S1B, S22 and S24.....	151
Sensors: S2, S3, S4, S5.....	153
Sensor S28.....	154
Sensors 6 through 10	155
Sensors 11 through 15	156
M1-7, M9 Motor Driver (Stepper Board)	157
M8 Motor Driver (Stepper Board).....	158

Solenoids	159
Diverter (SOL1 and SOL8)	160
Entrance Idler (SOL2 and SOL3)	161
Anti-Static Brush	162
Cutter Module	
Motor	163
Belt	163
Clutch	164
Blade	166
Cutter Shaft Ball Bearing	169
Cutter Encoder	170
Trim Tray	
Trim Tray Home Switch	172
Trim Level Emitter	173
Trim Level Receiver	173
Steering Module	
Alignment Module	174
Laminator Alignment Stepper Motor, Pulley and Bracket	176
Alignment Carriage Sub-Assy	177
Steering Stepper Motor	180
Steering Motor Belt (65 Groove)	182
Steering Drive Roller Shaft	183
Steering Idler Panel Weldment	184
Steering Idler Roller Assembly	185
Steering Idler Roller Bearing	187
Steering Drive Panel Weldment	188
Laminator Module	
M8 Motor Driver	189
Cartridge Rail Plate	192
Rollers	193
Lower	193
Pressure	194
Locking Mechanism	195
Handle	196
Clamps	197
Alignment Sensor Bracket	199
Electronics & Controls Repair Procedures	
24V Power Supply	201
AC Filter	202
Main Control Board	203
Communication Board	204
Chip Reader	204
Bracket	205

Breakout Board	205
Adjustments	207
Precautions	208
Pre-Requisites	208
Rear Cover	208
Removal	208
Installation	208
Tools Needed	208
Door Latch	209
Solenoids	210
Diverter Solenoid (SOL1)	210
Trim Diverter Solenoid (SOL 8)	211
Cartridge	212
Stop Magnet	212
Cartridge Foot	213
Stop Bracket	213
Rail Height	215
Paper Path	216
Magnets	216
Pressure Roller Idler	217
Timing Belts	218
Steering Sub-Assembly	218
539T Timing Belt	218
166T Timing Belt	219
132T Timing Belt	220
197T Timing Belt	221
162T Timing Belt	221
Steering Motor Belt	222
Idler Panel Magnetic Latches	223
Drive Panel	224
Entrance Drive Panel	224
Exit Drive Panel	225
Lower Bypass Panel	227
Cutter Module	228
Motor Belt Tension	228
Clutch Indexing	229
Pivot	230
Connecting Rod Length	231
Connecting Rod Spring	233
Lamination Drawer	235
Alignment Pin	235
Drawer Switch	236
Cut Stick	236

Locking Mechanism Springs	237
Drawer Latch	238
Sensors.....	239
S1B - Cutter.....	239
Parts List	240
Cable Part Number Index	261
Wiring	263

Safety

Read all safety information in this manual before performing any maintenance or repairs on this unit.

Cautions, Warnings, and Note statements appear before the steps to which they apply. These statements should be read before continuing to the next step in a procedure.



CAUTION: A Caution statement indicates an operating or maintenance procedure, practice, or condition that, if not strictly observed, could result in damage to, or destruction of, equipment.



WARNING: A Warning statement indicates an operating or maintenance procedure, practice, or condition that, if not strictly observed, could result in personal injury or loss of life.

NOTE: A Note statement indicates an operating or maintenance problem, practice, or condition that is necessary to accomplish a task efficiently.

Safety Devices

The laminator has a door interlock to prevent personal injury when operating the machine.

When you open the front door, a safety interlock device automatically disables the drive motors until you close the Front Door.

When the front door is open, the UI displays the “CLOSE DOOR” message on the top line of the interface.

When you close the front door, the UI displays the “READY” message on the top line of the interface.



CAUTION: Certain components in the laminator are susceptible to damage from electrostatic discharge. Observe all ESD procedures to avoid component damage.

Operational Safety



CAUTION: Do not operate the laminator without the interlocks engaged.

Use care when a procedure in this manual instructs you to “insert an interlock cheater into the laminator door interlock switch SW1,” in order to test the operation of a component.



WARNING: Moving Parts, keep hands clear of nips and the belts when the Interlock Cheater is inserted.



DANGER: HIGH VOLTAGE

This safety message means you might get seriously hurt or killed if you open the product and expose yourself to hazardous voltage. NEVER remove the screwed on covers. ALWAYS refer service requirements to qualified service personal.

Important Safeguards

Use the laminator only for its intended purpose of laminating paper and covers and according to the indicated specifications.



WARNING: The printer ON/OFF switch does not cut off power from the laminator. Always disconnect the electrical power cord.

The laminator must be connected to a supply voltage corresponding to the electrical rating of the machine operation instructions (also listed on the serial number label).

The grounding plug is a safety feature and will only fit into the proper grounding-type power outlet. If you are unable to insert the plug into an outlet, contact a qualified electrician to have a suitable outlet installed.

Do not alter the plug on the end of the cordset (if provided) of the laminator. It is provided for your safety.

Unplug the laminator before moving the machine or whenever the machine is not in use for an extended period of time.

Do not operate the laminator if the machine has a damaged power supply cord or plug. Do not operate the machine after any malfunction. Do not operate the machine in case of liquid spills or if the machine has been damaged in any other way.

Do not overload electrical outlets beyond their capacity. To do so may result in fire or electrical shock.

Do not open any panels other than those indicated by this manual.

Pay particular attention to the WARNINGS and CAUTIONS listed in this and the Operator Manual.

Introduction

Click on the [blue](#) links, shown below, to be taken to the relevant section.

Glossary of Acronyms	4
Specifications	5
Media Input from Printer	5
Serial Number	5
Supplies	5
User Interface	6
Home	6
Settings	7
User Functions	8
Cycle Cutter	8
Trim Film and Eject	8
Film Proof Test	8
Center Alignment	8
Margin	8
Skew	8
First Sheet	9
Language & Units	9
Cut Stick	9
Info	9
Laminator Cycles	9
Firmware	9
Service Menu	10
User Functions	11
Cutter Blade	11
Sensors	11
Motors	11
Solenoids	12
Function Tests	12
Files	13
Options 1	13
Options 2	13
Alignment Offsets	13
Printers	13
Firmware Update / Save Logs	14
Max Bypass	15

Glossary of Acronyms

Acronyms you may encounter in this manual include:

Acronym	Definition
Assy	Assembly
CBL	Cable
DRV	Motor Driver (Stepper Board)
F	Fuse
GND	Ground
J	Connector
M	Motor
N	Nip Roller
P	Plug
PSU	Power Supply
S	Sensor
SOL	Solenoid
SW	Switch
UI	User Interface

Specifications

Media Input from Printer

Registration at pick up (includes skew)	Sheet lamination	±10mm (.39")
Maximum skew	Sheet lamination	±25 millirads (1.43 degree)
Feed speed	Set to match engine (maximum 1300mm/s)	
Speed variance at pick up	±2%	
Productivity	See Appendix A	
Curl	Maximum of 10mm from mid face to edge	



Paper weight	Plain	75gsm – 300gsm (20lb bond – 110lb cover)
	Coated	118gsm – 300 gsm (32lb bond – 110 lb cover)
Paper sizes	Standard	A4, A3, SRA4, SRA3, LTR, 9x12, 11x17, 12x18
Sheet size tolerance		±0.75mm

Serial Number

The serial number is located inside the front door on the front frame just below the bypass section.

Supplies

- Laminator Film Frame Refill
- Super Lube
- Cut Sticks

User Interface

Home



BACK - Returns you to the previous screen without making changes.



SAVE - Saves changes made in settings.

Status Messages

Interactive Buttons

The UI displays status messages and fault codes in two rows of text.

- The top row displays the status of the Laminator (Ready, Close Door).
- The bottom row displays the options selected on the UI.

Settings

Click on any [blue text](#) to be taken to additional information about the setting.

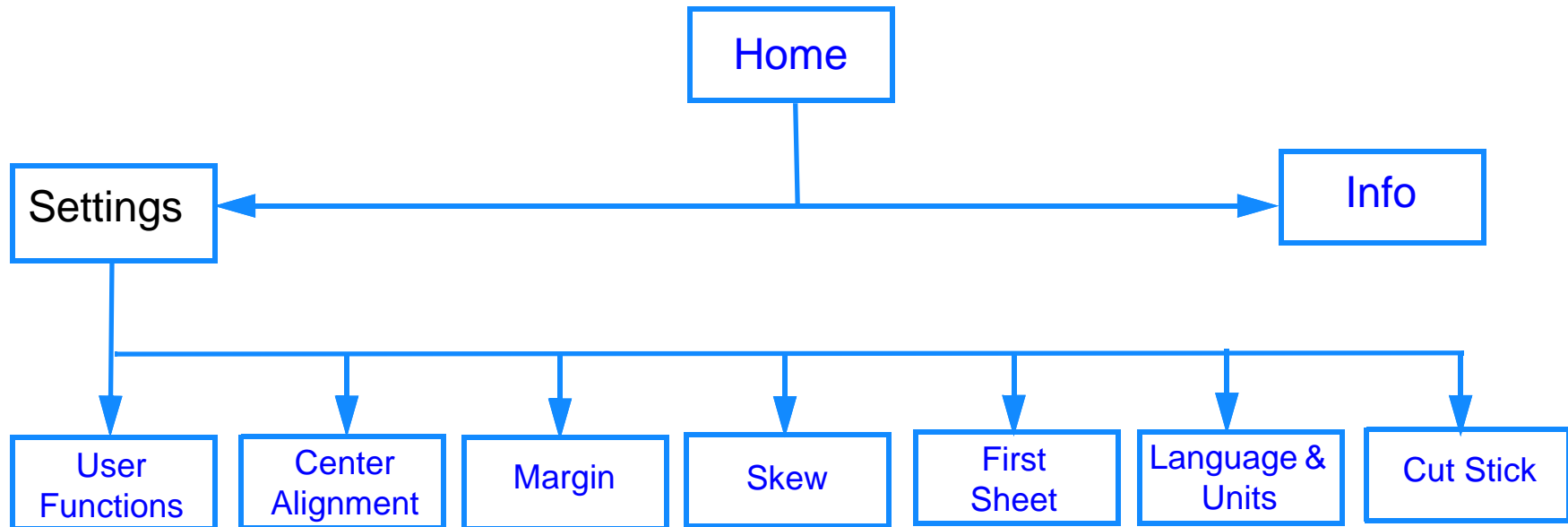

User Functions

User functions will change depending on what type of lamination material is currently installed.

Cycle Cutter

Use this to manually cycle the cutter. This can be used if a sheet has partially cut and needs to be fully cut to remove the drawer. The door needs to be closed to run this function.

Trim Film and Eject

This cycle will feed a length of laminated film 120mm into the trim tray. This is the same cycle that occurs before the first sheet of each job. The door needs to be closed to run this function.

Film Proof Test

This cycle will feed a length of laminated film around 200mm into the trim tray. The door needs to be closed to run this function. This cycle can be used to clear wrinkles after resealing the film, before running a new refill or to clear a partially laminated sheet.

Center Alignment

This setting controls the front/rear paper position relative to the film. Use the +/- buttons to shift the current paper position so that the sealed film edge is 4mm on each side.

1. On the Home screen, tap **Settings**.
2. Tap **Alignment**.
3. Select the desired adjustment.
4. Use the **+/- buttons** to change the offset by + or - 0.2mm.
The maximum alignment change is + or - 2.0 mm
5. Press the **CHECK MARK** button to enter the new alignment value.
6. Click YES to save the value permanently or NO to save only until the next time the machine is turned on.

Margin

The "A" and "B" boxes will start off filled with a hyphen (-). Measure the dimensions of "A" and "B" on an out-putted sheet and enter the values into the boxes and select the check mark button.

The machine will automatically calculate the Gap (AT) and Cut (AC) adjustment values needed based on the margin measurements and fill those boxes. Small edits to the Gap and Cut values can be made by clicking on the lower two boxes and using the +/- buttons.

Skew

1. On the Home screen, tap **Settings**.
2. Scroll to the third page and tap **Enter Service Mode**.

3. Type in password **422** and press **Enter**.
4. Select **Skew Offsets**.
5. Change your desired option to straighten the paper inside the laminate.

First Sheet

The margin screen controls the size of the film border on the lead and trail edges on all sheets except the first. To control the first sheet lead edge, use the adjust buttons +/- to increase/decrease the gap, as desired.

Language & Units

Select the language, English, Deutsch, Espanol, Francais, or Italiano for the UI. Set the units displayed on the UI by choosing MM for millimeters or IN for inches.

1. On the Home screen, tap **Settings**.
2. Scroll to find **Language & Units** and tap it.
3. Make your selection for the language and/or the units and then tap the **CHECKMARK** to set the change.
4. Click YES to save the selection permanently or NO to save only until the next time the machine is turned on.

Cut Stick

The cut stick screen displays the current amount of cuts on the cut stick groove out of the 1,000 total. Be sure to use the cut stick cycles reset to change the count back to zero if the cut stick is flipped to a new surface or replaced.

Info

To find information about the following:

1. On the Home screen, tap **Info**.
2. Tap the page pertaining to the features below.
3. Tap the back button to return to the Info screen.
4. Tap the back button again to return to the Home screen.

Laminator Cycles

Lists the number of lamination cycles completed by the film cartridge that is presently installed in the machine.

Firmware

Identifies the version of firmware installed.

Service Menu

Click on any [blue text](#) to be taken to additional information about the menu option.

This menu allows you to complete service adjustments on the system. This menu is not meant to be accessible by the user.

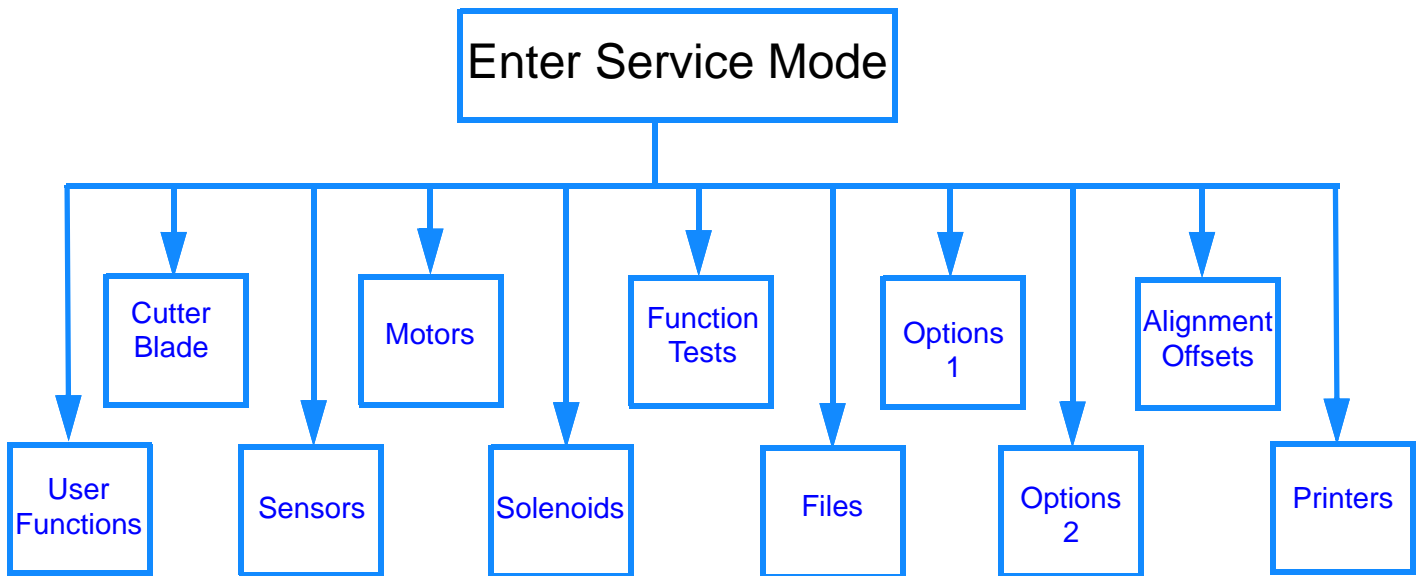

User Functions

User functions are described in the user manual.

Cutter Blade

The blade cycles show the total cuts that the current blade has made during its lifetime. When servicing the machine and installing a new blade, make sure to use the Blade Cycles Reset button to reset the count to zero.

Sensors

A sensor can fail in two modes:

- **High state:** Machine thinks there is no sheet even when a sheet is present. In this mode, the LCD will always show “0” for that sensor, and will not go to “1” when a sheet is present.
- **Low state:** The converse of the above. “PAPER JAM” message will be seen on LCD.

It is unlikely for a sensor to fail in a Low state, therefore a bad sensor will most likely not give a “PAPER JAM” message.

When there is a paper jam, it is most likely because there is a sheet of paper or paper dust over the sensor.

View the state of each of the sensors.

- 0 - sensor is open.
 - 1 - sensor is covered.
1. On the Home screen tap **Settings**.
 2. Scroll to the third page and tap **Enter Service Mode**.
 3. Type in password **422** and press **Enter**.
 4. Tap the **Sensors** button.
 5. Cover each sensor to check if the sensor status changes from 0 to 1.

Motors

Use this to test each of the motors in the machine.

IMPORTANT: The door needs to be closed when doing this procedure.

1. On the Home screen, tap **Settings**.
2. Scroll to the third page and tap **Enter Service Mode**.
3. Type in password **422** and press **Enter**.
4. You will hear the motors engage.
5. Press the motor button a second time to stop it.
6. Repeat as needed to check the other Stepper Motors.

Solenoids

Test the operation of each of the solenoids in the machine.

IMPORTANT: The door needs to be closed or the interlock cheater inserted.

1. On the Home screen, tap **Settings**.
2. Scroll to the third page and tap **Enter Service Mode**.
3. Type in password **422** and press **Enter**.
4. Tap **Solenoids**.
5. Press the specific solenoid button of the one you want to test.
The selected solenoid will turn on temporarily.
6. Press the button a second time to disengage the solenoid.

IMPORTANT: If solenoid is left on for an extended period of time, it will turn off automatically to prevent over-heating.

7. Repeat as needed to check the other solenoids.

If a Solenoid does not operate run through the cleaning procedures [Solenoid on page 30](#), [Diverter Solenoid \(SOL1\) Assembly on page 37](#) and [Trim Diverter Solenoid \(SOL8\) on page 39](#).

Function Tests

Use this function to jog a short piece of film (120mm) without cutting it at the end. This function is used to test that the film is moving properly through the pressure rollers without the cutter.

1. On the Home screen, tap **Settings**.
2. Scroll to the third page and tap **Enter Service Mode**.
3. Type in password **422** and press **Enter**.
4. Select the desired test to run.

Press **User Functions** to:

Cycle Cutter starts the cutter motor, waits for 2 seconds, then triggers the cutter for 1 cycle.

Press **Functions Tests** to:

Aligner Test moves the home aligner clockwise 10mm, back to home, counter-clockwise 10mm, then back to home; repeating the cycle 5 times. After the test is complete it stops automatically.

Fan turns the exhaust fan on and off.

Files

The Update Main/Comm buttons will update the machine firmware to the latest version when a USB with the proper .BIN file is inserted into the back of the machine.

The Save Log button will save the latest job information to a USB inserted into the back of the machine. Use this button if directed to by GBC to help troubleshoot issues in the field.

Additional information can be found in [Firmware Update / Save Logs on page 14](#).

Options 1

Paper size can be switched between ANSI and ISO, depending on the preferred paper standard. For example, A4 would be ISO and LTR paper would be ANSI. If this is not set correctly, the machine will not be able to recognize the paper size that is being sent from the printer.

Leave the Run Mode in Auto Run unless directed by GBC to change to Auto Cycle for troubleshooting. Auto Cycle allows certain mechanisms to cycle repeatedly. The machine will not process jobs from the printer properly unless it is set to Auto Run mode.

Options 2

Ignore Cart Errors can be toggled to the on position to allow the machine to operate even when the cartridge chip is not properly connected. This will override the errors and allow jobs to be sent from the printer. Caution should be taken when running this mode, because the machine will not know to stop if the film remaining reaches zero, and this could cause a jam.

Auto-Jam recovery can be toggled on/off. This setting is normally "on" to allow the machine clear jams easier. The setting can be toggled to "off" for troubleshooting.

Max Bypass controls the largest sheet length that is allowed to run through the bypass path of the machine. This setting does not have any effect on lamination mode. See additional information in [Max Bypass on page 15](#).

Alignment Offsets

This panel is used during machine setup at the factory. Do not attempt to use this in the field.

Printers

Select the correct attachment printer in this section to ensure AdvancedLam Pro can match the bypass speed of the sheet as it enters the machine.

Firmware Update / Save Logs

Firmware Update:

NOTE: Save the firmware file you want to upload to the USB flash drive provided. The firmware file will end in .BIN. Old firmware files can be saved in a new folder if needed.

IMPORTANT: Only one Main and one Comm file should be present in the USB flash drive.

1. Remove the (2) M4 screws and the USB port cover.
2. Open the front door and leave the door open until the procedure is complete.
3. On the Home screen, tap **Settings**.
4. Scroll to the third page and tap **Enter Service Mode**.
5. Type in password **422** and press **Enter**.
6. Use the scroll bar to navigate to the second page of the menu and tap the **Files** button.
7. Insert the USB drive with the firmware version you want to upload onto the machine.
8. Click on the option to be upgraded. If upgrading both, it is recommended to upgrade Main first.
 - Main - updates the control board and the Main firmware.
 - Comm - updates the communication board. The screen will turn black temporarily while COMM is updating.
9. Install the cover for the USB port and tighten the (2) screws.
10. Close the door.
11. Switch off the machine. Wait 10 seconds and then switch the machine back on again.
12. Press the **INFO** button to verify the new firmware revision is displayed on the Info screen.

Save Logs:

1. Remove (2) M4 screws and the USB port cover.
2. Insert a USB drive in the machine, then select Log on the UI.
3. On the Home screen, tap **Settings**.
4. Scroll to the third page and tap **Enter Service Mode**.
5. Type in password **422** and press **Enter**.
6. Use the scroll bar to navigate to the second page of the menu and tap on the **FIRMWARE/LOG** button.
7. Tap **Save Logs**.

Information for the last 50 cut sheets will be downloaded to the USB drive.

Debug data for last 50 sheets.

- Sheet size measured i.e S,M,L,LG or XL
- Skew sensors
- First deskew steps
- Alignment sensor used
- Second deskew steps.
- Align fail safe stop (if occurred)

Sensor timings for last 10 sheets.

- Lamination mode, time from LE S1 to LE S8
- Lamination mode, time from LE S8 to LE at S25

Other data

- Lamination cycle count
- Bypass cycle count
- Individual die type counts
- Record the last 20 Jam codes in a column format
- Logs of E423 Unexpected Cuts

Max Bypass

1. On the Home screen, tap **Settings**.
2. Scroll to the third page and tap **Enter Service Mode**.
3. Type in password **422** and press **Enter**.
4. Select **Max Bypass**.
5. Use the +/- buttons to set the maximum sheet length that will be bypassed through the laminator.
NOTE: Setting the maximum sheet length to high allows large banner sheets to be bypassed by the laminator. A high value for max bypass will cause paper jams to be detected more slowly, which could lead to more wasted paper.
6. Press the **CHECK MARK** button to enter the new value.
7. Click YES to save the value permanently or NO to save only until the next time the machine is turned on.

Service Call Procedures

At each service call run through the procedures described in this chapter. Doing so may fix the issue for which the service call was initiated. Click on the [blue](#) links, shown below, to be taken to the relevant section or procedure.

NOTE: Cycles refers to lamination cycles.

Tools Needed	17
Preventive Maintenance	17
Schedule	17
Cleaning	19
Exterior	19
Interior	19
Base	19
Trim Tray	20
Idle Roller	20
Steering Idle Roller and Springs	21
Drive Rollers	22
Steering Drive Rollers	23
Pressure Roller	24
Optical Sensor	26
Exit Panel (Inner)	27
Bypass Paper Path	28
Lamination Paper Path	29
Solenoid	30
Alignment Carriage Rails	32
Cutter Clutch	33
Cutter Out-feed Baffle	35
Cutter Blade	36
Diverter Solenoid (SOL1) Assembly	37
Trim Diverter	38
Trim Diverter Solenoid (SOL8)	39
Chip Reader	40
Inspection	41
Door Latch	41
Idle Roller and Idle Springs	42
Panel Latch	43
Paper Path Timing Belt	44
Cutter Blade	45
Cut Stick	46
Cartridge Rail	47
Cartridge Tray	48
Cartridge Frame	49

Tools Needed

Recommended tools for servicing the machine.

Standard Tools (metric)

- 7mm Nut Driver
- 5.5mm Nut Driver
- 7mm Open End Wrench
- 5.5mm Open End Wrench
- Needle Nose Pliers
- Phillips Screwdriver
- Flathead Screwdriver
- Wire Cutters
- Metric Allen Key Set (1.5mm, 2mm, 2.5mm, 3mm, 4mm, 5mm)
- Super Lube

Preventive Maintenance

Perform any necessary procedures shown on the schedule. To view the period for each, follow these steps:

1. On the display, click Settings.
2. Enter your service code.
3. View the period for each area of the unit and compare with the schedule.

Schedule

Customer Maintenance

Cutting Stick	1,000 cycles, rotate and replace 4 times = 4,000 cuts
Lamination supply	Replace when empty

Periodic Maintenance

Area / Unit	Period	Measures
Cutter motor belt	1,000K cycles	Inspect

Periodic Maintenance

Area / Unit	Period	Measures
Alignment stepper belt	1,000K cycles	Inspect
Steering carriage belt	1,000K cycles	Inspect
Steering rollers	1,000K cycles	Inspect and clean
Cutter clutch	1,000K cycles	Clean
High speed sensors	500K	Clean with air and anti-static wipe
Drive and Idler rollers	1,000K cycles	Inspect and clean with alcohol
Solenoid module	1,000K cycles	Inspect
Paper path sensors	500K	Clean with air
Idler panel closing magnet latches	1,000K cycles	Inspect
Corner panel latches	1,000K cycles	Inspect
Paper path drive timing belts	1,000K cycles	Inspect and adjust if necessary
Diverter solenoid assemblies	1,000K cycles	Inspect
Supply recognition board pins	500K	Clean, replace if necessary
Pressure roller belt	500K	Inspect, replace if necessary

Replacement of Consumable Parts

Area / Unit	No. of pcs.	Minimum Expected Life
Idler solenoid module	2	5M cycles
Cutter blade	1	250,000 cycles
Lamination pressure rollers	2	10,500 metres of film (approx. 160 film refills) (1/year)
Anti-static brush	3	500K cycles
Cutter clutch	1	250K cycles
Cartridge frame	multiple	3,000 cycles

Cleaning

This section lists all of the different areas to clean.



WARNING: Disconnect the laminator from its power source before cleaning. Failure to observe this warning could result in death or serious injury.

Exterior

Clean the exterior covers with a lint-free cloth moistened with mild detergent and warm water.

IMPORTANT: Do not use chemical cleaners or solvents as these may have a harmful effect. Use detergent sparingly to avoid contact with electrical components.

Interior



WARNING: Make sure you disconnect the machine from its power source before cleaning. Failure to observe this warning could result in death or serious injury.

1. Remove the covers and clean out paper dust and trims.

Paper dust can accumulate throughout the laminator including around the motor and other electrical components.

Use a vacuum cleaner if possible. A small paintbrush can also be used but **extreme care should be used around electrical components.**

2. Clean non-electrical components with isopropyl alcohol, an approved cleaner, or a lint-free cloth moistened with mild detergent and warm water.
3. Clean the rollers with isopropyl alcohol.

Base

Trims and paper dust fall to the bottom of the laminator. Clean with a vacuum cleaner every service call.

Educate the customer on how to do this between technician visits.

Trim Tray

Do this on every service call. Remove the trim tray by lifting up and pulling out. Empty the tray, then vacuum out any remaining dust.



Idler Roller

Inspect and clean the idler rollers in these assemblies every 50K cycles.

- Entrance Idler Panel.
 - Acceleration Roller Idler Assy.
 - Exit Idler Panel.
 - Bypass Idler Assembly
1. Follow instructions [Idler Roller on page 138](#) to remove.
 2. Clean the Idler Rollers with a lint-free cloth and isopropyl alcohol.
 3. Inspect rollers for wear patterns or grooves.
The roller surface should be smooth.
 4. Ensure the rollers turn freely on the shaft and that the idler roller shaft “floats” freely in the bushing forks.
 5. See [Idler Roller on page 138](#) to install.

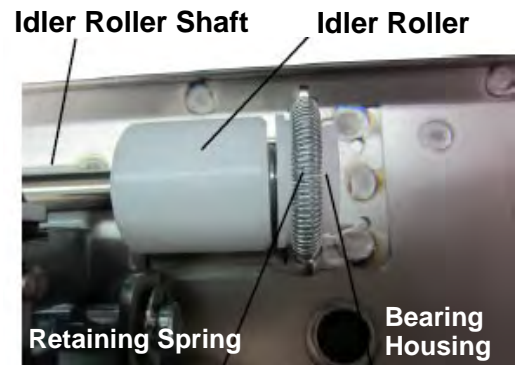

Steering Idler Roller and Springs

Inspect and clean Steering Idler Rollers and Springs N5 and N6 every 20K cycles.

1. Pull out the lamination drawer and remove the (2) 5.5mm nuts for the cover.



2. Clean the steering idler rollers with a lint-free cloth and isopropyl alcohol.

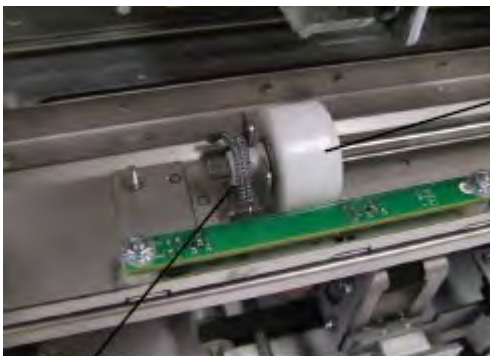
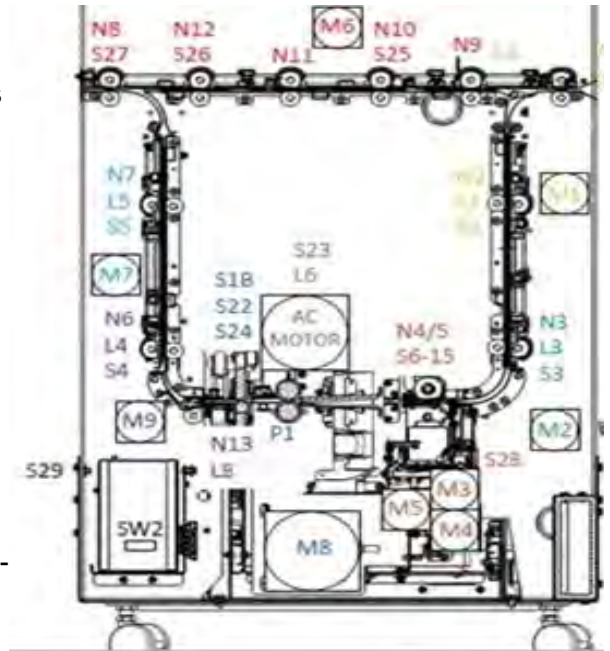

Steering Idler Roller

Spring

3. Confirm that the roller surfaces are free of debris, toner deposits, wear, unevenness, and dents.
4. Inspect the Steering Idler Springs.
The springs should be hooked securely and should be wrapped around the bushing.
5. Follow instructions to clean the [Drive Rollers on page 22](#).

Drive Rollers

There are 24 rollers on 11 shafts.

1. Remove the rear cover.
2. Open the front door and pull out the lamination drawer.
3. Go to back of machine and clean rollers on the left and right sides.



4. Return to the front, push lamination drawer in.
5. Lift up and pull down the bypass panel to reach and clean the rollers.

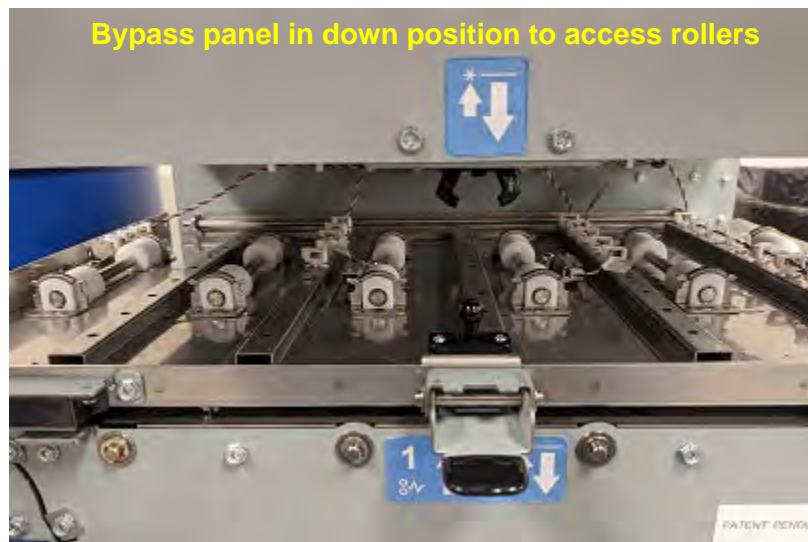

Steering Drive Rollers

Inspect and clean the steering drive rollers every 20K cycles.

Some rollers are not easily accessible. Those that are should be inspected and cleaned when the idler rollers are removed.

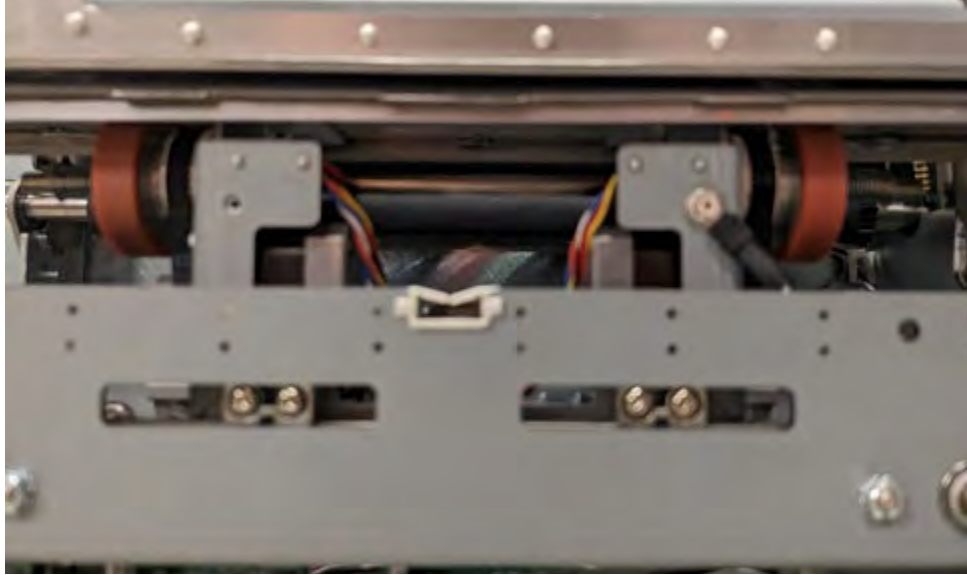

1. Open the front door and pull out the lamination drawer.
2. Clean all steering drive rollers N1 – N16 with a clean cloth and isopropyl alcohol.
The rollers should be free of toner deposits, wear marks, scuff marks, dents, etc.

Pressure Roller

Inspect and clean the pressure roller every 12K cycles.

1. Open the front door and pull out the lamination drawer.
2. Remove the [Locking Mechanism on page 195](#).
3. Remove the infeed, cutter, and upper assembly baffle.

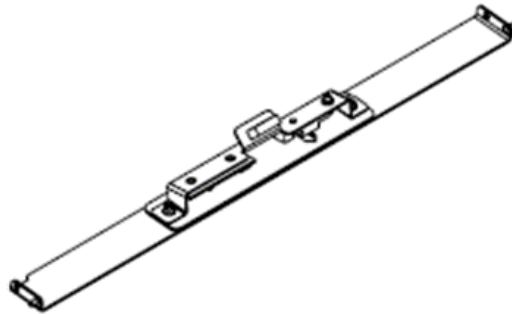

4. Dampen a lint-free cloth with isopropyl alcohol and wipe roller until all adhesive build-up is removed.

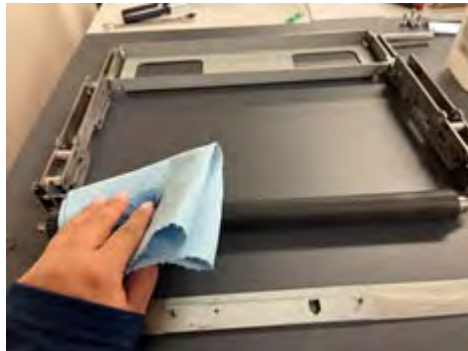

5. Inspect the gears on the locking mechanism for discoloration, metal shavings, damaged or missing teeth. If damaged, replace the assembly by referring to [Rollers on page 193](#).



6. Clean the lower pressure roller as you rotate it by hand.

NOTE: The lower pressure roller is more easily accessible with the locking mechanism removed.

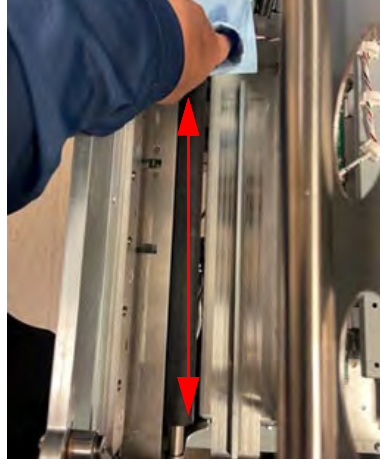

Optical Sensor

Inspect and clean every 50K cycles.

For paper path sensors S1–S5, S24–S27 use canned air or a clean cloth and isopropyl alcohol to remove the debris off each sensor eye.

For edge detection sensors S6-S15 use the folded corner of an anti-static, pre-moistened lens cleaning wipe (non- alcohol based) for cleaning the LED until the dust/debris is completely removed. Use canned air to remove dust/debris from the slot between the 2 LEDs.

NOTE: Any group of sensors, for example S6 through S10, will be on one sensor array board while S11 through S15 will be on a different board.

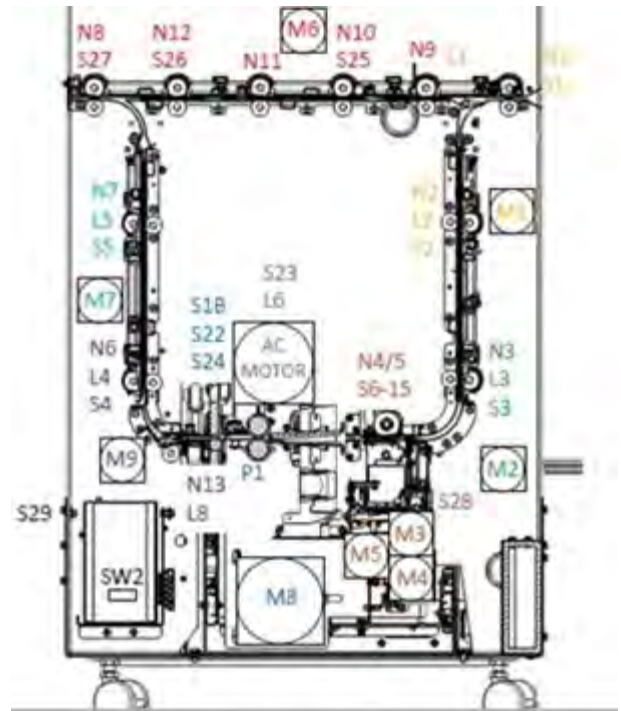

Exit Panel (Inner)

1. Open the front door.
2. Use a 7mm driver to remove the (3) screws.



3. Loosen, but do not remove, the (3) screws shown below.

Loosening the bypass panel will make it easier to remove and reinstall the inner panel.

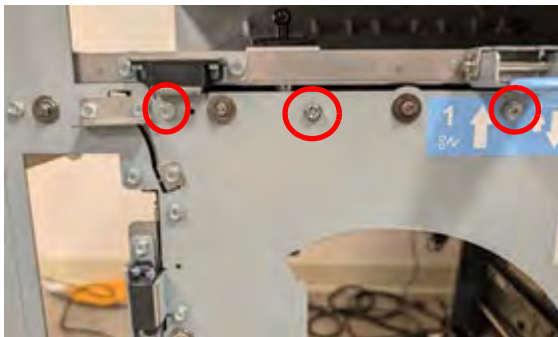

4. Carefully pull the panel out making sure to avoid letting the left side scrape against the frame, which could damage the plastic anti-adhesive coating.
5. Use a lint-free cloth and isopropyl alcohol to remove any built-up adhesive on the plastic coated surface.
6. Inspect the plastic coating for cuts or tears and replace the panel if damage is found.
7. Follow the procedure to clean the [Bypass Paper Path on page 28](#).
8. Install the panel by inserting the two tabs into the slots in the rear of the machine.
9. Insert and tighten the (3) screws.
10. Tighten the (3) bypass panel screws.
11. Close the front door and connect the power cord.



Bypass Paper Path

Inspect and clean the bypass paper path every 20K cycles.

1. Inspect the underside of the bypass panel, on the exit side, and nip roller 8 for adhesive build-up and clean with a lint-free cloth and isopropyl alcohol.
2. Inspect the bypass panel, rollers, and entrance guide for wear, damage, and obstructions.
3. Inspect the rollers for wear patterns or grooves.
4. Clean rollers with a soft, lint-free cloth and isopropyl alcohol.
5. Raise the panel and ensure the latch holds it open.
6. Inspect the path for obstructions and clean as needed.
7. Close the panel and check that it is flat and that paper will pass under it.
8. Ensure the bypass diverter moves freely and returns to the bypass position.



Lamination Paper Path

Inspect and clean the paper path every 20K cycles.

1. Inspect the entire paper path through the laminator, looking for wear, damage, and obstructions.
2. Inspect the rollers for wear patterns or grooves.
3. Push down to open the entrance idler panel, acceleration panel, and exit idler panel and make sure there are no obstructions and that they hold the panel tightly in place.



NOTE: If the latch is bent or damaged, replace the [Entrance Idler Panel on page 126](#), [Entrance Drive Panel on page 128](#) or the [Exit Idler Panel on page 129](#).

4. Clean as needed.
5. Pull the lamination drawer out.
6. Remove the [Locking Mechanism on page 195](#).
7. Use isopropyl alcohol to clean the baffle, located between the bottom pressure roller and blade, until all adhesive buildup is removed.
8. Follow the steps in [Lower Exit Panel on page 124](#) to remove the panel.
9. Inspect the black film for cuts, tears and adhesive build up.
10. If the film is damaged, replace the panel. Clean any adhesive build up using Isopropyl alcohol and a lint-free cloth.
11. Reinstall the panel.

Solenoid



WARNING: Moving Parts, keep hands clear of nips and belts when the interlock cheater is inserted.

Clean the solenoids every 100K cycles.

1. Open the front the door and insert an interlock cheater into the door interlock.
2. Activate and deactivate the [Solenoids on page 12](#).

When the solenoid is not activated, the idler roller should be able to rotate freely and in turn will drive the drive roller.

When the solenoid is fully activated, the idler roller should completely lift off and not be able to drive the drive roller.



Not Activated



Fully Activated

NOTE: Disengaging solenoid modules need to be replaced every 5 million cycles.

3. Clean the solenoid and surrounding area with a vacuum cleaner and canned air.



4. Make sure the solenoid is clean and dry.
5. Inspect for obstructions, wear or damaged springs.
6. Ensure the solenoid linkage moves freely by pressing linkage down and releasing.

IMPORTANT: Do not apply lubricants to the solenoid or linkage.

Alignment Carriage Rails

Clean the alignment carriage rails every 20K cycles.

1. Open the front door and pull out the lamination drawer.
2. Use a can of compressed air to remove dust from the alignment carriage rails; moving the carriage back and forth on the rails to clean the entire surface.

Alternately, a lint-free cloth and isopropyl alcohol can be used.

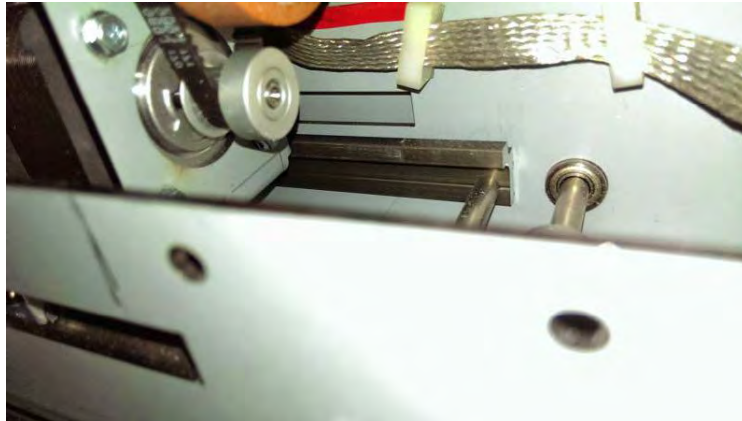

IMPORTANT: Do NOT use any lubricant on the rail.

3. After the rails are fully cleaned, check the motion of the alignment carriage on the rails. It should move when a force less than 2kgf is applied. If there is binding in the rails, replace the [Alignment Carriage Sub-Assy on page 177](#).

Cutter Clutch

Clean the clutch every 100K cycles.

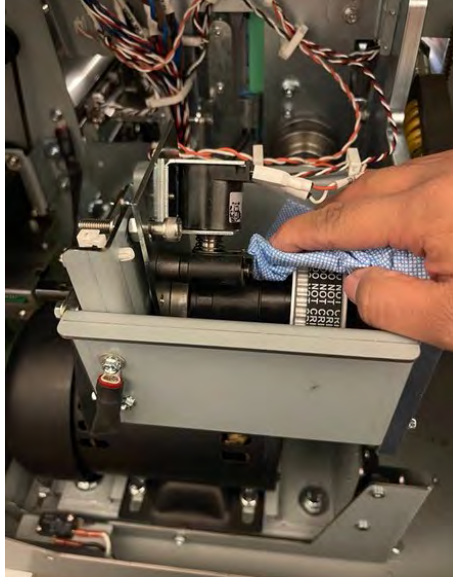

If the cutter module is removed from the machine for servicing other components, do all steps below. Otherwise do all steps except step 9.

1. Disconnect the power cord.
2. Remove the [Rear Cover on page 110](#).
3. Use a lint-free cloth to wipe the collar of the clutch and remove any oil from the surface.
4. Inspect the collar stop and the metal insert pawl for any wear.



5. Check the tightness of the (2) cone point set screws in the clutch.

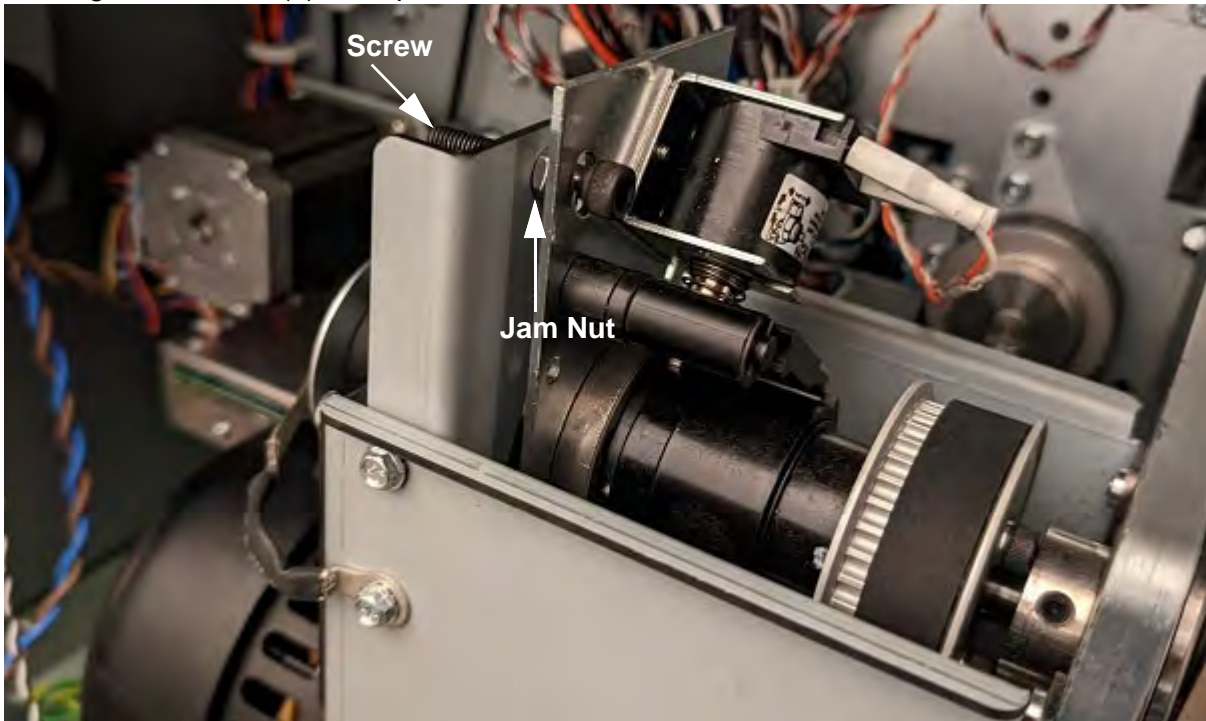

6. Inspect the tightness of the M6 lock nut and M6 socket head cap screw.
7. Check the [Clutch Indexing on page 229](#).
8. Install the [Rear Cover on page 110](#).
9. Connect the power cord.
10. Run the [Function Tests on page 12](#).

Cutter Out-feed Baffle

Clean the out-feed baffle every 12K cycles.



WARNING: Do not perform any cleaning with the power on or electrical power supplied to the machine.

1. Open the front door and pull out the lamination drawer.
2. Remove the screw holding the sensor plate and set aside.



3. Remove the (4) thumbscrews holding the cutter baffle and set aside.

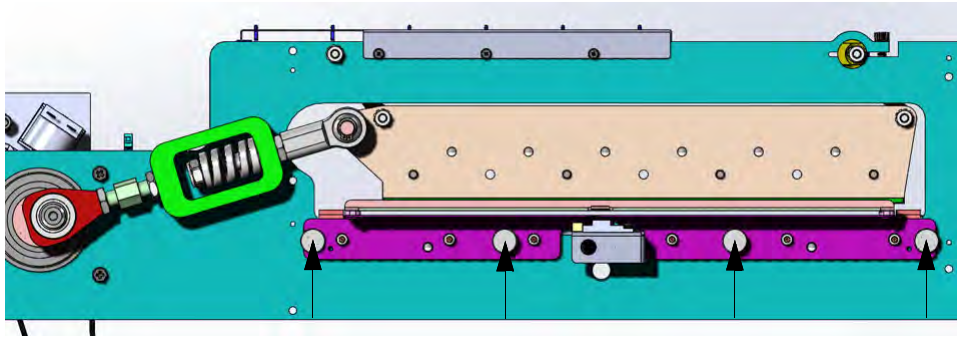

4. Remove the baffle from the cutter module and inspect it for adhesive build-up, especially along the edges. If adhesive is stuck inside the baffle, remove the (4) screws to get to the inside.



5. Remove built-up adhesive using a paper towel soaked in isopropyl alcohol. When you slide your finger across the baffle and can no longer feel stickiness, it is clean.

NOTE: Baffle parts are covered with UHMW tape, which helps reduce friction and adhesive build-up, take care not to damage the tape.

6. Re-assemble the baffle, if needed, by securing the (4) screws and making sure the spacers between the baffle panels and screws are facing the correct direction.
7. Replace the baffle and return the machine to normal operation.
8. Feed laminate through the module by using the Jog Film command in the Service Menu > Function Test. Adhesive build up is visible and can be felt. It will not be visible on the sheet output but can cause jams.

Cutter Blade

1. Perform the inspection for the [Cutter Blade on page 45](#) through step 6.
2. Open the front door and locate the wrench mounted on the front of the lamination drawer.



3. Cut a strip from a scouring pad the same width as the wrench.
4. Dampen the pad with isopropyl alcohol and fold it over the raised end of the tool.
5. Confirm the toggle clamp is in the up position.
6. Place the wrench with the raised end parallel to the blade edge. The raised portion of the tool should slide upwards behind the blade edge.



The pad should be wedged between the tool and the blade. The flat portion of the tool will rest against the foam that is in front of the blade.



CAUTION: Keep fingers clear from blade to avoid injury.

7. Slowly move the tool from left to right across the length of the blade.
If the pad tears or the gathers too much adhesive, use a different part of the pad.
8. Inspect the [Cutter Blade on page 45](#), step 5 bullets and follow the steps in reverse order to replace the parts.
9. Connect the power cord.

Diverter Solenoid (SOL1) Assembly



WARNING: Moving Parts, keep hands clear of nips and belts when the interlock cheater is inserted.

Clean the diverter solenoid assembly every 50K cycles.

1. Disconnect the power cord.
2. Remove the [Rear Cover on page 110](#).
3. Clean the solenoid and surrounding area with a vacuum cleaner and canned air.
4. Make sure the solenoid is clean and dry.
5. Raise the diverter solenoid by hand and release it to confirm it falls freely.
6. Ensure the linkage operates smoothly.

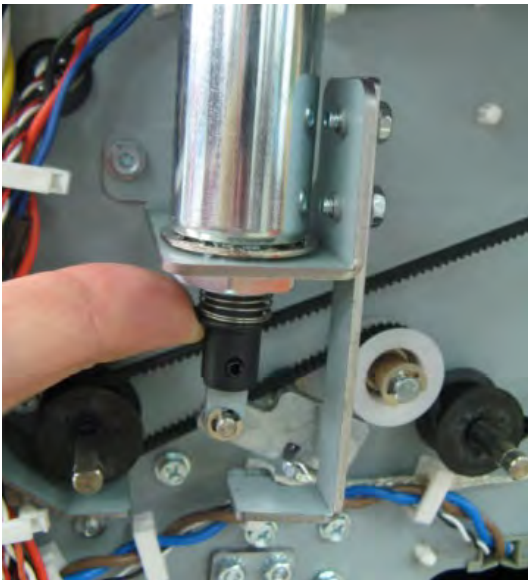

7. Open the front door and insert an interlock cheater into the door interlock switch.
8. Press the power switch to the ON position.
9. Activate and deactivate SOL1 by following [Solenoids on page 12](#).
The diverter gate should rise and fall when SOL1 is cycled.

Trim Diverter

Clean the trim diverter assembly every 50K cycles.

1. Disconnect the power cord.
2. Remove the [Rear Cover on page 110](#).
3. Remove the trim tray.
4. Use a 7mm wrench to remove the (2) screws securing the diverter solenoid to the shaft.

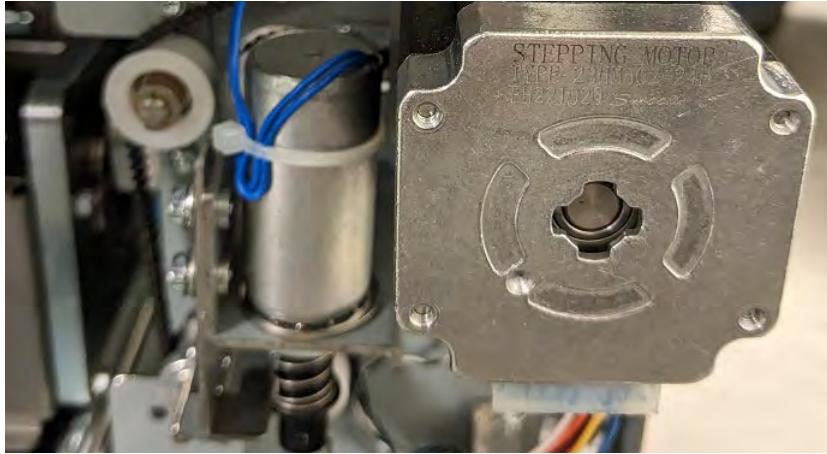

5. Remove the E-ring and plastic washer securing the shaft at the front of the machine and store in a safe location.

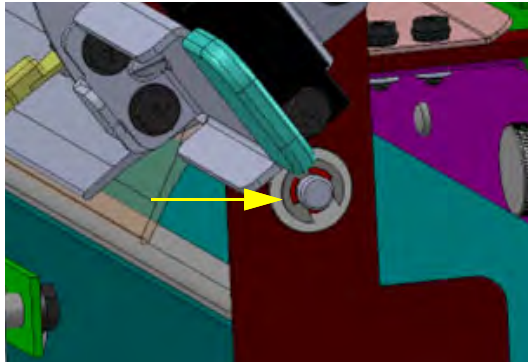

6. Push the diverter shaft towards the rear of the machine until the shaft releases from the front bearing.
7. Drop the shaft down and pull the diverter out through the trim tray opening.
8. Clean the plastic-coated sections of the diverter using isopropyl alcohol and a lint-free cloth.
9. Inspect the plastic for damage and replace the diverter assembly if there are tears or holes.
10. Install the diverter by inserting the shaft through the rear of the bearing and then pulling it through the front.
11. Insert the washer and E-ring.
12. Connect the solenoid bracket to the shaft with the (2) 7mm screws.
13. Perform the adjustment for the [Trim Diverter Solenoid \(SOL 8\) on page 211](#).
14. Install the [Rear Cover on page 110](#).

Trim Diverter Solenoid (SOL8)



WARNING: Moving Parts, keep hands clear of nips and belts when the interlock cheater is inserted.

Clean the trim diverter solenoid assembly every 50K cycles.

1. Disconnect the power cord.
2. Remove the [Rear Cover on page 110](#).
3. Clean the solenoid and surrounding area with a vacuum cleaner and canned air.
4. Make sure the solenoid is clean and dry.
5. Raise the diverter solenoid by hand and release it to confirm it falls freely.
6. Ensure the linkage operates smoothly.

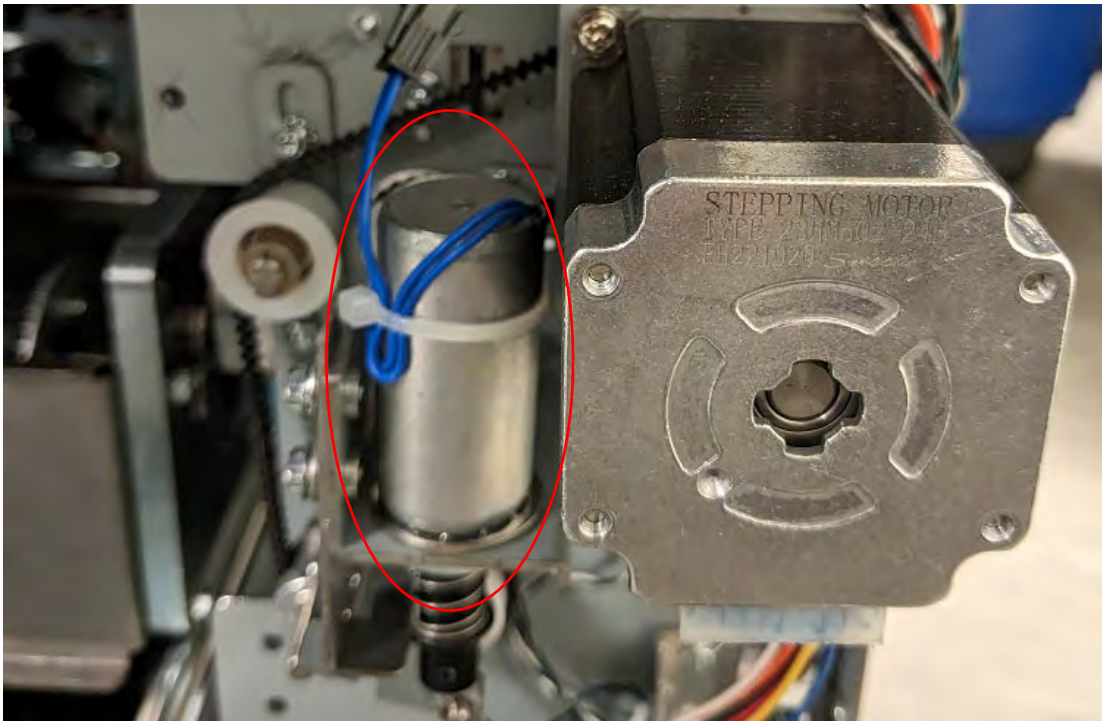

7. Open the front door and insert an interlock cheater into the door interlock switch.
8. Press the power switch to the ON position.
9. Activate and deactivate SOL8 by following [Solenoids on page 12](#).
The diverter gate should rise and fall when SOL8 is cycled.

Chip Reader

Inspect and clean the chip reader pins every 50K cycles.

1. Power off the machine.
2. Open the front door and pull out the laminator drawer.
3. Remove the film cartridge.
4. Locate the chip reader pins.



5. Using a soft, lint-free cloth, gently clean the pins of any debris or dust.
6. Reinsert the film cartridge and power on the machine.
7. Ensure that the film size and film count are correct on the screen.
8. Resume normal operation.

Inspection

Door Latch

Inspect the door latch every 1000K cycles.

The switch tab should press the switch button just so that it is close to bottom.

1. Ensure latch holds door closed.
2. Confirm the switch is activated when the door is closed.
3. Adjust the [Door Latch on page 209](#).

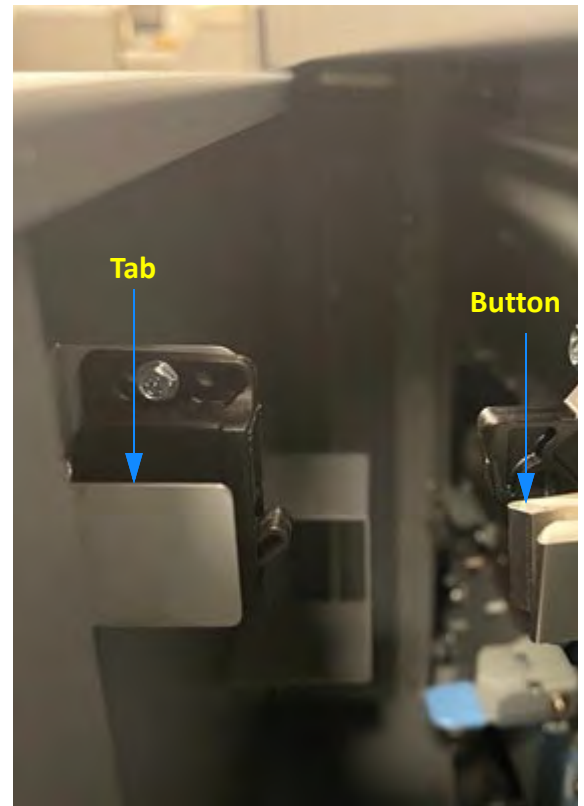

Idler Roller and Idler Springs

Idler rollers press against the drive rollers and move the paper through the bypass or the laminator. Inspect and clean every 100K cycles.

1. For the idler rollers in the following nip rollers, inspect the rollers for wear, debris, toner marks, unevenness, and dents.

N1	N8
N2	N9
N3	N10
N4	N11
N5	N12

2. Inspect (2) springs for each idler roller and make sure they are correctly hooked.

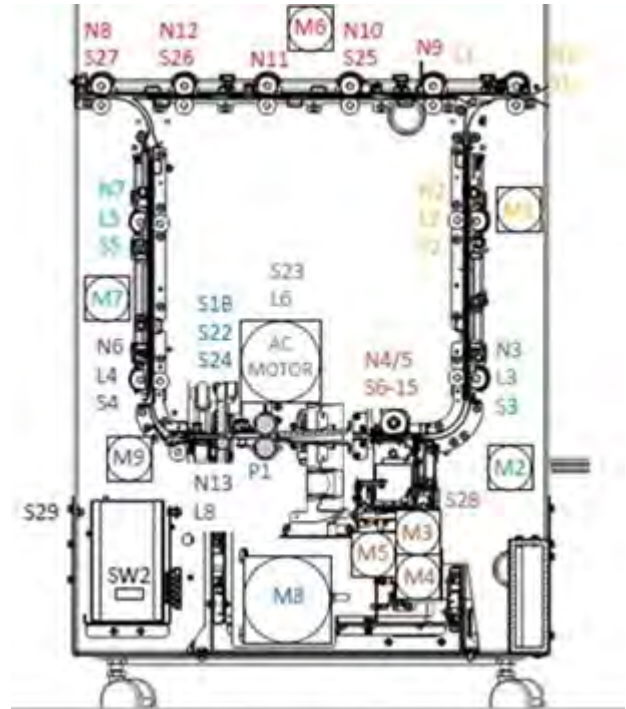
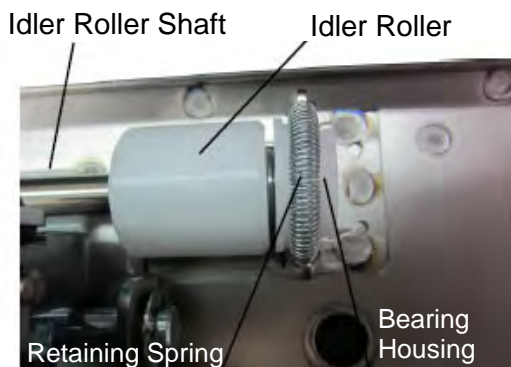

3. Inspect the bearing housing.
4. Press and rotate one roller and confirm that the other one moves in sync.
The bearing housing should slide freely in the bearing forks.
5. See [Idler Roller on page 20](#) for cleaning instructions.

Panel Latch

Magnetic latches on the entrance and exit idler panels and the upper bypass idler assembly hold the idler panels in place, which in turn keep even pressure on the idler rollers.

The latch for the acceleration idler panel ensures the acceleration panel remains firmly closed to keep even pressure on the acceleration idler roller. Inspect the latches every 1000K cycles.

1. Open the Front door.

When the idler panel is latched, the idler panel spacers (2 spacers for each idler assembly) should contact the drive panels completely.

There should not be any movement in the idler assembly either toward or away from the drive panel.



2. Open and close the idler panel and confirm that the idler springs extend.

This ensures proper idler roller pressure.



3. If necessary, follow the procedure to adjust the [Idler Panel Magnetic Latches on page 223](#).

Paper Path Timing Belt

Inspect the timing belt every 100K cycles. There are seven (7) timing belts, five (5) of which are paper path. Five of the belts at the rear of the frame have tensioner assemblies and it is these belts that should be checked.

1. Inspect all timing belts for wear, missing teeth, frayed edges, and cracks.
2. Check for proper deflection of belts.

Belts should be slightly loose with approximately 1/4" deflection.

Belts that are too loose will not drive properly and belts that are too tight can wear out prematurely or damage their driven components.

3. If replacement is necessary, see [Timing Belts on page 144](#).

Cutter Blade

Inspect the cutter blade every 30,000 cycles.



WARNING: Do not perform any inspection with the power on or electrical power supplied to the machine.

1. Open the front door and pull out the lamination drawer.
2. Remove the (4) thumbscrews holding the cutter baffle and set aside.



3. Remove the cut stick to view the blade.

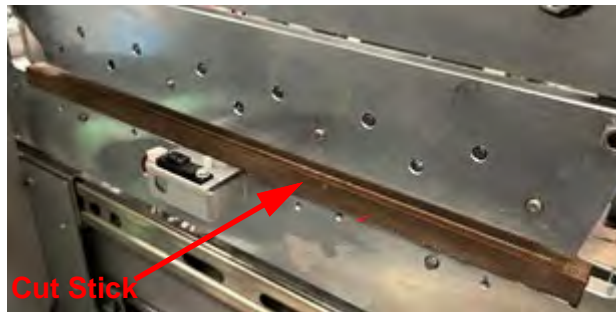

4. Visually inspect the bottom edge of the blade, that is protruding downwards below the foam on the actuator arm, for the following:
 - Adhesive build-up on the edge, which may be in small chunks.
 - Small strands of plastic from the cut stick.
 - Bits of film that did not successfully purge from the machine.
5. If any of the above is observed, follow the procedure to clean the [Cutter Blade on page 36](#).
6. Follow the steps in reverse order to replace the various parts.
7. Connect the power cord.

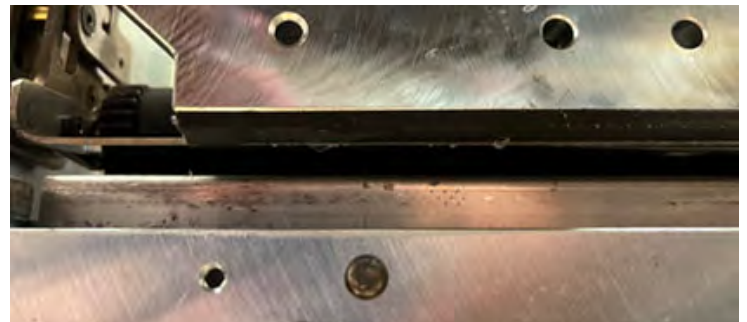

Cut Stick

Rotate the cut stick every 1,000 cuts following the instructions in the user manual. Replace after all four sides have been used.



WARNING: Do not perform any inspection with the power on or electrical power supplied to the machine.

1. Open the front door and pull out the lamination drawer.
2. Remove the (4) thumbscrews holding the cutter baffle and set aside.

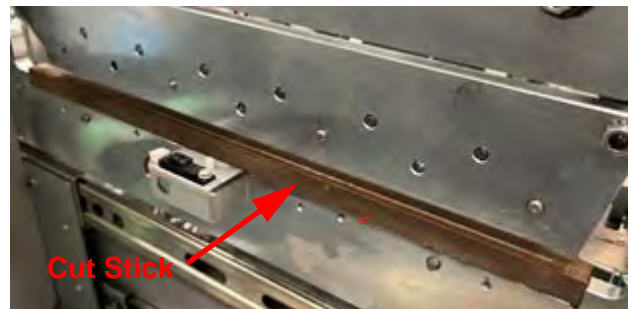

3. Remove the baffle and set it aside.
4. Remove the cut stick, keeping it in the same orientation that it was in the machine.
5. Inspect the cut groove (the one facing upwards and farthest away from you) for the following:
 - Multiple Grooves - There should only be one groove. If the stick or blade shifted during operation, then you may see multiple grooves parallel or intersecting each other. In this case, flip the cut stick to a new groove position or replace it. Refer to [Blade on page 166](#) to fix this issue.

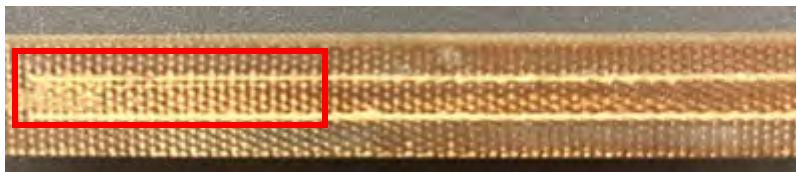

- Stick Material Fragments - As the groove expands over time it is normal for a small amount of material to break away from the edges. However, excess material can cause the cut to fail.
Removing the excess material may repair the groove and allow additional cutting.

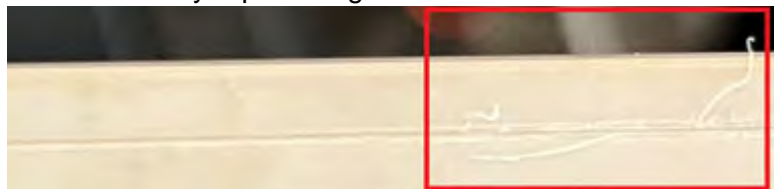

6. Follow the steps in reverse order to return the machine to working order.

Cartridge Rail

Inspect every 50K cycles.

1. Open the front door and pull out the lamination drawer.
2. Locate the cartridge tray and confirm that the bar is secure.
3. If the bar needs tightening, remove the (4) 7mm screws holding the tray..
4. Lift the tray up and tighten the (2) bottom screws.
5. Replace the tray and tighten the (4) 7mm screws.

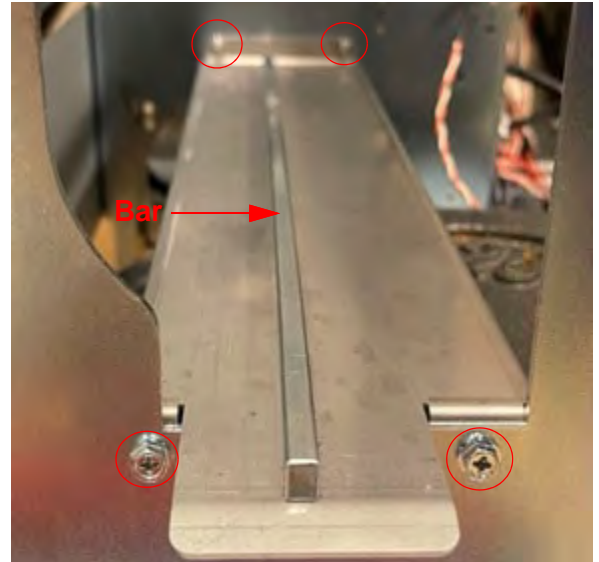

Cartridge Tray

Inspect every 50K cycles.

1. Open the front door and pull out the lamination drawer.
2. Locate the cartridge tray and confirm that the rail and locking foot are secure.
3. If the rail needs tightening, remove the (4) 7mm screws.
4. Lift the cartridge tray up and locate the (2) 5.5mm screws at the bottom of the tray and tighten them.

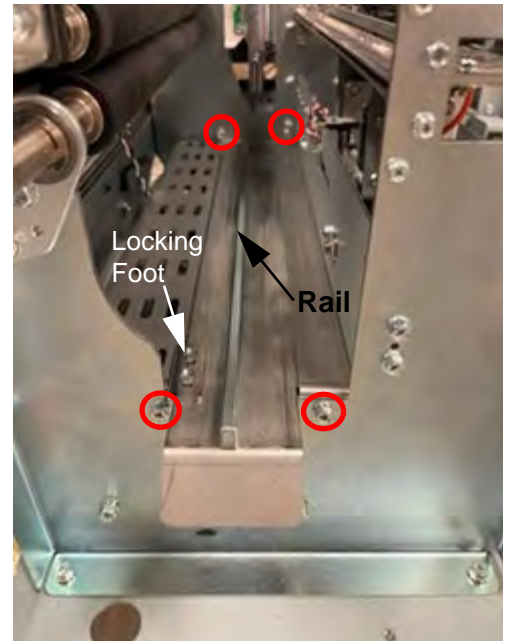

5. Replace the cartridge tray.
6. Confirm that the cartridge locking foot is secure. If the foot is loose use a 2mm Allen wrench to tighten the (2) socket screws.
7. If adjustment was made to the cartridge locking foot, ensure film alignment is correct.
8. If the alignment on the film is offset adjust the [Cartridge Foot on page 213](#).
9. When the film alignment is correct resume normal operation.

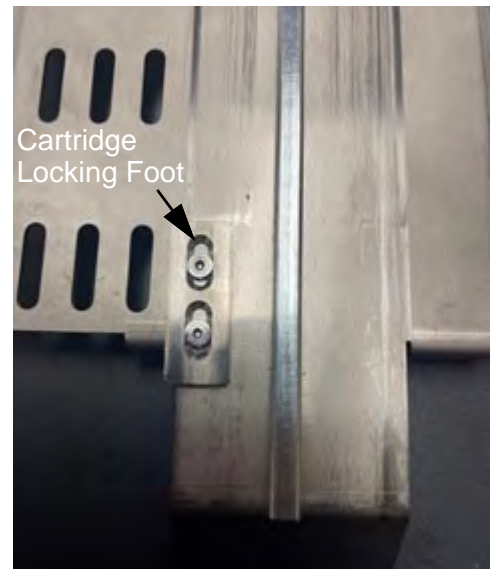

Cartridge Frame

There are specific areas of the cartridge frame that can wear over time and negatively affect the lamination performance of the machine. Follow the steps below to inspect the relevant areas of cartridge frame.

1. Inspect the frame from above to view the locking tabs.

- The cartridge clamp will lower and lock into these tabs every time the cartridge is inserted and the handle is moved to the locked position. Over time, the tabs may wear to the point that they no longer can firmly hold the cartridge in place. Be sure to inspect the front and rear tabs.
- If you notice that enough of the plastic tab has been worn off that the clamp could get caught on the edge of the tab, then replace the frame.
- If you notice the slot at the bottom of the tab has worn down enough that the clamp can shift inside of the slot when in the locked position, then replace the frame.

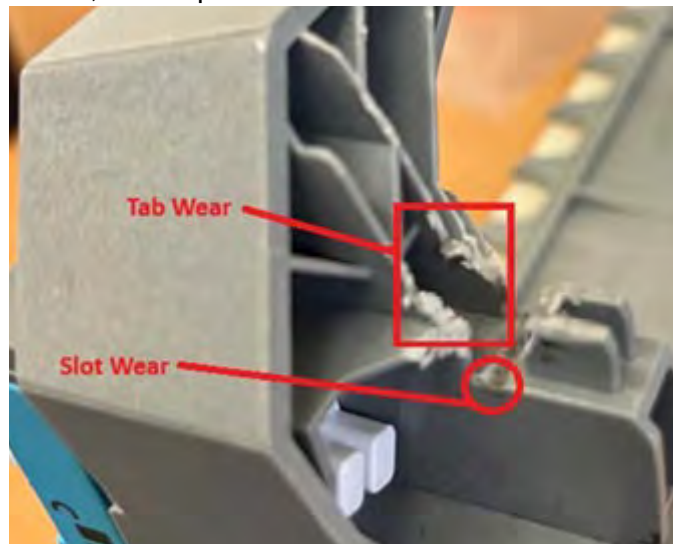

2. Inspect the frame from the front to check the foot stop surface.

- The cartridge is inserted into the drawer until it clicks into place behind the metal "foot". Over time, the plastic surface of the cartridge frame will wear down from repeatedly rubbing against the foot.
- If you notice that the plastic near the foot position has worn enough that the foot does not hold the cartridge firmly in place when installed, it is time to replace the frame.

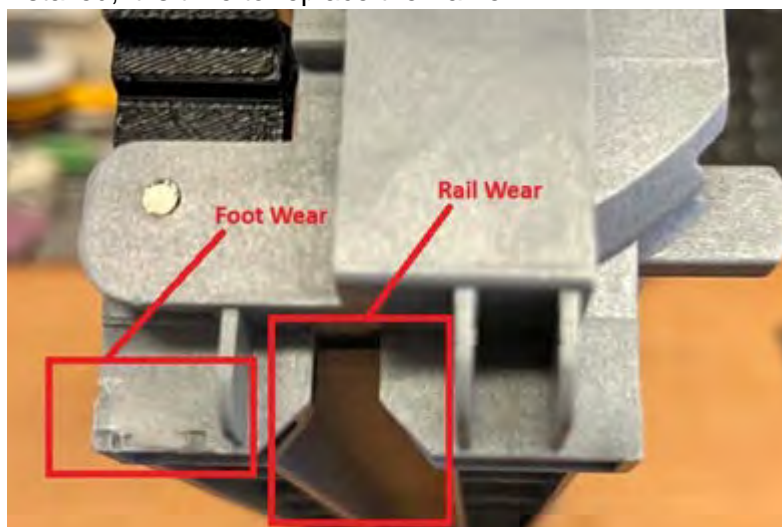

Troubleshooting

Use this chapter to troubleshoot the issue being reported by the customer. The links below show the sections relevant to the different problems, but you should always start with [Initial Troubleshooting on page 52](#).

If after running through Initial Troubleshooting the issue is not resolved, return here to go to other sections. When following the troubleshooting procedures perform each step in order until the issue is resolved. Do not skip steps.

To help you locate components, part locators (PL x.y) are added which can then be found in [Parts List on page 240](#).

Initial Troubleshooting	52
Advanced Jam Clearing	53
Roller Wraps	53
Lamination Quality	54
Film Refill	54
White Rings	54
Hub Position	54
Paper Position	54
Center Alignment.....	54
Margin	55
Skew.....	56
Film Alignment.....	57
Pressure Roller Line	57
Wrinkles	58
Paper.....	58
Film.....	58
Curl.....	59
Cross Path.....	59
Film Flow	59

Poorly Sealed Edge.....	59
Incomplete Cuts	59
Angled Cuts.....	60
Bubbles / Trapped Particles	60
Dog Ears	61
Adhesive Marks.....	61
Operator Messages	62
Troubleshooting by LCD Message	63
Close Door	63
Check Cartridge	64
Trim Tray Out - Message	66
Trim Tray Out - No Message.....	66
Trim Tray Full	67
Troubleshooting by Error Code	68
E423: Unexpected Cut	68
E451: Check Cartridge.....	68
Fault Codes	69
FAULT: PAPER AT CUTTER.....	69
FAULT: NO FILM AT CUTTER	69
FAULT: LAMINATOR DRAWER OUT	69
FAULT: NO SUPPLY	70
FAULT: TRIM PURGE BLOCKED	70
Power Faults	71
No AC Power.....	71
No DC Power	73
User Interface is Dark.....	75
Paper Jams	76
Checking for Obstructions	76
Cutter Jams	78
Clutch	80
Jam Codes	81
J1XX Jams	82
J2XX Jams	83
J3XX Jams	84
J4XX Jams	85
J408: Pressure Roller Jam.....	85
J422: Film Timeout at Cutter.....	85

J423: No Film at Cutter	86
J424: Unexpected Trail Edge	86
J5xx Jams	87
J514: No Sheet at Exit	87
Jam: Cutter Knife Down	88
Resetting the Film Cartridge	89
Sensor Checks	91
Sensor Cables	93
Sensors S1 to S5, S25 to S27	94
Sensor 1B - Cutter	96
Sensors S6 to S10	97
Sensor S11 to S15	98
Sensor S28 Align Home Sensor	99
Sensor S29 Trim Tray	100
Solenoid Checks	101
Solenoid SOL1, SOL8	101
Solenoid SOL6	101
Solenoids SOL2 - SOL3	102
Alternate solenoid inspection method: ..	102
Stepper Motor Checks	104
AC Motor Check	106

Initial Troubleshooting

Always do this procedure first before making any adjustments or repairs to the machine.

1. Review the cut stick and blade cycle counts and note their values.
 - If the cut stick exceeds 1,000 cuts, rotate the cut stick following the procedure in the user manual.
 - If the blade exceeds 250,000 cycles, replace the [Cutter Blade on page 36](#).
2. If the machine is functioning, but there are issues with the quality of the laminated output, refer to [Lamination Quality on page 54](#).
3. Check the machine for error codes
 - If there is an error or jam code on the screen, go to [page 50](#) to look for the section that corresponds with that code.
 - If no codes are on the screen, the last codes can be recovered from the log file.
4. Is there a Power Fault (No AC Power, No DC Power, No power to Control Board, Operator Panel Does Not Illuminate) go to [Power Faults on page 71](#).
5. Is the problem one of the faults that does not generate a message on the Operator Interface (Cartridge Will Not Slide Out Easily, Drawer Will Not Pull Out).
6. Go to [Advanced Jam Clearing on page 53](#).

Advanced Jam Clearing

Roller Wraps

A roller wrap can occur if the pressure rollers continue to drive the film when something has obstructed the paper path. S22 monitors the sheets leaving the cutter for lead and trail edges and will stop the laminator from operating if either edge does not appear when expected.

If the machine has repeated roller wraps:

- Perform the Area 4 check under [Checking for Obstructions on page 76](#).
- Clean the [Pressure Roller on page 24](#).
- Clean the [Lamination Paper Path on page 29](#).
- Clean the [Exit Panel \(Inner\) on page 27](#).

IMPORTANT: Do not use a blade to cut wrapped film off a roller as this can damage the roller.

To remove a roller wrap, follow the steps below.

1. Clear all jams outside of area 4 before attempting to clear the roller wrap jam.
2. Pull the lamination drawer out.

If necessary, perform a cut from the LCD user menu open the drawer.

Pulling the drawer out makes this operation easier but is not required. If the drawer cannot be opened due to the wrap, you can still follow the steps. Once the wrap is partially resolved you should be able to open the drawer.

3. Use the manual advancement knob to rotate the pressure roller counter-clockwise.

If the wrap occurred on only the lower pressure roller, disengage it using the locking lever. If the wrap occurred on the upper pressure roller, keep the cartridge lock down.

4. Continue to rewind the film until there is enough slack around the roller to get a grip on.
The drawer should be able to be pulled out at this point if not previously.
5. Disengage the upper roller, if it is still engaged, and pull the slack out until the wrap is resolved.
6. Use a blade to cut the film between the pressure roller and the refill rolls.
7. Reseal the refill following the procedure in the user manual.
8. Resume normal operation.

Lamination Quality

This section will help resolve quality issues of laminated sheets. It does not detail how to clear jams or improve output quality on sheets affected by jams.

Use this section only to improve output quality on jobs that successfully make it through the finisher.

Film Refill

If the output from the machine has quality issues, then it is possible that the film refill itself is defective or installed incorrectly. Below are a few film refill quality issues to check before moving on in this section.

White Rings

White rings are caused by variances in the plastic thickness of the film supply. These rings are formed during the manufacturing process. Extra glue marks may occur on laminated sheets in the same position as the white rings on the spool. These glue marks are typically not very noticeable unless the white rings are wide. Glue marks will fade on the film roll within 24-48 hours.



Hub Position

Each refill cartridge has four plastic hubs that are pressed into the ends of the top and bottom spools. If these hubs are loose, the refill may not fit into the cartridge frame which can then cause the film to curl or overlap as it is pulled through the machine. Check that the hubs on the refill are tight against the spools with no gaps.



Paper Position

There are three different paper position checks:

- **Center Alignment** - Sheet centering in the cross-path direction
- **Margin** - Lead edge and trail edge margins
- **Skew** - Paper angle with respect to the lamination film

Center Alignment

If the center alignment of the laminated sheet is incorrect, there are two methods to adjust it. The first method is to use the Center Alignment Screen inside of Settings on the LCD:

1. Measure how far you would like to shift the paper sheet frontwards or backwards relative to the film position.
2. On the Home screen, tap **Settings**.
3. Tap **Alignment**.
4. Enter the adjustment value inside the box at the bottom of the screen.

A positive adjustment will shift the sheet towards the back edge of the film. A negative adjustment will bring the sheet close to the front.

5. Click the **check mark** to confirm the adjustment.
6. Run an additional sheet and measure the updated alignment.
7. Make further changes to the adjustment value as needed.

If you maxed out the adjustment value (+/-4mm), then adjusting the magnet, which is the second method, will be necessary. Shifting the cartridge stop magnet's position either forwards or backwards will shift the position of each sheet inside the film. See [Cartridge on page 212](#).

Margin

There are two margin adjustment options under Settings:

- First Sheet Lead Edge Margin
- Lead and Trail Edge Margins

Before you make these adjustments, check the machine for inconsistent margin. Inconsistent margin can be caused by insufficient tension on the Pressure Roller Idler. If multiple sheets from the same job all have different margin measurements, then an adjustment using the LCD in the following sections will likely not help.

First attempt to tighten the belt by following the [Pressure Roller Idler on page 217](#) Adjustment. Once the margin is consistent between sheets, then proceed to dial in the gap size as detailed in the following procedure.

First Sheet Lead Edge Margin

The margin adjustment for the lead edge of the first sheet is in a different menu than the other margin adjustments. This is because the first sheet is tied to the purge operation, so it needs to be controlled on its own.

1. Go to the Settings menu and select **First Sheet**.
2. Measure the current gap size on the lead edge of an outputted sheet between the edge of the film and the paper.
It should be 4mm.
3. If the measured value is not 4mm, then enter the adjustment needed inside of the X box as a +/- value.
4. Press the confirm button, then run another sheet to check the adjusted sheet output.
5. Continue to make adjustments until you reach 4mm.

Lead and Trail Edge Margins

Use this adjustment to change the gap between edge of film and edge of laminated sheet in direction of paper flow. This setting applies to all sheets except for the first sheet lead edge, which can be adjusted using the "First Sheet Lead Edge Margin" above.

1. Go to the Settings menu and select **Margin**.
2. Measure the lead and trail edge gaps on an outputted sheet.
3. Enter the current values inside the respective A (LE) & B (TE) boxes.
4. Select the confirm check button and the Laminator G4 will automatically calculate the adjustment needed to set both gaps to their 4mm specification.
5. Run a new sheet through the laminator.
6. Measure the margins on the new sheet and enter the A/B values to define the margin setting even further.

7. If the margins are still not correct after multiple A/B adjustments, then instead of entering values inside of the A & B section, edit the Gap and Cut boxes (located towards the bottom of the screen). Use the example below to understand how Gap and Cut Adjustments function and can be used to make small changes to the sheet margin.



Skew

If laminated sheets are turned at an angle inside of the film then they are skewed and a skew adjustment is required. Ensure this is a skew problem and not an angled cut problem by inspecting an outputted sheet. Check that the corners where the film was cut are 90 degrees. If they are drastically off-square, refer to [Angled Cuts on page 60](#).

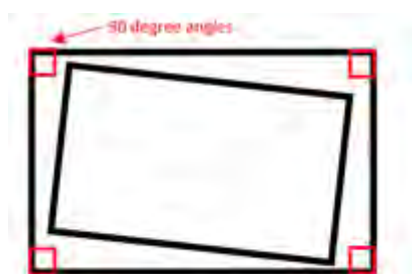

Sheet skewed along its length.

If the cut appears square, proceed with the following skew adjustment steps.

1. Go to the Settings menu and select **Skew**.
2. Use the +/- buttons to edit the current skew value.

More positive will turn the sheet clockwise inside of the film. A more negative value will turn the sheet counter-clockwise.

3. Continue to make small adjustments of around 0.5 at a time, running a few sheets to test how the output is changing with each adjustment, until the skew on the sheet is correct.

If skew is correct on the lead edge of the sheet, but the trail edge of the sheet still seems skewed on longer paper sizes, then you may need to make a further adjustment to the machine.

Follow the procedure [Locking Mechanism Springs on page 237](#) to make adjustments.

NOTE: The springs need to be set to the exact same compressed length on both sides of the locking mechanism or the sheet will skew as it runs through the rollers.

Test a few more sheets after adjusting the locking mechanism springs to ensure the rear of the sheet is no longer skewed.

Film Alignment

Use this procedure if the top and bottom layers of film on an outputted sheet are misaligned. When misalignment occurs the adhesive on the of the film layer will be exposed on the front and rear edges. Touch the front/rear edge of a laminated sheet to see if you can feel the adhesive on the sheet.

1. Remove the current film supply from the cartridge frame and re-seat it.

It is possible the cartridge was not completely seated into the cut-outs and was in the incorrect position during lamination.

2. If the misalignment persists, swap the current film with a different roll.

On rare occasion, supply may be manufactured incorrectly creating a misalignment. If a new cartridge refill fixes the problem, then the issue is not related to the machine itself, but rather a defective film refill.

3. If multiple film supplies are all experiencing identical film misalignment, [Stop Magnet on page 212](#) will need to be adjusted.

If the bottom layer of film is exposed in the front (sticky portion facing up), then you will need to tilt the top of the magnet toward the user. If the top layer is exposed (sticky portion facing down), tilt the bottom of the magnet away from the user.

4. After adjusting the cartridge tilt, you will need to also perform [Stop Bracket on page 213](#) and [Cartridge Foot on page 213](#) adjustments in order to ensure the cartridge is held tightly in place with the new magnet stop position.



Pressure Roller Line

The pressure roller line is caused by the sheet stopping briefly inside the pressure rollers during lamination. This behavior is normal and the line cannot be eliminated completely. The line is more noticeable on darker paper and prints.

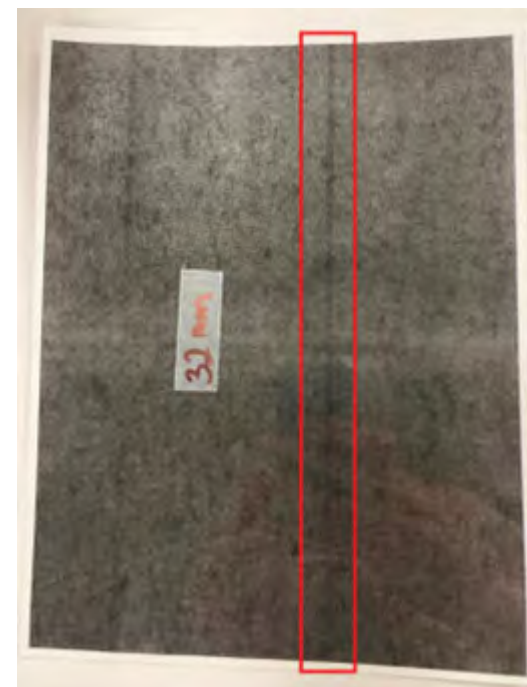

If the line is excessively thick, it can be improved by loosening the locking mechanism springs slightly ~1-2mm. Follow the adjustment procedure for [Locking Mechanism Springs on page 237](#).

IMPORTANT: Ensure the springs are set to the same height when the adjustment is completed.

Wrinkles

Paper

These wrinkles appear as small creases in the paper inside of a laminated sheet. The film may still appear smooth on top of the creases inside. This issue is connected to the pressure rollers for which the pressure along the rollers may be inconsistent and cause the sheet to bow inwards as it runs through them.



1. Inspect the rollers for damage (see [Pressure Roller on page 24](#)).
2. If any damage is present on the rubber surface, replace the damaged roller (Lower or Pressure) using the repair procedure [Rollers on page 193](#).
3. If no damage is present, but the rollers appear dirty or have small bits of debris stuck to the rubber, clean the roller (see [Pressure Roller on page 24](#)).
4. Check that the toggle springs are set correctly by referencing the adjustment procedure for [Locking Mechanism Springs on page 237](#).

Film

Wrinkles to the film can often occur after installing a new film refill. Occasionally the pressure rollers need to run a few meters of film before the film smooths out again. If a sheet is sent through the system before getting the wrinkles out of the film, the machine will likely jam around the cutter area.



1. Check that the film can be fed through the pressure rollers, underneath the cutter blade, and out of the cutter outfeed baffle using the manual adjustment knob.
2. If the above step is not possible, back the film out of the machine and refer to the procedure on [Resetting the Film Cartridge on page 89](#).
3. Once wrinkled film passes through the paper path successfully, go to the User Functions menu on the LCD and run the "Film Proof Test" commands one at a time to run the film through the system until the wrinkles all disappear.

Opening and closing the locking mechanism between proofs can help this issue resolve more quickly. Be sure to inspect for improvement and remove the proof portion in section 4 of the machine between each command.

Curl

Cross Path

Cross path film curl can be caused by a defective film supply. Try switching to a new film supply refill. If the issue persists, follow the recommendations in the “Film Flow Curl” section below.



Film Flow

Unlike cross path curl, film flow curl is not usually caused by the film supply. Curl in the direction of the film flow will require a machine adjustment – specifically, the locking mechanism & pressure rollers.



1. Inspect and clean the [Pressure Roller on page 24](#).
2. Check that the pressure rollers come together evenly in the engage handle position. Make sure there are no obstructions between the rollers.

3. If the toggle mechanism seems loose, remove it from the lamination drawer following the removal procedure for the [Locking Mechanism on page 195](#). Also check if other components are loose and need to be tightened.
4. Check that the toggle spring lengths are accurate and even following the procedure [Locking Mechanism Springs on page 237](#).
5. If there is a large amount of film misalignment (>1mm), then attempt to resolve this by referencing [Film Alignment on page 57](#).
6. After making adjustments and repairs, run a new job to check if the curl has been eliminated.

Poorly Sealed Edge

A poorly sealed edge can be caused by insufficient roller pressure. Reference [Locking Mechanism Springs on page 237](#) for information on increasing the spring pressure.

Incomplete Cuts



An incomplete cut will result in a machine jam because the front sheet will not be able to separate from the laminated sheet behind it. A J422-No Trail Edge Jam error message is another indicator that the machine may not be cutting the sheets completely.

1. Go to the Settings menu and select **Cut Stick**.

If this value is over 1,000 the cut stick surface needs to be changed. Refer to [Cut Stick on page 46](#) for information on inspecting and changing to a new cut stick surface.

If the value is not to 1,000 cuts, then follow the steps below until the problem is resolved.

2. Take the cut stick out of the machine (follow instructions for [Cut Stick on page 46](#)) and measure the thickness of the stick at 5 points along its length using calipers or a micrometer.
3. Ensure the stick is between 12.4-13.0mm in all points.
If the stick does not conform to these measurements it is defective and should be replaced.
4. Inspect the stick for signs of damage or imperfections along the surface (besides the groove itself).
5. If the cut is missing on one end of the sheet, follow the procedure for [Pivot on page 230](#).
6. If the cut is missing in the center, tighten the connecting rod spring slightly using the procedure [Connecting Rod Spring on page 233](#).

Angled Cuts

An angled cut is linked to skew. There are three options below that could describe the specific angle cut situation you are experiencing.

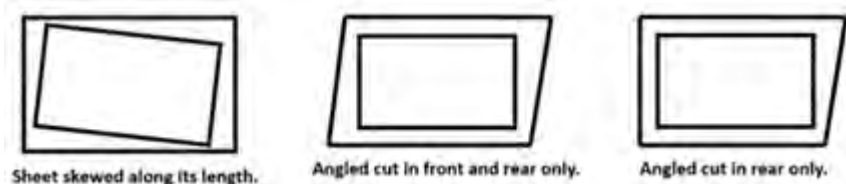

1. If the sheet is skewed all the way across its length, adjust the [Skew on page 56](#).

2. If the sheet is skewed only in the rear of the sheet, but not in the front, then a locking mechanism spring pressure adjustment may be required (see [Skew on page 56](#)).
3. If the lead edge and trail edge cuts are angled, but the sheet is not skewed in the middle (along its length), then a physical adjustment to the cutter may be required.
 - Ensure the pivot on the cutter is flush with the frame (see [Pivot on page 230](#)). If the film is cutting successfully on both edges, but is missing in the middle, then a pivot adjustment is no longer required. Instead, the connecting rod length or spring length must be adjusted. See [Connecting Rod Spring on page 233](#).
 - Ensure the cutter links are tight by referencing [Clutch on page 164](#).

Bubbles / Trapped Particles

Bubbles or trapped particles in the film can look like glue marks at first. However, unlike glue marks, these bubbles will not fade over time. Bubbles are caused by small particles getting in between the two layers of film and preventing the film from sealing smoothly. The issue is most likely a defective film supply due to the film manufacturer not using a clean room, which then allows particles to enter the film rolls during the manufacturing process.

To ensure that particles are not being introduced during the lamination process:

NOTE: The trim tray pieces can have small pieces of debris that may have been cleared at the start of the job or entered the tray during storage. Do not worry about dust/debris on film pieces inside of the trim tray.

1. The pressure rollers should routinely be inspected for dirt or debris and cleaned using the procedure for [Pressure Roller on page 24](#) to ensure none of these particles are entering the film during the lamination process.
2. Clean the sheet metal parts following the procedure for the [Lamination Paper Path on page 29](#).

Dog Ears

Dog ears can be identified as a folded corner on the lead edge of a sheet.



These usually occur when a sheet hits a small obstruction in the paper path but is still able to make it through the machine without jamming. Most dog ears are caused in area 3 of the machine. Try these two physical adjustments in the order listed:

- Adjust the curved panel height, see [Paper Path on page 216](#).
- Adjust the [Drawer Switch on page 236](#).

Adhesive Marks

Adhesive marks (glue marks) can appear as small circles on the surface of the film. These marks will disappear on their own within 24-28 hours after laminating a sheet of paper.



Operator Messages

The LCD will display status messages and fault codes.

For each message, perform the initial action. If the initial action does not resolve the issue, proceed to the that message's trouble shooting procedure.

Message	Description	Initial Action
CLOSE DOOR	The front door is open.	Close the front door.
READY	The system is ready.	Proceed as normal.
BYPASS MODE	The system has been put into bypass mode through the user settings.	Turn off bypass mode in the user settings.

Message	Description	Action
CHECK CARTRIDGE	Indicates the machine cannot detect the cartridge chip.	Remove the cartridge and reinsert it. See Check Cartridge on page 64
TRIM TRAY OUT	The trim tray has not been inserted all the way.	Open the door, reseal the trim tray, and then close the door. See Trim Tray Out - Message on page 66 or Trim Tray Out - No Message on page 66 .
TRIM TRAY FULL	The trim tray is full and required emptying.	Open the door, remove and empty the trim tray, reinstall the tray, and close the door. See Trim Tray Full on page 67 .

Troubleshooting by LCD Message

Close Door



WARNING: Moving Parts, keep hands clear of nips and belts when the Interlock Cheater is inserted.

The CLOSE DOOR message indicates that the front door is open or not completely closed.

1. Check that the front door is closed.

The Front Doors is closed.

Yes- Go to step 2; **No-** Close the front door and return to normal operation.

2. Insert an interlock cheater into the door interlock switch SW4.
3. Check if the “Close Front Door” message is displayed.

The message is displayed.

Yes- Go to step 4; **No-** Adjust the [Door Latch on page 209](#) and return to normal operation.

4. Remove the [Rear Cover on page 110](#) and check if the interlock cable (7725566) is connected at J8 at the main control board.

Interlock cable is connected at J8.

Yes- Go to step 5; **No-** Make the connection and return to normal operation.

5. Switch OFF the machine and unplug the power cord.
6. Remove the (2) M4 nuts that hold the interlock switch bracket and inspect the connections at the interlock switch (see [Interlock Switch on page 116](#) for photos of the connections).

Interlock cable is connected at the Interlock switch.

Yes- Go to step 7; **No-** Make the connection and return to normal operation.

7. Inspect the connection at J17 on the main control board. It is a 16 pin connector to a 16 pin terminal.

The connection at J17 is good.

Yes- Go to step 8; **No-** Make the connection and return to normal operation.

8. See [Firmware Update / Save Logs on page 14](#) to re-flash the firmware.

Re-flashing the firmware clears the fault.

Yes- Return to normal operation; **No-** Go to step 9

9. Replace the [Interlock Switch on page 116](#).

Replacing the switch clears the fault.

Yes- Return to normal operation; **No-** Go to step 10.

10. Replace the interlock switch cable (7725566).

Replacing the cable clears the fault.

Yes- Return to normal operation; **No-** Replace the [Main Control Board on page 203](#).

Check Cartridge

The CHECK CARTRIDGE message indicates that the film cartridge is either missing or not fully installed.

1. Open the front door and remove and re-insert the film cartridge so that contact is made between the film chip board and the chip reader.

This clears the fault.

Yes- Return to normal operation; **No-** Go to step 2

2. Replace the film cartridge with a new one.

This clears the fault.

Yes- Return to normal operation; **No-** Go to step 3

3. Remove the cartridge and check that the pins on chip reader are not damaged or missing.

Pins are missing or damaged.

Yes- Replace the [Chip Reader on page 204](#); **No-** Go to step 4

4. Is the chip reader loose on the bracket.

Yes- Secure board on the bracket; **No-** Go to step 5

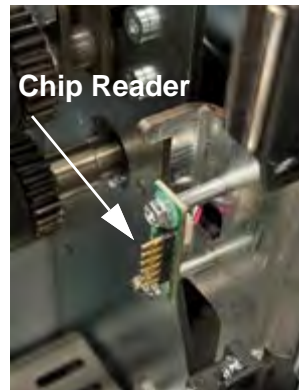
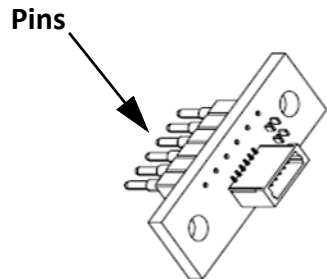

5. Remove the [Rear Cover on page 208](#), locate the chip reader and confirm that the connection is properly seated.

Yes- Connection is secure; **No-** Fully seat the connector.



6. Locate the Chip Reader cable 7725161 and check the continuity to ensure the wire is not faulty.

Continuity test fails.

Yes- Replace the cable; **No-** Go to step 7

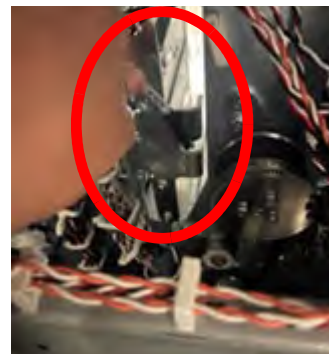

7. Perform the adjustment for the [Stop Magnet on page 212](#). If the error message remains proceed to step 8.
8. Perform the adjustment for the [Rail Height on page 215](#).
9. If the error message remains, follow instructions to replace the [Chip Reader on page 204](#).
10. If the error message remains, follow instructions to replace the [Main Control Board on page 203](#) (PL 6.1).
11. If all of the above actions have been executed and the message still remains, escalate to next level of support.

Trim Tray Out - Message

This message is displayed when the trim tray is removed from the machine or when the trim tray is not fully inserted.

1. Open the front door and insert the trim tray firmly.

This clears the fault.

Yes- Return to normal operation; **No-** Go to step 2

2. Inspect the spring clip on the trim tray home switch. If the spring clip is broken, replace the [Trim Tray on page 172](#).

This clears the fault.

Yes- Return to normal operation; **No-** Go to step 3

3. Do a firmware upgrade (see [Firmware Update / Save Logs on page 14](#)).

Re-flashing the firmware clears the fault.

Yes- Return to normal operation; **No-** Go to step 4

4. Replace the [Trim Tray on page 172](#).

This clears the fault.

Yes- Return to normal operation; **No-** Go to step 5

5. Replace Cable (7725565) See [Wiring on page 263](#).

This clears the fault.

Yes- Return to normal operation; **No-** Replace the [Main Control Board on page 203](#).

Trim Tray Out - No Message

The trim tray is out of the machine but no message is displayed.

1. Make sure the (2) spade connectors to the trim tray home switch are securely inserted. (See [Trim Tray on page 172](#))

Connectors are securely connected.

Yes- Go to step 2; **No-** Securely connect the (2) spade connectors

2. Remove the [Rear Cover on page 110](#) and check that cable 7725565 is connected to J27 at the main control board (See [Wiring on page 263](#))

See the [Sensor Cables on page 93](#) for cable numbers.

The connection is good.

Yes- Go to step 3; **No-** Make the connection and return to normal operation.

3. Do a firmware upgrade (see [Firmware Update / Save Logs on page 14](#)).

Re-flashing the firmware clears the fault.

Yes- Return to normal operation; **No-** Go to step 4

4. Replace the [Trim Tray on page 172](#).

This clears the fault.

Yes- Return to normal operation; **No-** Go to step 5

5. Replace Cable 7725565 (see [Trim Level Emitter on page 173](#) and [Trim Level Receiver on page 173](#)).

This clears the fault.

Yes- Return to normal operation; **No-** Replace the [Main Control Board on page 203](#).

Trim Tray Full

The “Trim Tray Full” message is displayed when the trim fill capacity is exceeded.

1. Remove the trim tray and empty the trim scraps.

This clears the fault.

Yes- Return to normal operation **No**- Go to step 2

2. Remove the trim tray and check if the trim level emitter and trim level receiver are plugged in.

The trim level emitter and receiver are located in the trim tray cavity in the lower portion of the front frame. See [Trim Level Emitter on page 173](#) and [Trim Level Receiver on page 173](#) for more details.

The connections are good.

Yes- Remove the [Rear Cover on page 110](#) and go to step 4;

No- Make the connection and return to normal operation.

3. Check if cable 7725565 is connected to J27 at the Main Control Board (see [Wiring on page 263](#)).

The connection is good.

Yes- Go to step 5; **No**- Make the connection and return to normal operation.

4. Perform the S29 sensor check on [page 100](#).
5. Do a Firmware Upgrade (see [Firmware Update / Save Logs on page 14](#)) to re-flash the firmware.

Re-flashing the firmware clears the fault.

Yes- Return to normal operation; **No**- Go to step 6

6. Replace the [Trim Level Emitter on page 173](#).

This clears the fault

Yes- Return to normal operation; **No**- Go to step 7

6. Replace the [Trim Level Receiver on page 173](#).

This clears the fault.

Yes- Return to normal operation; **No**- Go to step 8.

7. Replace cable 7725565 (See [Wiring on page 263](#))

This clears the fault.

Yes- Return to normal operation; **No**- Replace the [Main Control Board on page 203](#).

Troubleshooting by Error Code

Fault	Sensor	Details
E423: UNEXPECTED CUT	S23	This error is displayed if S23 detected a second rotation of the cutter flag. This should not cause a jam, but if a jam occurs and this was detected, this error message should be displayed instead of whatever caused the jam. This should also be saved to the log file.
E451: CHECK CARTRIDGE	Chip Reader	This indicates the wrong supply is being used.
E452: CHECK CARTRIDGE	Chip Reader	This indicates there was a read error on the cartridge.

E423: Unexpected Cut

This error occurs when a J423 NO FILM AT CUTTER jam occurs accompanied by the KNIFE HOME position sensor S23 detecting an extra activation of the cutter. When these jams occur, they will be logged in the log file.

1. Perform the cleaning procedure for the [Cutter Clutch on page 33](#).
2. Troubleshoot the clutch for damage, see [Sensor Checks on page 91](#).
 - If damage is present, replace the [Clutch on page 164](#) (PL 4.1).
3. If the problem persists, escalate to the next level of support.

E451: Check Cartridge

This error occurs when the film meant for a different model the laminator is inserted into the machine. See [Check Cartridge on page 64](#).

E452: Check Cartridge

This error occurs when the chip reader cannot read the chip on the refill. See [Check Cartridge on page 64](#).

Fault Codes

Fault	Sensor	Details
FAULT: PAPER AT CUTTER	S1B	S1B is detected as blocked.
FAULT: TRIM TRAY FULL	S29	Film is detected protruding above the trim tray. Cleared after the SW2 cycles, S29 is unblock, and the interlock has cycled.
FAULT: TRIM PURGE BLOCKED	S29	Film or paper is detected protruding above the trim tray at an unexpected time. Cleared after S29 is unblocked and the interlock is cycled. (SW2 does not need to be cycled to clear).
FAULT: INSERT TRIM TRAY	SW 2	SW 2 switch does not detect the bin.
FAULT: PUSH IN LAMINATOR	SW 3	SW 3 switch does not detect the lamination drawer.

FAULT: PAPER AT CUTTER

This occurs when a jam condition is not completely cleared. Advance the knob on the lamination drawer until the message is cleared and then advance the knob one additional rotation. Perform a cutter cycle and remove the sheet from Area 5.

FAULT: NO FILM AT CUTTER

This fault occurs when S24 does not detect the laminate when performing an initial feed

1. Check that the cartridge is loaded correctly.
2. Perform the sensor check for S24
3. Check M8 functions by performing a Trim Film & Eject user function.
4. Escalate to the next level of support.

FAULT: LAMINATOR DRAWER OUT

This fault occurs when switch 3 detects that the laminator drawer is out when the door is closed.

1. Check for anything that may be obstructing the drawer's travel from engaging the drawer catch.
If the drawer catch is not engaging, clear the obstruction.
2. Pull out the drawer and push it back firmly.
3. Perform the [Alignment Pin on page 235](#) adjustment procedure.
4. Adjust the [Drawer Switch on page 236](#).
5. If the switch is being pressed, but the machine is not recognizing as closed, replace the switch (7301296 on PL 5.1).
6. Check the cable continuity of cable 7725510. Replace if needed. See [Wiring on page 263](#).
7. Replace the [Main Control Board on page 203](#).
8. Escalate to the next level of support.

FAULT: NO SUPPLY

This occurs when the machine cannot detect a film supply.

Perform the steps for [Check Cartridge on page 64](#).

FAULT: TRIM PURGE BLOCKED

This occurs when film or paper is detected protruding above the trim tray at an unexpected time. To clear this, S29 must be unblocked when the interlock is cycled.

If this cannot be cleared, or occurs when nothing is blocking the sensor, perform the procedures in [Trim Tray Full on page 67](#).

Power Faults

No AC Power

The UI does not illuminate and the laminator does not operate.

1. Check that the power cord is attached to the AC filter on the rear of the machine.

Power Cord is attached to AC Filter.

Yes- Go to step 2; **No-** Attach the power cord.

2. Check that the power cord is properly plugged into the wall.

Power Cord is plugged into the wall.

Yes- Go to step 3; **No-** Plug in the power cord.

3. Disconnect the power cord from the power source and check for input voltage - 110 VAC (60 Hz) or 240 VAC (50 Hz) - at the power receptacle.

AC power is present at the receptacle.

Yes- Go to step 4; **No-** If there is no power at the outlet, ask the customer to call an electrician to restore the AC power.

4. Reconnect the power cord to laminator.
5. Check that ground wire (7715525) is connected to the ground and to the AC filter.

Ground wire is connected.

Yes- Go to step 6; **No-** Connect the ground wire.

6. Check that cable 7715498 is connected at the AC filter.

Cable is connected at the AC filter.

Yes- Go to step 7; **No-** Connect the cable.

7. Check that cable 7715498 is connected to the communication board at pin J14.

Cable is connected to the communication board.

Yes- Go to step 8; **No-** Connect cable 7715498 to the communication board.

8. Check the fuse on the communications board.

Fuse is okay

Yes- Go to step 9; **No-** Replace the fuse.

9. Check that wire 7715494 is connected to pin J15 on the communications board.

Wire 7715494 is connected to pin J15 on the communications board.

Yes- Go to step 10; **No-** Connect wire 7715494 to pin J15 on the communications board.

10. Check that wire 7715494 is connected to pin J4 on the control board.

Wire 7715494 is connected to Pin J4 on the control board.

Yes- Go to step 11; **No-** Connect wire 7715494 to pin J4 on the control board.

11. Check for input voltage - 110 VAC (60 Hz) or 240 VAC (50 Hz) - at the AC filter.

There is AC power at the AC filter.

Yes- Go to step 12; **No-** Replace the AC power cord to the AC filter.

12. Check for input voltage - 110 VAC (60 Hz) or 240 VAC (50 Hz) – on cable 7715498 at the AC filter (BRN & BLU wires).

There is AC power on Cable 7715498 at the AC filter.

Yes- Go step 13; **No-** Replace [AC Filter on page 202](#).

13. Check for input voltage - 110 VAC (60 Hz) or 240 VAC (50 Hz) – on cable 7715498 at the pin J14 on the communications board (BRN & BLU wires).

There is AC power on Cable 7715498 at Pin J14 on the communications board.

Yes- Go to step 14; **No-** Replace cable 7715498.

14. Check for input voltage - 110 VAC (60 Hz) or 240 VAC (50 Hz) – on cable 7715494 at pin J15 on the communications board (BLU & BRN wires).

There is AC power on cable 7715494 at Pin J15 the communications board.

Yes- Go to step 15; **No-** Replace [Communication Board on page 204](#).

15. Check for input voltage - 110 VAC (60 Hz) or 240 VAC (50 Hz) – on cable 7715494 at pin J4 on the control board (BLU & BRN wires).

There is AC power on Cable 7715494 at Pin J4 the control board.

Yes- Replace the [Main Control Board on page 203](#); **No-** Replace cable 7715494

No DC Power



WARNING: Moving Parts, keep hands clear of nips and the belts when the Interlock Cheater is inserted.



DANGER: HIGH VOLTAGE Do not touch the open terminals of the power supply or any other connector with the AC power cord connected. The machine components contain dangerous electrical voltages that can result in electrical shock and possible serious injury.

1. Remove the [Rear Cover on page 110](#).
2. Plug in the AC power cord and turn the AC power switch to ON.
3. Check the LEDs on the control board.
 - With the front door closed there will be (4) LEDs that will be lit.
 - With the front door open, there will be (3) LEDs that will be lit.

The LEDs are lit.

Yes- Go to step 9; **No-** Go to step 4.

4. Check for line voltage on wire 7715493 at connector J3 on the main control board (See [Wiring on page 263](#)).

There is line voltage.

Yes- Go to step 5; **No-** Follow steps for [No AC Power on page 71](#).

5. Check the following connections:
 - Cable 7715492 at J1 at the main control board.
 - Cable 7715493 at J3 at the main control board.

Connections are good.

Yes- Go to step 6; **No-** Make the connections then return to normal operation.

6. Remove the [24V Power Supply on page 201](#).
7. With the power supply outside the machine, make the connections at J1 and J3 and the ground cable.
8. Check if the LED in the power supply is lit.

LED is lit

Yes- Go to step 10; **No-** Go to step 9

9. Replace cable 7715493.

This clears the fault.

Yes- Return to normal operation; **No-** Replace the [24V Power Supply on page 201](#).

10. Check if there is no 24V power to any other components like a solenoid or a stepper motor.

There is no 24V power to any other components

Yes- Replace [Main Control Board on page 203](#); **No-** Go to step 11

11. Check for 24 VDC on cable 7715492 at connector J1 on the control board.
 - Pin 1 = ORG Wire
 - Pin 2 = ORG Wire
 - Pin 3 = ORG Wire
 - Pin 6 = BLK Wire
 - Pin 7 = BLK Wire
 - Pin 8 = BLK Wire

There is 24 VDC at Connector J1 on the control board.

Yes- Go to step 12; **No-** Replace cable 7715492.

12. Determine if you have been directed here from another troubleshooting procedure because there is no 24 VDC power output from the control board to another component.

There is 24 VDC power output from the control board to another component.

Yes- Return the machine to normal operation; **No-** Replace [Main Control Board on page 203](#).

User Interface is Dark



DANGER: HIGH VOLTAGE Do not perform repair activities with the power on or electrical power supplied to the machine. Some machine components contain dangerous electrical voltages that can result in electrical shock and possible serious injury.

Use this procedure when the UI does not illuminate.

1. Unplug the machine and plug it back in after 20 seconds.

The User Interface illuminates.

Yes- Normal operation; **No**- Go to step 2

2. Remove the [Rear Cover on page 110](#).
3. Plug in the AC power cord and turn on the power switch.
4. Check the LEDs on the control board.

The LEDs are labeled and all are located near the center of the control board.

- LED3: 24V
- LED5: 3.3V
- LED1: 5V

The LEDs are lit.

Yes- Go to step 5; **No**- Follow steps for [No DC Power on page 73](#).

5. Check that LCD cable is connected at connector J36 on the control board (See [Wiring on page 263](#)).

Cable 7724421 is connected at connector J36.

Yes- Go to step 6; **No**- Connect cable 7724421

6. Check that LCD cable 7724421 is connected at the adapter PCB on the top cover assembly.

Do the following to access the LCD cable.

- Open the front door.
- Check if cable (large flat ribbon cable) is connected at the LCD adapter PCB.
- If necessary, remove the top cover to better access the LCD display assembly.

Cable 7724421 is connected at the adapter PCB.

Yes- Go to step 7; **No**- Connect cable 7715523. Power cycle the laminator to confirm the fault is cleared.

7. Check if the adapter ribbon cable is connected at the adapter PCB and the LCD display.

LCD cable 7724422 is connected.

Yes- Go to step 8; **No**- Connect the Adapter Ribbon Cable. Unplug and plug in the machine to confirm if the fault is cleared.

8. Inspect the LCD display 7723665.

LCD Display looks OK

Yes- Go to step 9; **No**- Replace [LCD Display on page 119](#)

9. Replace the Adapter Ribbon Cable and LCD Ribbon Cable. Power cycle the laminator.

This resolves the issue

Yes- Normal Operation; **No**- Go to step 10.

10. Replace the [Main Control Board on page 203](#).

This resolves the issue

Yes- Normal Operation; **No**- Escalate to next level of support

Paper Jams

This section describes paper jams based on the position of the lead edge/trail edge of the first jammed sheet and by jam codes.

Checking for Obstructions

When inspecting for obstruction to paper path, look for any ripped pieces of paper or any other objects like loose fasteners along the paper path. A few key areas to inspect are shown below:

Area 1 (Entrance and Bypass)

1. Open the front door.
2. Open the bypass panel.
3. Inspect the gap between the drive roller and the sheet metal panel for any objects.

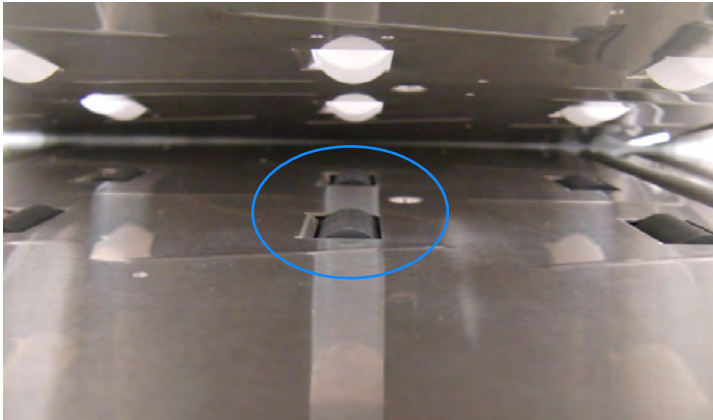

Area 2 (Entrance Idler Panel Assembly)

1. At the top of Area 2, check if there is a 2 to 3mm gap for sheet flow.
2. If the lower entrance panel is bent, replace it (see [Lower Entrance Panel on page 123](#)); If the inner entrance panel is bent, replace it (see [Inner Entrance Panel on page 125](#)).

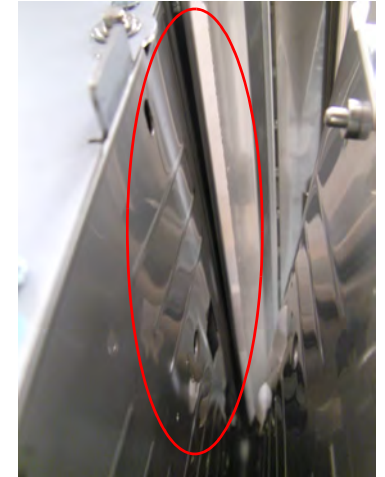

Area 3 (Paper Path)

1. Open the front door and pull out the lamination drawer.
2. Remove the film cartridge.
3. Look for sheets stuck in Area 3.
4. If there are no sheets, check that **sensor 3** is working (see [Sensors S1 to S5, S25 to S27 on page 94](#)).
5. If the sensor is fully functional, ensure panel 3 is properly latched.
6. If panel 3 is not latching correctly, adjust the magnet (see [Paper Path on page 216](#)).



7. If panel 3 is properly latched, look for obstructions in aligner module.



8. If no obstructions are present, ensure that film cartridge is not broken or damaged ([Cartridge Frame on page 49](#)).
9. If the film cartridge is not damaged or broken, check that the sensors are fully functioning ([User Functions on page 11](#)).
10. If the problem is not fixed, escalate to next level of support.

Area 4 (Cartridge Area)

Follow these steps when the first sheet jam is occurring in the cartridge area.

If the sheet has stopped in the pressure roller, partially laminated with the lead edge undamaged and the next sheet had crashed into its trail edge. Check the following:



1. Inspect the cartridge for damage ([Cartridge Frame on page 49](#)).
Damage could allow the cartridge to touch the rollers resulting in motor stalls.
2. Inspect the area after the cutter for small pieces of laminate that may not have been purged properly. This can be checked by removing the cartridge and looking through the unlocked pressure rollers. Alternatively, remove the cutter out feed guide to look from the other end.
3. Inspect the lamination roll for damage, as described in the user manual.
4. Inspect the pressure roller gears for damage or obstructions
5. Inspect the pressure rollers.
6. Inspect the [Idler Roller on page 20](#).
If the rail is loose or damaged it can allow the cartridge to touch the rollers resulting in motor stalls.
7. Check that the M8 belt tension is correct following the adjustment procedure [Steering Motor Belt on page 222](#).
8. Inspect S6-10 ([Sensors S6 to S10 on page 97](#)).
9. Try using a different cartridge and refill.

Cutter Jams

1. Remove the [Rear Cover on page 110](#).
2. Locate the cutter shaft at the rear of machine.

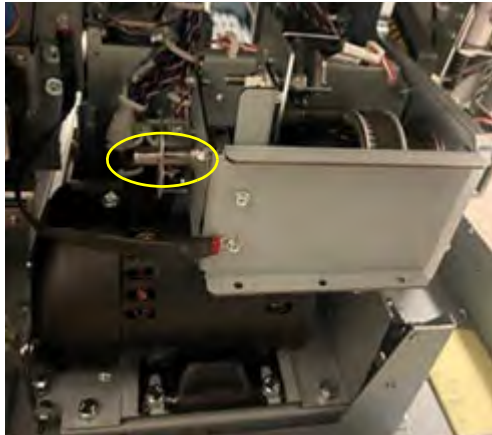

3. Use a 10mm wrench to turn the shaft clockwise (forward).



CAUTION: Use Extreme caution when turning the shaft and grip the wrench tightly. Once the blade is unjammed the wrench will forcefully move forward.



4. Confirm that the shaft is in the proper home position when the blade is unjammed.

If the shaft is not in the home position preform the [Clutch Indexing on page 229](#) adjustment.

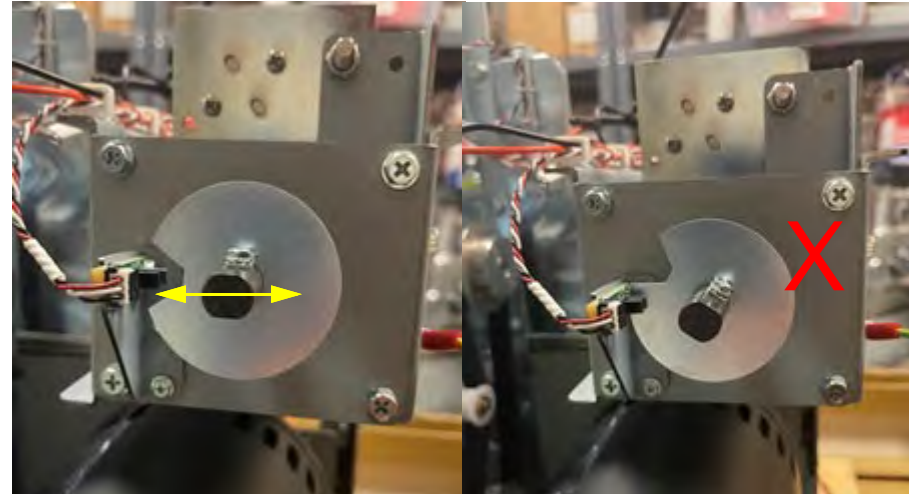

5. Verify the encoder disc window is not blocking the sensor when the blade is in the proper position.

This will also ensure that the shaft is in the home position.

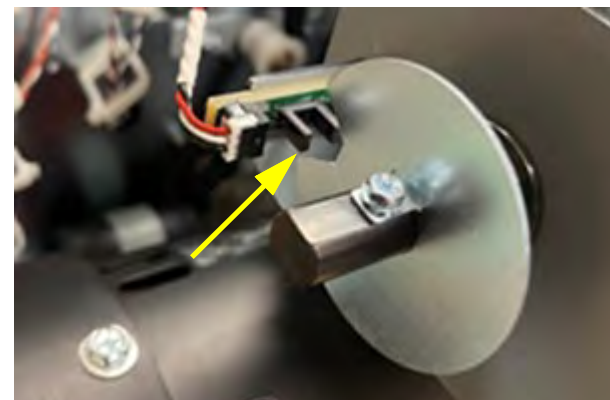

6. If the encoder disc is broken, replace it using the instructions for [Cutter Encoder on page 170](#).

7. Confirm that the belt tension has about 6-8mm deflection. If the belt is loose follow the adjustment procedure [Steering Motor Belt on page 222](#).



8. If jamming issues persists, follow the steps in [Clutch Indexing on page 229](#).

Clutch

Perform the following steps in order to troubleshoot the cutter clutch on AdvancedLam Pro. The machine should be powered off for all of these steps.

1. Check that the clutch is in the proper home position (~2 o'clock) and is not stuck in the "down" position.

If the clutch is not in the correct home position, clear the cutter jam ([Cutter Jams on page 78](#)). If necessary, modify the clutch index by following the procedure [Clutch Indexing on page 229](#).

2. Rotate the clutch belt counter-clockwise by hand.

The belt and pulley should spin freely. The blade should not move with the clutch because the clutch pawl will still be engaged.

If the pulley does not spin freely, try loosening the belt. If the clutch pulley is still bound up and will not spin, then it will need to be replaced.

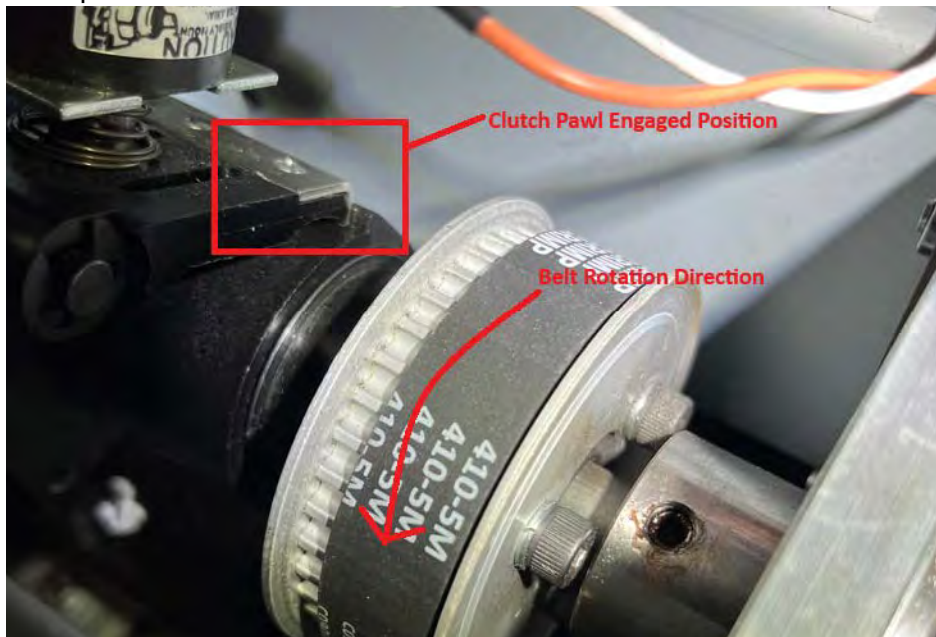

3. Check that the clutch solenoid is plugged in via the (2) spade connectors. If these are loose, the clutch will not activate properly.

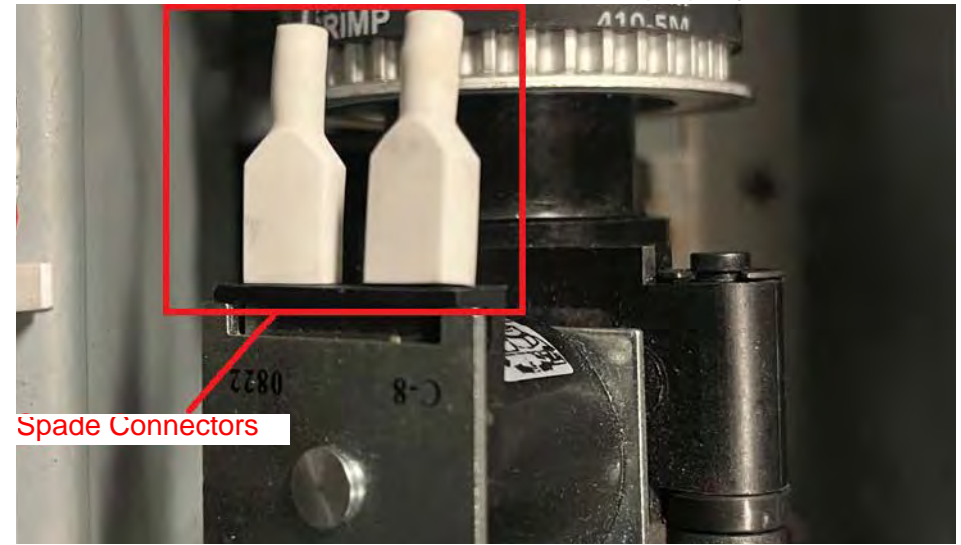

4. Check that the AC Cutter Motor is plugged in to the control board by looking for the larger two-pin connectors on the rear of the drawer and on the control board.

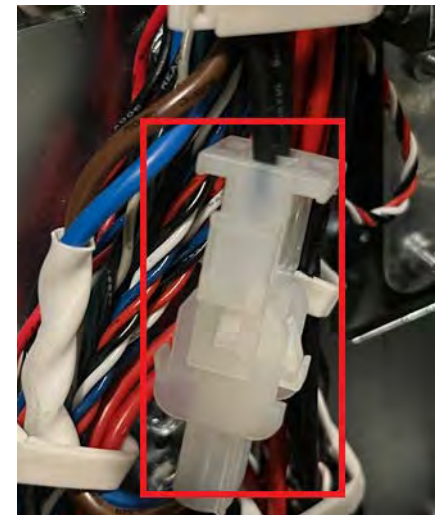

Jam Codes

Jam	Sensor	Details
JAM: CUTTER KNIFE DOWN	S23	This jam occurs when the cutter knife is not detected in the home position.
J101: PAPER AT ENTRY CLEAR AREA 1	S1	Paper detected at S1 beyond jam timeout.
J125-J126: PAPER IN BYPASS CLEAR AREA 1	S25/S26	Paper detected at S26/27 beyond jam timeout.
J127: PAPER AT EXIT CLEAR AREA 1	S27 blocked	Paper detected at S25 beyond jam timeout.
J202-203: PAPER AT LAM ENTRY CLEAR AREA 2	S2 S3	Paper detected at S2/3 beyond jam timeout.
J306-J315 PAPER IN ALIGNER CLEAR AREA 3	S6-15	Paper detected at S6-15 beyond jam timeout.
J325: NO FILM AT CUTTER	S24	No film detected at S24.
J328 ALIGN HOME TIMEOUT	S28	Align home sensor not triggered before timeout.
J408: PRESSURE ROLLER JAM CLEAR AREA 4	S8	Detects when the sheet does not leave the pressure rollers.
J422: FILM TIME OUT AT CUTTER	S22	The trail edge of the cut sheet was not detected after the cutter.
J423: NO FILM AT CUTTER	S22	The lead edge of the next sheet did not pass through the cutter successfully.
J424: UNEXPECTED TRAIL EDGE	S22	The cut edge was pulled back into the pressure rollers.
J504: PAPER IN AREA 5	S4	This jam occurs when a S4 timeout is detected.
J505: PAPER IN AREA 5	S5	This jam occurs when a S5 timeout is detected.
J514: NO SHEET AT EXIT	S4	This jam occurs when the LE of the sheet is not detected at S4 in the expected time.

J1XX Jams

Perform the following procedures if J1XX jams repeatedly occur.

1. Check to see if there is any obstruction to paper flow at the entrance of the machine.

See [Checking for Obstructions on page 76](#) in Paper Path - **Area 1 (Entrance)**

This clears the fault

Yes- Return to normal operation; **No**- Go to step 2

2. Check Sensors **S1**, **S25**, **S26** and **S27** in [Sensors S1 to S5, S25 to S27 on page 94](#).

This clears the fault

Yes- Return to normal operation; **No**- Go to step 3

3. See [Stepper Motor Checks on page 104](#) to check M1 and M8.

This clears the fault

Yes- Return to normal operation; **No**- Go to step 4

4. Check the diverter mechanism, replace the [Diverter \(SOL1 and SOL8\) on page 160](#).

This clears the fault

Yes- Return to normal operation; **No**- Go to step 5

5. Check the diverter mechanism, replace the [Diverter \(SOL1 and SOL8\) on page 160](#).

This clears the fault

Yes- Return to normal operation; **No**- Go to step 6

6. Check the nip force of rollers N1, N11, N12, N13 and N14. This can be done by:
 - Perform [Idler Roller on page 20](#) to inspect and clean the idler roller springs for these rollers.

- Perform [Drive Rollers on page 22](#) to check the drive roller condition. Clean, if necessary.
- Check the paper path drive panel positions- see [Drive Panel on page 224](#), and perform adjustments if necessary.
- Check the exit idler panel position (see [Idler Panel Magnetic Latches on page 223](#)) and perform adjustment as necessary.

This clears the fault

Yes- Return to normal operation; **No**- Escalate to next level of support.

7. Check the nip force of rollers N1, N8, N9, N10, N11, and N12. This can be done by:
 - Perform [Idler Roller on page 20](#) to inspect and clean the idler roller springs for these rollers.
 - Perform [Drive Rollers on page 22](#) to check the drive roller condition. Clean, if necessary.
 - Check the paper path drive panel positions- see [Drive Panel on page 224](#), and perform adjustments if necessary.
 - Check the exit idler panel position (see [Idler Panel Magnetic Latches on page 223](#)) and perform adjustment as necessary.

This clears the fault

Yes- Return to normal operation; **No**- Escalate to next level of support.

8. Inspect and clean the [Idler Roller on page 20](#) and [Drive Rollers on page 22](#) to inspect and clean the rollers in the bypass area.

This clears the fault

Yes- Return to normal operation; **No**- Escalate to next level of support

J2XX Jams

Do the following if the lead edge is past nip N1 but is stopped just before nip N4/5.

1. Check to see if there is any obstruction in the paper path from nip N1 to nip N3.

See [Checking for Obstructions on page 76](#) in Paper Path - **Area 2 (Entrance Idler Panel Assembly)**.

This clears the fault

Yes- Return to normal operation; **No**- Go to step 2

2. Perform the adjustment for the [Drawer Switch on page 236](#).

This clears the fault

Yes- Return to normal operation; **No**- Go to step 3

3. Check Sensors S2 and S3.

- See [Sensors S1 to S5, S25 to S27 on page 94](#) for information on S2 and S3.

This clears the fault

Yes- Return to normal operation; **No**- Go to step 4

4. Go to [Stepper Motor Checks on page 104](#) to check Motor M1 and Motor M2.

This clears the fault

Yes- Return to normal operation; **No**- Go to step 5

5. Check solenoids SOL2 and SOL3 in [Solenoids SOL2 - SOL3 on page 102](#).

This clears the fault

Yes- Return to normal operation; **No**- Go to step 6

6. Check the diverter mechanism by checking [Solenoid SOL1, SOL8 on page 101](#).

This clears the fault

Yes- Return to normal operation; **No**- Go to step 6

7. Check the nip force of rollers N2, N3. This can be done by:
 - Perform [Idler Roller on page 20](#) to inspect and clean the idler roller springs for these rollers.
 - Perform [Drive Rollers on page 22](#) to check the drive roller condition. Clean, if necessary.
 - Check the paper path drive panel positions- see [Drive Panel on page 224](#), and perform adjustments if necessary.
 - Check the entrance idler panel position (see [Idler Panel Magnetic Latches on page 223](#)) and perform adjustment as necessary.

This clears the fault

Yes- Return to normal operation; **No**- Escalate to next level of support

J3XX Jams

Do the following if the lead edge is stopped in the lamination drawer, but before the pressure rollers.

1. Check to see if there is any obstruction in the paper path.
See [Checking for Obstructions on page 76](#) in Paper Path – **Area 3 (Acceleration Roller Idler)**

This clears the fault

Yes- Return to normal operation; **No**- Go to step 2

2. Remove the film cartridge and inspect. Make sure there is nothing restricting the flow of paper.

This clears the fault

Yes- Return to normal operation; **No**- Go to step 3

3. Check to see if the lamination drawer is pushed all the way in by performing the adjustment for Lamination [Drawer Latch on page 238](#).

Yes- Return to normal operation; **No**- Go to step 4

4. Check Sensors S6, S7, S8, S9, S10.
 - Check [Sensors S6 to S10 on page 97](#)

This clears the fault

Yes- Return to normal operation; **No**- Go to step 5

5. See [Stepper Motor Checks on page 104](#) to check motors M3, M4, and M5.

This clears the fault

Yes- Return to normal operation; **No**- Go to step 6

6. See [Checking for Obstructions on page 76](#) – Area 4 (cutter module).

This clears the fault

Yes- Return to normal operation; **No**- Go to step 7

7. Check that the cutter is not stuck in the down position.

If it is, perform the [Cutter Jams on page 78](#) procedure.

If no message appeared on the screen to warn of the jammed cutter, replace the [Cutter Encoder on page 170](#).

This clears the fault

Yes- Return to normal operation;

No- Perform the troubleshooting steps for J4XX jams. If the issues persist after that, escalate to the next service level

J4XX Jams

Follow these procedures when the first sheet jam is occurring in lamination drawer after S6-S10.

Message Based Troubleshooting

J408: Pressure Roller Jam

This message is displayed when the sheet did not leave the steering module in the expected amount of time.

If the sheet has stopped in the pressure roller, partially laminated with the lead edge undamaged and check the following in order until a the issue is resolved.

1. Inspect the pressure roller gears for damage or obstructions
2. Check that the M8 belt tension is correct following the adjustment procedure [Steering Motor Belt on page 222](#).
3. Check that M8 functions following the procedure for [Stepper Motor Checks on page 104](#).
4. Check Sensors S6-S10 by performing the procedure in [Sensors S6 to S10 on page 97](#).
5. Inspect the [Cartridge Frame on page 49](#) for damage.
Damage to the cartridge can allow the cartridge to touch the rollers resulting in motor stalls.
Inspect the lamination roll for damage as described in the user manual.
6. Inspect the [Cartridge Rail on page 47](#).
If the rail is loose or damaged, it can allow the cartridge to touch the rollers resulting in motor stalls.
7. Try using different cartridge and refill.
NOTE: A refill may have insufficient friction against the upper and lower spools which will cause the film to stick to the frame after each jog.
8. Perform the troubleshooting procedures for [J3XX Jams on page 84](#).
9. If the issue persists, perform the troubleshooting steps for [J422: Film Timeout at Cutter on page 85](#).

J422: Film Timeout at Cutter

This jam occurs when the trail edge of the cut sheet is not detected leaving the cutter.

1. If the cutter is stuck in the down position, go to the procedure [Jam: Cutter Knife Down on page 88](#).
2. Check S22 by following instructions on [Sensors S1 to S5, S25 to S27 on page 94](#).
3. Check Area 5 for any obstructions in the paper path.
4. Inspect the sheet that had its trail edge cut.
 - If the trail edge failed to cut, or the cut was uneven, go to the [Incomplete Cuts on page 59](#).
5. If there is no indication the cutter attempted to cut the film:
 - Check Sensors S1b and S24 in the [Sensor 1B - Cutter on page 96](#) and [Sensors S1 to S5, S25 to S27 on page 94](#).
 - Check that the cutter still functions by performing a Film Proof function in the user menu.
 - If the AC motor cutter failed to turn on, perform the steps in [AC Motor Check on page 106](#).
 - If the AC motor turned on, but the clutch did not activate perform the troubleshooting procedure for the [Sensor Checks on page 91](#).
6. Check M7 and M9 following the procedure for [Stepper Motor Checks on page 104](#).
7. Perform the adjustment for [Trim Diverter Solenoid \(SOL 8\) on page 211](#) to check that the diverter is set correctly.
If the Limiter is set too high, M9 stalls can occur, resulting in J422s.
8. Check that the lamination drawer latch is set properly following [Lamination Drawer on page 235](#).
9. Escalate to the next level of support.

J423: No Film at Cutter

This jam occurs when the lead edge of the sheet does not exit the cutter after a cut is performed.

1. If the cutter is stuck in the down position, go to the [Jam: Cutter Knife Down on page 88](#).
2. Clean the blade following the Blade cleaning procedure.
3. Rotate the cut stick to a new face, and clean the surface.
4. Check the cutter area for debris. Small slivers of film can get caught in the cutter areas after jams which cause issues in later cuts.
5. Clean the [Pressure Roller on page 24](#).
6. Check S22 following the procedure [Sensors S1 to S5, S25 to S27 on page 94](#).
7. Check that the clutch is properly indexed following the steps in [Clutch Indexing on page 229](#).
8. Follow the log saving procedure and check the log file for the presence of a E423 error,

If E423 error is listed in the log file, refer to [E423: Unexpected Cut on page 68](#).
9. Check that the M8 belt tension is correct following the M8 belt tension adjustment in [Steering Motor Belt on page 222](#).
10. Check that M8 motor functions following [Stepper Motor Checks on page 104](#).
11. Check that the locking mechanism springs are set correctly following the adjustment [Locking Mechanism Springs on page 237](#).
12. Inspect the cartridge for damage following [Cartridge Frame on page 49](#).
13. Escalate to the next level of support.

J424: Unexpected Trail Edge

This jam occurs when a trail edge is detected at S22 when one is not expected. This stop occurs to prevent the film from being pulled back into the pressure rollers causing a wrap.

1. Inspect the cutter outfeed baffle area for debris following the [Cutter Out-feed Baffle on page 35](#) procedure.
2. Check S22 following [Sensors S1 to S5, S25 to S27 on page 94](#).
3. Perform the [Trim Diverter Solenoid \(SOL 8\) on page 211](#) adjustment to check that the diverter is set correctly. If the Limiter is set too low, sheets exiting the cutter can hit it, causing J424s
4. Check the lamination drawer position following the steps in [Lamination Drawer on page 235](#).
5. Escalate to the next level of support.

J5xx Jams

J514: No Sheet at Exit

This jam occurs when the lead edge of a short edge feed sheet is not detected at S4 in the expected amount of time. This is meant to prevent the film from wrapping on the roller.

1. Check S4 following the procedure for [Sensors S1 to S5, S25 to S27 on page 94](#).
2. Perform the steps outlined in [J424:Unexpected Trail Edge on page 86](#).
3. Return here and carry on with the steps below if the problem persists.

Do the following if the first jammed sheet's trail edge is past N6 and N7.

1. Check to see if there is any obstruction in the paper path from N4 and N5.
[Checking for Obstructions on page 76](#).

This clears the fault

Yes- Return to normal operation; **No**- Go to step 2

2. See [Sensors S1 to S5, S25 to S27 on page 94](#) to check Sensors S4, and S5.

This clears the fault

Yes- Return to normal operation; **No**- Go to step 3

3. See [Sensors S6 to S10 on page 97](#).

This clears the fault

Yes- Return to normal operation; **No**- Go to step 4

4. See [Stepper Motor Checks on page 104](#) to check Motors M7 and M9.

This clears the fault

Yes- Return to normal operation; **No**- Go to step 5

5. Check the nip forces of roller N6 and N7. This can be done by:
 - Perform [Idler Roller on page 20](#) to inspect and clean the idler roller springs for these rollers.
 - Perform [Drive Rollers on page 22](#) to check the drive roller condition. Clean, if necessary.
 - Check the paper path drive panel positions- see [Drive Panel on page 224](#), and perform adjustments if necessary.
 - Check the exit idler panel position (see [Idler Panel Magnetic Latches on page 223](#)) and perform adjustment as necessary.

This clears the fault

Yes- Return to normal operation; **No**- Escalate to next level of support

Jam: Cutter Knife Down

This message occurs when the cutter knife does not return to the home position after cutting.

1. Unjam the cutter following the procedure [Cutter Jams on page 78](#).
2. Check that the cutter encoder is functioning properly following the [Cutter Encoder on page 170](#) repair procedure.
3. Check S23, following instructions in [Sensors on page 11](#), to confirm that it is working.
4. Check that the clutch is properly indexed following [Clutch Indexing on page 229](#).
5. Check the cutter motor belt tension is set properly following the adjustment procedure [Motor Belt Tension on page 228](#).
6. Check the connecting rod length and spring settings following [Connecting Rod Length on page 231](#) and [Connecting Rod Spring on page 233](#).
7. Perform the [AC Motor Check on page 106](#) procedure.
8. Check that the wall supply is receiving the correct voltage.
The wall should supply between 104V to 127V for 115V machines and between 207V and 253V for 230V machines.
9. Perform the [No AC Power on page 71](#) procedure.
10. Replace the cutter motor following the procedure [Cutter Module on page 163](#).
11. Escalate to the next level of support.

Resetting the Film Cartridge

Follow this procedure after the laminator has experienced a bad jam.

Clear any jams before executing this procedure.

If the film spools are not aligned, the film will either look crumpled or the two sides will not be mated properly.



1. Use a scissors to cut below the point where the top and bottom spools come together and dispose of the damaged film.

With the top spool and bottom spool now independent of each other the two pieces of film should not be attached to each other anymore



2. Find the edge of the film on the bottom spool and fold it backwards so that the adhesive side of it is facing upwards.

The film should be resting on the spool.

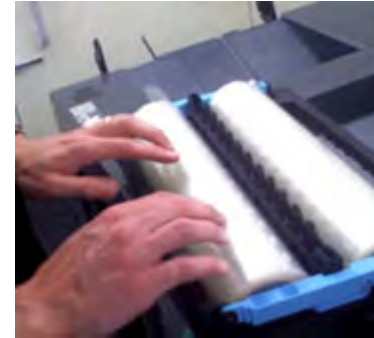

3. Hold the bottom spool film in place with one hand and with your other hand grab the edge of film from the top spool.
4. Pull the top film downwards until it is aligned with the bottom spool and then press both pieces of film together.



IMPORTANT: The edges of the two film layers must be lined up on the left and right. If they are not, the film will not run correctly in the machine.

5. Use a scissors to cut the attached film so that only 1-2 inches are pressed together.

If the overlap is more than this the cartridge will not be able to be inserted back inside the machine.

6. Insert the film cartridge back into the machine.

After inserting the cartridge back into the machine, it may be necessary to follow the next steps if you are unable to get the film to feed through

the baffle when using the LCD. This is particularly true if you weren't able to place the two layers of film together evenly in the previous page (see example below).



7. Ensure the machine is off and the drawer is pulled out.
8. Slowly turn the lamination knob counter-clockwise to begin to feed the film through the rollers.

The film will most likely not be able to exit the cutter outfeed baffle smoothly. Get at least one section of the film to pass through enough to grab with your fingers. If none of the film can make it through, repeat steps 1-6, from the previous page, until the film is reset more smoothly.

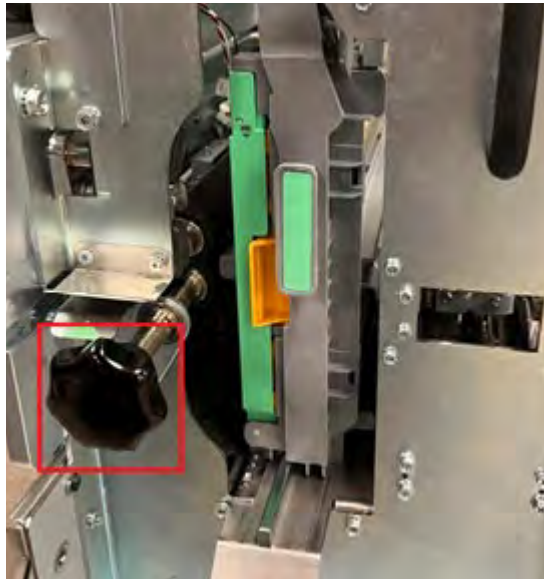

9. Once a small section of film is able to make it out of the baffle, stop turning the knob. Open the locking mechanism to the open position.
10. Grab the piece of film that is protruding and tug the film outwards approximately 1-2 feet until most of the uneven film is outside the baffle and smooth film is starting to appear.



11. Close the locking mechanism handle and cut the excess film using a small knife.



12. Push the drawer in and close the machine door.
13. Test run film through the machine using the user functions menu.

Sensor Checks

This procedure is for all sensors, details for which can be found on succeeding pages.

1. Perform steps in [User Functions on page 11](#). Check to make sure all sensors should show “0” on the LCD when uncovered and “1” when covered.

If any sensor shows “1” when uncovered, clean that sensor. Also check if there is any obstacle in the sensor window.

All sensors show “0” when uncovered and “1” when covered

Yes- Return to the RTP that directed you here.; **No**- Go to step 2

2. Check the connections to the faulty sensor(s).

See the table [Sensor Cables on page 93](#) for cable numbers.

- Remove [Rear Cover on page 110](#). Check the connection at the header in the cutter frame and the main control board. See [Wiring on page 263](#) for the location of the Connector.
- Remove the cutter module. Check the connection from the sensor board to the header in the laminator frame. S18 to 21 do not have headers, so inspect the connection at sensor board and main control board.

All the connections are made securely

Yes- Go to step 3; **No**- Make the connection and return to normal operation.

3. Light from sensor components can be viewed with a cell phone camera, if the sensor is working you will be able to see a bright light. Alternately a small mirror can be used.



WARNING: Sensor emits High Intensity narrow angle Infrared beam (940nm). It is invisible to naked eye, avoid looking directly at the sensor when the machine is powered ON.

- If there is no light from any sensor on that particular board (S6-S10; S11-S15; S16-17; S18-19; S20-21):
 - Replace cable from the sensor board to the laminator frame first. If that does not solve the issue, replace cable from frame to main control board. See the table [Sensor Cables on page 93](#) for cable numbers.
 - Replace the faulty Sensor Board. See [Paper Path Sensors on page 150](#)).
- On the same board, if there is light from one sensor and there is no light from another sensor:
 - Replace the faulty sensor board. See [Paper Path Sensors on page 150](#)).
 - Replace the sensor cable from the sensor board to laminator frame first. If that does not solve the issue, Replace the sensor cable from the frame to main control board. See the table [Sensor Cables on page 93](#) for cable numbers.

There is a bright light from all the sensors

Yes- Go to step 4; **No**- Replace the faulty component and resume normal operation

4. Replace the faulty sensor board. See [Paper Path Sensors on page 150](#)).

This clears the fault

Yes- Resume normal operation; **No**- Go to step 5

5. Replace the faulty sensor cable

See the table [Sensor Cables on page 93](#) for cable numbers.

This clears the fault

Yes- Resume normal operation; **No**- Go to step 6

6. Perform the procedure to upgrade the firmware found here, [Firmware Update / Save Logs on page 14](#).

This clears the fault

Yes- Resume normal operation; **No**- Go to step 7

7. Replace the [Main Control Board on page 203](#).

This clears the fault

Yes- Resume normal operation; **No**- Escalate to next level of support.

Sensor Cables

Sensor	Description	Cable #	Header	Interim Cable #	Control Board Connector	Other Info
S1	Entrance Sensor, S1	7725551	-	-	J21	Shares cables with S25, S26
S2	Entrance Sensor, Top	7725552	-	-	J22	Shares cables with S2,S3, S4, S5
S3	Entrance Sensor, Bottom	7725552	-	-	J22	Shares cables with S2,S3, S4, S5
S4	Exit Sensor, Bottom	7725552	-	-	J22	Shares cables with S2,S3, S4, S5
S5	Exit Sensor, Top	7725552	-	-	J22	Shares cables with S2,S3, S4, S5
S6	Skew Sensor Board	7725573	Header	7725553	J23	
S7	Skew Sensor Board	7725573	Header	7725553	J23	
S8	Skew Sensor Board	7725573	Header	7725553	J23	
S9	Skew Sensor Board	7725573	Header	7725553	J23	
S10	Skew Sensor Board	7725573	Header	7725553	J23	
S11	Alignment Sensor Board	7725574	Header	7725555	J24	
S12	Alignment Sensor Board	7725574	Header	7725555	J24	
S13	Alignment Sensor Board	7725574	Header	7725555	J24	
S14	Alignment Sensor Board	7725574	Header	7725555	J24	
S15	Alignment Sensor Board	7725574	Header	7725555	J24	
S22	Post Cut Sensor	7725155	Header	7725557	J28	
S23	Knife Home Sensor	7725155	Header	7725557	J28	
S24	Film Present Sensor	7725155	Header	7725557	J28	
S25	Bypass Sensor	7725551	-	-	J21	Shares cable with S1, S26
S26	Bypass Sensor	7725551	-	-	J21	Shares cable with S1, S26
S28	Align Home Sensor	7725575	Header	7725554	J25	
S29	Trim Tray Level Sensor - Emitter/ Receiver	7725152	Header	7725583 (Emitter) 7725583 (Receiver)	J27	
S1B	Cut Sensor	7725583 (Emitter) 7725565 (Receiver)	-	-	J29	

Sensors S1 to S5, S25 to S27

1. Ensure that the front door is properly closed.

An interrupted interlock connection can trigger sensor paper jam codes.

2. Perform [User Functions on page 11](#). Check to make sure all sensors show “0” on the UI when uncovered and “1” when covered.

If any sensor shows “1” when uncovered, clean that sensor. Also check if there any obstacle in the sensor window.

Sensors 1, 25, 26, and 27 are under the upper bypass panel.

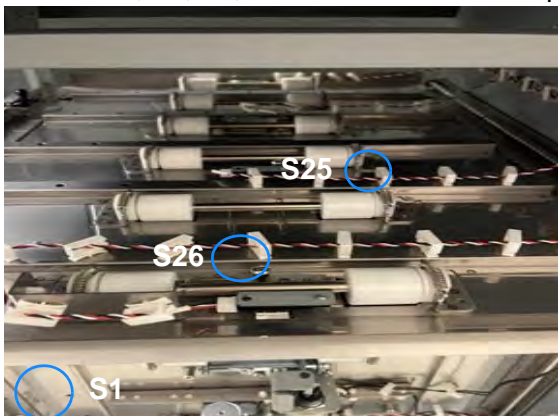

Sensors 2, 3 and 4 are on the entrance idler panel.

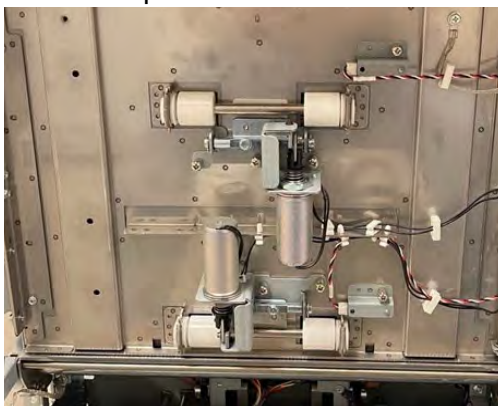

All sensors show “0” when uncovered and “1” when covered

Yes- Return the machine to normal operation; **No-** Go to step 3

3. Make sure the sensor wire is connected securely at the sensor and at the main control board. Remove the [Rear Cover on page 110](#) to gain access to the connector at the control board.

See the table [Sensor Cables on page 93](#) for cable numbers.

See [Wiring on page 263](#) for details on connection at the sensor(s).

All the connections are made securely

Yes- Go to step 4; **No-** Make the connection and return to normal operation.

4. Replace the sensor with a new one (alternatively, swap the sensor in the faulty position with a sensor from a different good position to check if it is a bad sensor). See [Paper Path Sensors on page 150](#) for replacement.

Replacing the sensor corrects the issue

Yes- Use the new sensor and return to normal operation; **No-** Go to step 5

5. [Undock the Laminator on page 110](#) and visually inspect the cable from the sensor all the way to the control board. Replace the cable if it is damaged. Additionally, check the continuity of each wire.

See the table [Sensor Cables on page 93](#) for cable numbers.

Sensor cable looks okay

Yes- Go to step 6; **No-** Replace the sensor cable.

6. Upgrade the firmware (see [Firmware Update / Save Logs on page 14](#)).

Re-flashing firmware clears the fault

Yes- Resume normal operation; **No-** Go to step 7

7. Replace the sensor cable.
 - [Undock the Laminator on page 110.](#)
 - Remove the faulty cable from the sensor by releasing the required cable clamps.
 - Replace with a new cable.See the table [Sensor Cables on page 93](#) for cable numbers.

Replacing the sensor cable corrects the issue

Yes- Resume normal operation; **No**- Go to step 8

8. Replace the [Main Control Board on page 203.](#)

This clears the fault

Yes- Resume normal operation; **No**- Escalate to next level of support

Sensor 1B - Cutter

To locate the sensor, do the following:

LCD shows “0” when unblocked and “1” when blocked

If the cutter sensor, S29, is always reading as blocked perform the following steps in order until the issue is resolved. If the sensor is reading unblocked, start at step 3.

1. Check that the emitter and receiver are both connected.
2. Check that they are both connected to J5 on the breakout board and J30 on the control board.
3. Check the voltage and resistance measurements for S1B by following the adjustment for [S1B - Cutter on page 239](#). If you cannot resolve the issue, return here.
4. Pull the lamination drawer out and ensure the sensor bracket is connected tightly to the baffle beneath it via (2) nuts. Check that the bracket is not bent or bowed in the middle, which could cause the sensors to be mounting position to be incorrect. If this is the case, the bracket will need to be replaced.

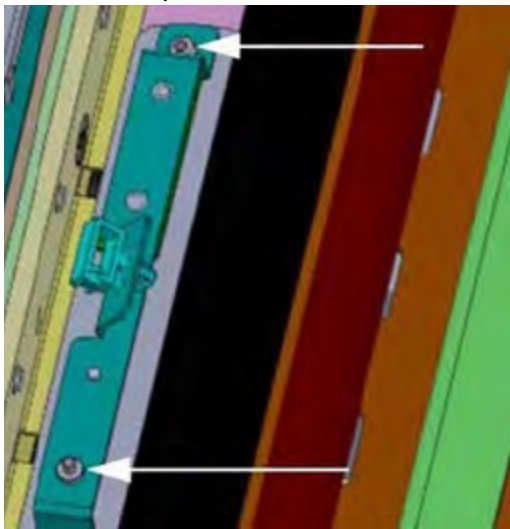

5. Replace the [Trim Level Emitter on page 173](#) and [Trim Level Receiver on page 173](#).
6. Check all of the connections to the breakout board. If it is plugged in and still not reading the correct voltage, replace the [Breakout Board on page 205](#).
7. Replace the [Main Control Board on page 203](#).

Sensors S6 to S10

Sensors S6, S7, S8, S9, S10

To access the sensors do the following:

- Open front door.
- Remove the cartridge.
- Pull out the lamination drawer.

Sensors are on the skew sensor board.

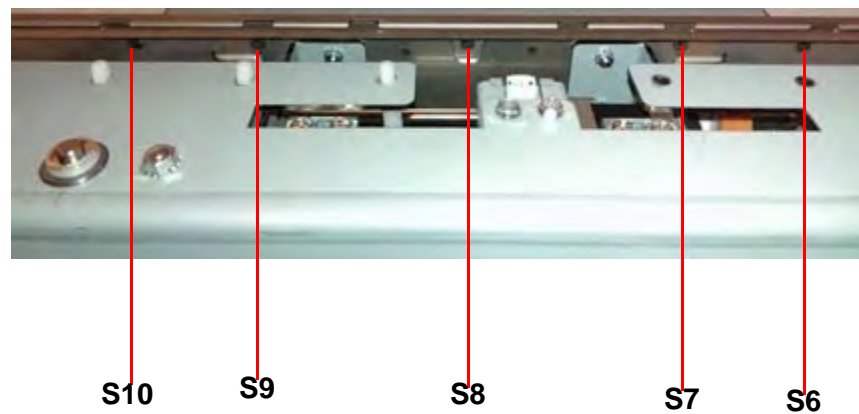

Sensor S11 to S15

To access the sensors do the following:

- Open front door.
- Remove the cartridge.
- Pull out the lamination drawer.

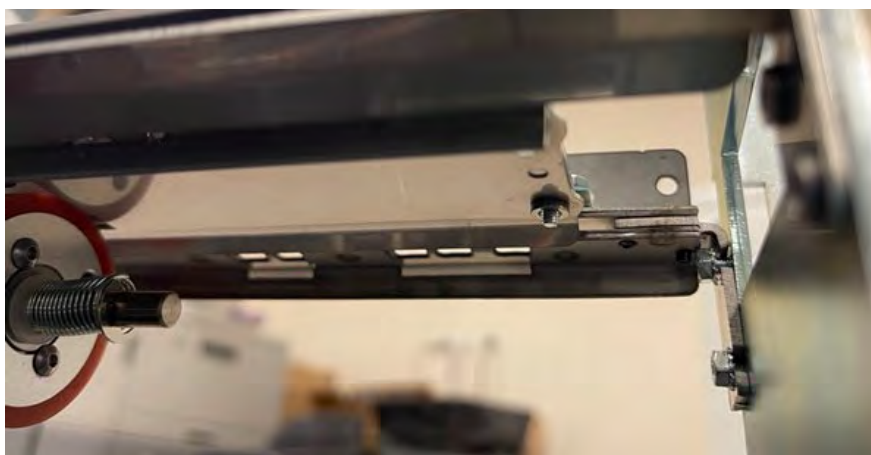
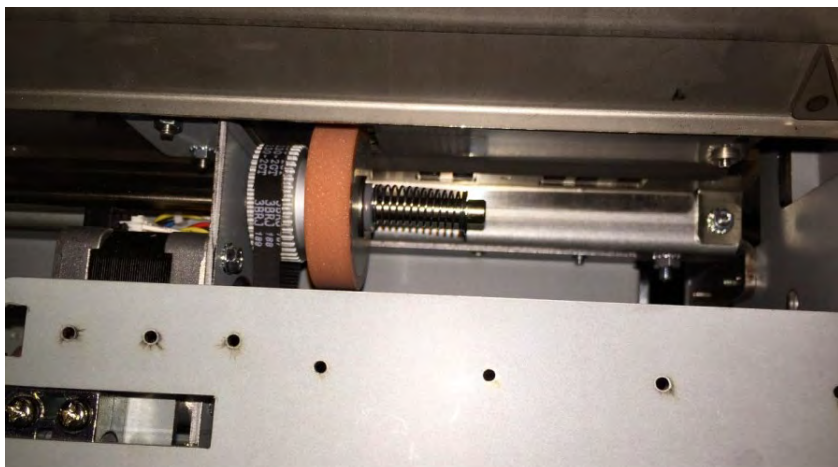

Sensor S28 Align Home Sensor

To locate the sensor, do the following:

- Open the front door.
- To uncover this sensor, slide the alignment carriage towards the front of the machine.
- To cover this sensor, slide the alignment carriage towards the rear of the machine.

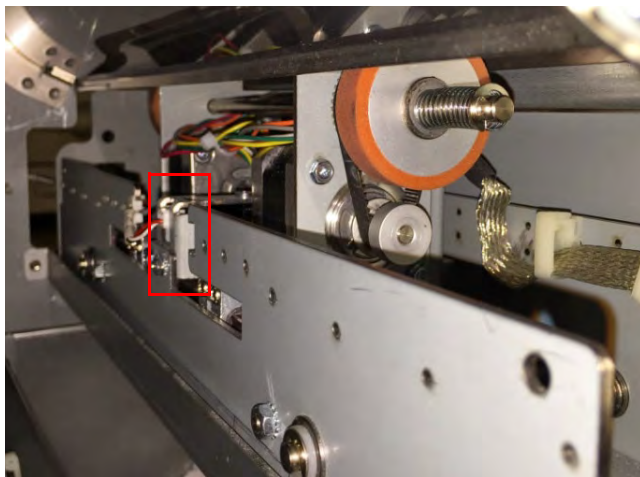

1. Perform the [User Functions on page 11](#) procedure. Check to make sure the sensor shows “1” on the LCD when the Alignment carriage flag blocks the sensor and “0” when the Alignment carriage flag unblocks the sensor.

LCD shows “0” when unblocked and “1” when blocked

Yes- Return to the RTP that directed you here.; **No-** Go to step 2

2. Make sure the sensor wire is connected securely at the header in the cutter module frame and the main control board.

See the table [Sensor Cables on page 93](#) for cable numbers.

See [Wiring on page 263](#) for the location of the connector.

Connection is secure at the laminator frame and control board.

Yes- Go to step 3; **No-** Make the connection and resume normal operation

3. With the front door open, check if the sensor wire is connected securely at the sensor and the cutter module frame on the inside.

Connection is secure at both ends

Yes- Go to step 4; **No-** Make the connection and resume normal operation

4. Replace the align home sensor, see [Paper Path Sensors on page 150](#).

This clears the fault

Yes- Resume normal operation; **No-** Go to step 5

5. Visually inspect the sensor cable 7715519 from sensor to laminator frame header; 7715457. Then from laminator frame header to control board. If the cable is damaged, replace the cable. To closely inspect the sensor cable from sensor to header, it is recommended to [Undock the Laminator on page 110](#).

Cable appears to be damaged

Yes- go to step 7 or 8; **No-** Go to step 6

6. See [Firmware Update / Save Logs on page 14](#) to upgrade the firmware.

This clears the fault

Yes- Resume normal operation; **No-** Go to step 7

7. Replace the sensor cable from align home sensor to header; refer to [Wiring on page 263](#).

This clears the fault

Yes- Resume normal operation; **No-** Go to step 8

8. Replace the cable from header to main control board, refer to [Wiring on page 263](#).

This clears the fault

Yes- Resume normal operation; **No**- Go to step 9

9. Replace the [Main Control Board on page 203](#).

This clears the fault

Yes- Resume normal operation; **No**- Escalate to next level of support

Sensor S29 Trim Tray

To locate the sensor, do the following:

LCD shows “0” when unblocked and “1” when blocked

If the trim tray sensor, S29, is always reading as blocked perform the following steps in order until the issue is resolved. If the sensor is reading unblocked, start at step 3.

1. Check that the emitter and receiver are both connected.
2. Check that they are both connected to J5 on the breakout board and J21 on the control board
3. With the power off, check the resistance across TP-29 and TP-29R on the break out board using a multimeter.

It should be set to a voltage reading of 1.3V, which requires an ohm reading from 350-500 ohms. If it is not, adjust the screw on the potentiometer next to the test points until the correct resistance is achieved.

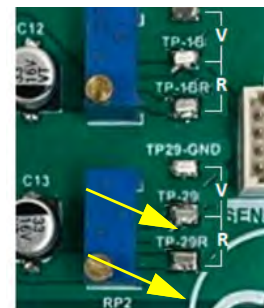

4. With the power on and door closed, check the voltage across TP29-GND and TP-29.

It should read >4.5V. Move on if this is correct. If it does not read >4.5V, check all the connections to the breakout board.

5. Replace the emitter and receiver.
6. Replace the [Main Control Board on page 203](#).

Solenoid Checks

Solenoid SOL1, SOL8

Solenoid SOL1 is the diverter solenoid- mechanical adjustment is covered in [Diverter Solenoid \(SOL1\) on page 210](#).

1. Open the front the door and insert an interlock cheater into the door interlock switch SW4.



WARNING: Moving Parts, keep hands clear of nips and the belts when the interlock cheater is inserted.

2. See [Solenoids on page 12](#) to activate and deactivate SOL1 or SOL8. The diverter gate should rise and fall when SOL1 or SOL8 is cycled.

Diverter gate rises and falls when SOL1 or SOL8 is cycled

Yes- Return to the RTP that directed you here; **No-** Go to step 3 and choose the appropriate condition

3. If SOL1 or SOL8 does not function, do the following:
 - Remove the [Rear Cover on page 110](#).
 - Check the cable from the solenoid to the in-line header. This cable is part of the solenoid body.
 - Check cable 7715466 that connects the in-line header to the main control board.
 - Replace the solenoid ([Diverter \(SOL1 and SOL8\) on page 160](#)), as needed.

If the solenoid functions, do the below steps:

- Go to [Diverter Solenoid \(SOL1\) on page 210](#) or [Trim Diverter Solenoid \(SOL 8\) on page 211](#) to perform an adjustment, if necessary.

This clears the fault

Yes- Return to normal operation; **No-** Go to step 4

4. See [Firmware Update / Save Logs on page 14](#) to upgrade the firmware.

This clears the fault

Yes- Return to normal operation; **No-** Go to step 5

5. Replace [Diverter \(SOL1 and SOL8\) on page 160](#).

This clears the fault

Yes- Return to normal operation; **No-** Go to step 6

6. Replace the [Main Control Board on page 203](#).

This clears the fault

Yes- Return to normal operation; **No-** Escalate to next level of support

Solenoid SOL6

Solenoid SOL6 is the cutter clutch, see:

- [Clutch on page 80](#).

Solenoids SOL2 - SOL3

1. Open the front the door and insert an interlock cheater into the door interlock switch SW4.



WARNING: Moving Parts, keep hands clear of nips and the belts when the Interlock Cheater is inserted.

2. Do the steps for [Solenoids on page 12](#) to activate and deactivate the affected solenoid.

When the solenoid is not activated, the idler roller should be able to rotate freely, and in turn drive the drive roller.

When the solenoid is fully activated, the idler roller should completely lift off and not be able to drive the drive roller.

NOTE: Disengaging solenoid modules need to be Replaced every 5 million cycles.

To check the holding force of the solenoid, go to step 3

If the solenoid does not actuate, go to step 4

Alternate solenoid inspection method:

Mark a line on the idler roller shaft, as shown in the picture.



Motor running + Solenoid actuated = Line not visible
 Motor running + Solenoid not actuated = Line visible

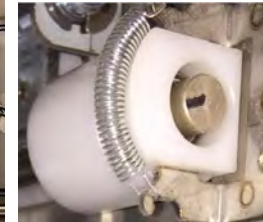

Picture shows Motor running and solenoid actuated.

From the service mode solenoid can be actuated using GP 6.2.6 Solenoids Procedure, and the corresponding drive roller rotated manually to check this.

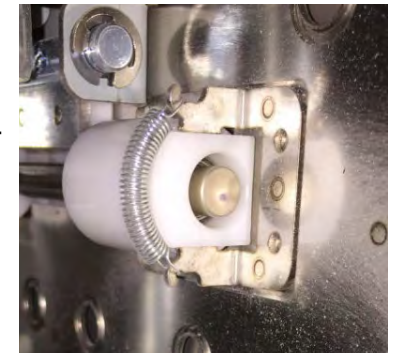

3. Do the following to check the holding force of the Solenoid:
 - Activate a good solenoid and the solenoid in question (bad solenoid).
 - Try to push the plunger of the solenoid away from the body of the solenoid. Both solenoids should have approximately the same holding force. If the bad solenoid's holding force is low, follow instructions in [Solenoids on page 159](#) to replace.

This clears the fault

Yes- Return to normal operation; **No**- Go to step 6

4. If the solenoid does not activate at all, inspect the cables from solenoid to header to control board- See [Wiring on page 263](#).

The solenoid cables look okay

Yes- Go to step 5; **No**- Replace the cable

5. Follow instructions in [Solenoids on page 159](#) to replace.

This clears the fault

Yes- Return to normal operation; **No**- Go to step 6

6. Do a firmware upgrade following the steps in [Firmware Update / Save Logs on page 14](#).

This clears the fault

Yes- Return to normal operation; **No**- Go to step 7

7. Replace the cable from header to the main control for the solenoid in question. 7715466 or 7715467, see [Wiring on page 263](#).

This clears the fault

Yes- Return to normal operation; **No**- Go to step 8

8. Replace the [Main Control Board on page 203](#).

This clears the fault

Yes- Return to normal operation; **No**- Escalate to next level of support

Stepper Motor Checks

To troubleshoot the stepper motors, follow these steps.

1. Open the front the door and insert an interlock cheater into the door interlock Switch SW4.



WARNING: Moving Parts, keep hands clear of nips and the belts when the Interlock Cheater is inserted.

2. For motors M1, M2, M3, M4, M6, M7, and M8; see [Motors on page 11](#) to check that the corresponding nip rollers turn (check drive and idler rollers, for the identifying the motors).

For Motor M5, do [Function Tests on page 12](#) (Aligner Test).

Table below identifies the nip rollers driven by the corresponding motors:

Motor	Nip rollers
M1	N2, N3 and N4
M2	N5
M3	N6- Front side steering roller
M4	N7- Rear side steering roller
M5	Alignment Carriage
M6	N8, N9
M7	N10
M8	N1, N11, N12, N13, N14

3. Remove the [Rear Cover on page 110](#).

4. If you are troubleshooting M3 or M4 or M5, do the step below; for other motors directly go to step 5.

M3- Make sure the connector for M3 is inserted into the header at the back of the cutter module.

M4- Make sure the connector for M3 is inserted into the header at the back of the cutter module.

M5- Make sure the connector from M5 stepper motor is inserted into the driver board for motor M5.

All the connectors are securely connected.

Yes- Go to step 5; **No-** Make the connection and resume operation

5. For the motor in question, make sure three connectors at the stepper driver board (J1, J2 and J3) and the below two connectors at the main control board are inserted firmly.

- J17 and J16 for M3, M4 and M5
- J17 and J15 for M6, M7 and M8
- J17 and J14 for M1 and M2

All the connectors are securely connected.

Yes- Go to step 6; **No-** Make the connection and resume operation

6. Inspect the timing belt for the correspond motor drive, see [Paper Path Timing Belt on page 44](#). Follow the procedure to inspect the belts and replace if necessary ([Timing Belts on page 144](#)).

NOTE: If the timing belt of motor M5 is damaged, see [Alignment Carriage Sub-Assy on page 177](#) to replace the entire sub-assembly.

For M5 alignment stepper motor, inspect the open ended belt in the alignment carriage sub-assembly. If it is damaged, replace the [Alignment Carriage Sub-Assy on page 177](#).

All timing belts are okay

Yes- Go to step 7; **No-** Replace the faulty belt and resume operation

7. Check the tightness of the set screw of pulley on the stepper motor shaft. Also check the set screws/coiled spring pins for all the pulleys that are driven by the stepper motor in question.

All the set screws are secured tightly

Yes- Go to step 8; **No**- Tighten the loose set screw and resume operation

8. For the motor in question, check the DIP switch settings for the corresponding Driver Board (see [M1-7, M9 Motor Driver \(Stepper Board\) on page 157](#)).

All the DIP switch setting are correct

Yes- Go to step 9; **No**- Correct the DIP switch and resume operation.

9. Check if there is power to the driver board. LED 1 on the board should be lit.
- If LED 1 is lit, it means there is 24V DC power to the driver board from the main control board.
 - If LED 2 is lit, it means there is a fault with either the driver board or the stepper motor.

Continue to step 10

10. Check the cable connecting the stepper motor to the driver board (hard-wired to motor); and two cables connecting the driver board to the main control board
- 7715477 and 7715470 for M3, M4 and M5
 - 7715477 and 7715473 for M6, M7 and M8
 - 7715477 and 7715468 for M1 and M2

The cables are not damaged

Yes- Go to step 11; **No**- Replace the faulty cable and resume normal operation

11. See [Firmware Update / Save Logs on page 14](#) to upgrade the firmware.

This clears the fault

Yes- Resume normal operation; **No**- Go to step 12

12. Replace the driver board for the faulty motor, with DIP switch set correctly for the position you are replacing- [M1-7, M9 Motor Driver \(Stepper Board\) on page 157](#).

This clears the fault

Yes- Resume normal operation; **No**- Go to step 13

13. Replace the faulty stepper motor
- For M1, M2, M6, M7 and M8 see [Stepper and Mount Assembly on page 149](#)
 - For M3 and M4 see [Steering Stepper Motor on page 180](#)
 - For M5 see [Steering Module on page 174](#)

This clears the fault

Yes- Resume normal operation; **No**- Go to step 14

14. Replace the cables from control board to driver board.
- If LED1 of any of the driver board is not lit, replace 7715477
- For other issues, Replace one of the below cables:
- 7715470 for M3, M4 and M5
 - 7715473 for M6, M7 and M8
 - 7715468 for M1 and M2.

This clears the fault

Yes- Resume normal operation; **No**- Go to step 15

15. Replace the [Main Control Board on page 203](#).

This clears the fault

Yes- Resume normal operation; **No**- Escalate to next level of support

AC Motor Check

If the AC motor that drives the cutter does not function, perform these troubleshooting steps.

1. Check that the cutter is not jammed.
 - If it is, perform the [Jam: Cutter Knife Down on page 88](#) clearing procedure.
 - If the cutter continues to jam, go to step 6.
2. Go to the User Functions menu on the LCD and run the “Cycle Cutter” function.
 - If the motor does not power on, continue to step 3.
 - If the motor powers on, but does not complete a cut rotation, go to step 6.
3. Confirm the motor is plugged in, the motor cable is plugged into the main control board at J20, and the breakout board at J1.
4. Use a multimeter to measure the voltage enter the main control board at J20. This value should match the voltage measured at the wall outlet.
 - If this does not, measure the voltage at J1 of the breakout board (7725522).
 - If the voltage out does not match the wall outlet, replace the breakout board (7725522).
 - If the voltage in does not match the wall outlet, replace the cable (7725569).
5. Use a multimeter to check the wire continuity from the AC motor to where it connects to the main control board at J36.
 - If there is no continuity, identify where the connection is broken and replace that wire.
6. Check wall voltage.
 - The wall voltage should measure 104V-127V for 115V machines and 207V-253V for 230V machines. If the voltage is out of this range, resolve this before continuing troubleshooting.
7. Check the belt tension following the [Motor Belt Tension on page 228](#) and tighten the belt if loose.
8. Check if the pulley on the clutch can rotate freely by hand when the clutch is in the disengaged position.
 - Replace the clutch if it is difficult to rotate following [Clutch on page 164](#).
9. If all of the above actions have been executed and the AC motor still does not function, escalate to next level of support.

Repair Procedures

The repair procedures are organized by different major components. Click on the [blue](#) links, shown below, to be taken to the relevant section or repair procedure.

Precautions	109
Tools Needed	109
Work Environment	109
Pre-Requisites	110
Rear Cover	110
Undock the Laminator	110
Dock the Laminator	111
Cabinet	112
Top Cover	112
Front Door	113
Bottom Hinge Bracket	113
Panel Open Magnet	114
Door Latch.....	115
Interlock Switch	116
Upstream Rear Side Cover	117
Left Side Cover	117
Downstream Rear Side Cover	118
LCD Display	119
Casters	120
Docking Brackets	120
Exhaust Fan	121

Paper Path	123
Lower Entrance Panel	123
Lower Exit Panel	124
Inner Entrance Panel	125
Entrance Idler Panel	126
Entrance Drive Panel	128
Exit Idler Panel	129
Drive Exit Panel	131
Hinged Exit Panel	133
Upper Bypass Panel	134
Lower Bypass Panel	135
Bypass Diverter	136
Panel Close Magnet	137
Idler Roller	138
Idler Panel Mount Bracket	139
Flange Ball Bearing	140
Snap-in Bearing	141
Bearing Housing	142
Drive Idler Roller	143
Timing Pulley	143
Timing Belts	144
132T Timing Belt.....	144
166T Timing Belt.....	145
539T Timing Belt.....	145
197T Timing Belt.....	146
162T Timing Belt.....	146
Drive Roller Assembly	147
Stepper and Mount Assembly	149
Paper Path Sensors	150
Sensors: S1, S25, S26 and S27	151
Sensors: S1B, S22 and S24	151
Sensors: S2, S3, S4, S5	153
Sensor S28	154
Sensors 6 through 10.....	155
Sensors 11 through 15.....	156
M1-7, M9 Motor Driver (Stepper Board)	157

M8 Motor Driver (Stepper Board)	158
Solenoids	159
Diverter (SOL1 and SOL8)	160
Entrance Idler (SOL2 and SOL3)	161
Anti-Static Brush	162
Cutter Module	163
Motor	163
Belt	163
Clutch	164
Blade	166
Cutter Shaft Ball Bearing	169
Cutter Encoder	170
Trim Tray	172
Trim Tray Home Switch	172
Trim Level Emitter	173
Trim Level Receiver	173
Steering Module	174
Alignment Module	174
Laminator Alignment Stepper Motor, Pulley and Bracket ...	176
Alignment Carriage Sub-Assy	177
Steering Stepper Motor	180
Steering Motor Belt (65 Groove)	182
Steering Drive Roller Shaft	183
Steering Idler Panel Weldment	184
Steering Idler Roller Assembly	185
Steering Idler Roller Bearing	187
Steering Drive Panel Weldment	188
Laminator Module	189
M8 Motor Driver	189

Cartridge Rail Plate	192
Rollers	193
Lower	193
Pressure.....	194
Locking Mechanism	195
Handle.....	196
Clamps.....	197
Alignment Sensor Bracket	199
Electronics & Controls Repair Procedures	201
24V Power Supply	201
AC Filter	202
Main Control Board	203
Communication Board	204
Chip Reader	204
Bracket.....	205
Breakout Board.....	205

Precautions



WARNING: Do not perform any repair with the power on or electrical power supplied to the machine.



DANGER: HIGH VOLTAGE

Before starting repair, please note the following precautions:

- Read all instructions carefully before operating the machine and prior to performing any procedure.
- Do not place anything on top of the unit.
- Keep the top clear of obstructions.
- Do not block the slots and opening on the unit, which are provided for ventilation.
- Do not place anything on the power cord.
- This equipment is not intended for use by children.

Tools Needed

- Needle nose pliers
- Torx Screwdrivers: T6, 10, 20
- Phillips Screwdriver
- Flathead Screwdriver
- 7mm Nut Driver
- 5.5mm Nut Driver
- 7mm Open End Wrench
- 5.5mm Open End Wrench
- Needle Nose Pliers
- Phillips Screwdriver
- Flathead Screwdriver
- Wire Cutters
- Metric Allen Key Set (1.5mm, 2mm, 2.5mm, 3mm, 4mm, 5mm)

Work Environment

Be sure to have a stable, clean working environment. Dust and dirt can get into the system components and cause a malfunction. Adequate lighting and proper tools can prevent accidentally damaging the internal components.

Pre-Requisites

In many cases it will be necessary to remove other parts to get to the area for repair.

Rear Cover

Remove

1. Disconnect the communication cable from the rear side of the machine and remove the MK 737 boxes.
2. Hold the rear cover in place while removing the (6) M4 X 8 screws from the rear cover.
3. Grasp the handle and remove the rear cover.



Install

1. Place the rear cover in position and tighten the (6) screws.
2. Install the MK 737 boxes.
3. Connect the communication cables.
4. Connect the power cord.

Undock the Laminator

This procedure moves the laminator to the service position.

1. Unplug the communications cable on the rear of the machine.

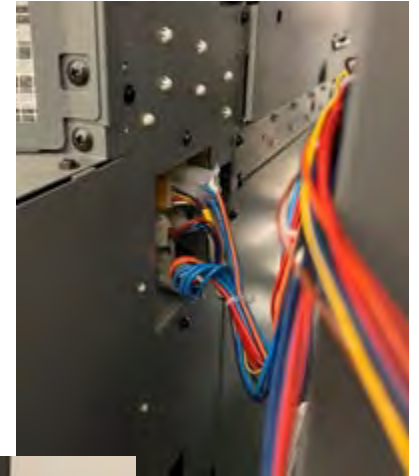
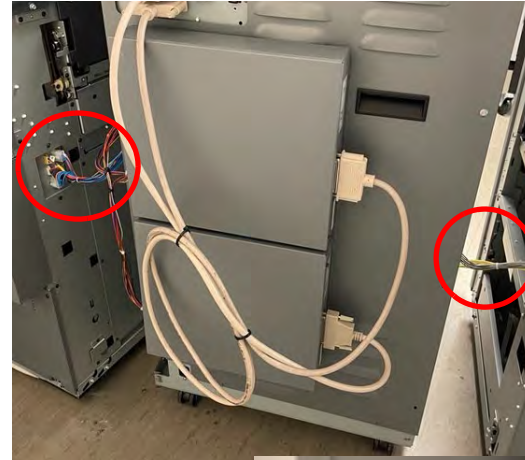

2. Remove the screw on the docking bracket.



3. Follow the manufacturer's instructions for undocking the downstream device.

Dock the Laminator

This procedure moves the laminator to the operating position.

1. Slide the laminator to the operating position, ensuring that the positioning stud in the upstream device slides into the positioning plate.



2. Slide in the upstream and downstream docking mechanisms and install the locking screws.
3. Connect the Communications cable.
4. Connect the power cord.
5. Run a small test job in both Laminator and Bypass mode to ensure the machine is working properly.

Cabinet

Top Cover

Remove

1. Open the Front Door.
2. Remove the [Rear Cover on page 110](#).
3. Remove the (4) Phillips screws from the top cover tabs (2 screws on front side and 2 screws from rear side).

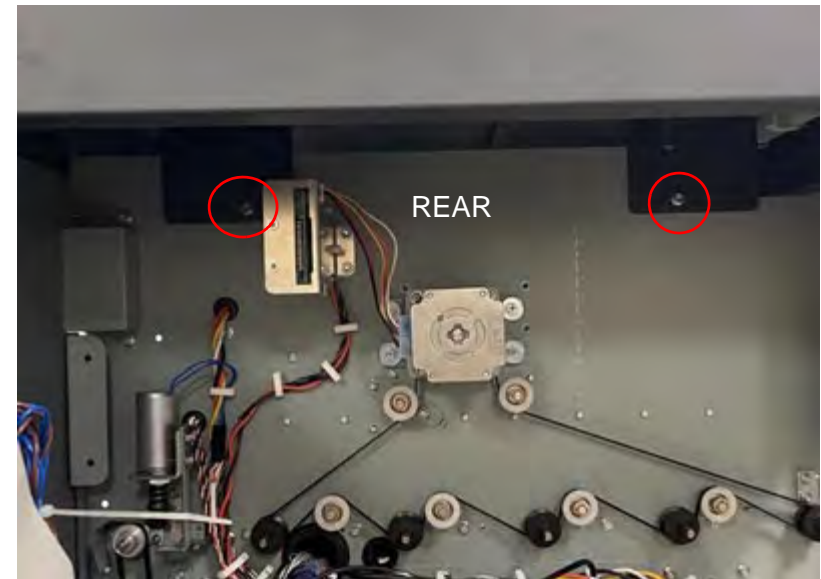
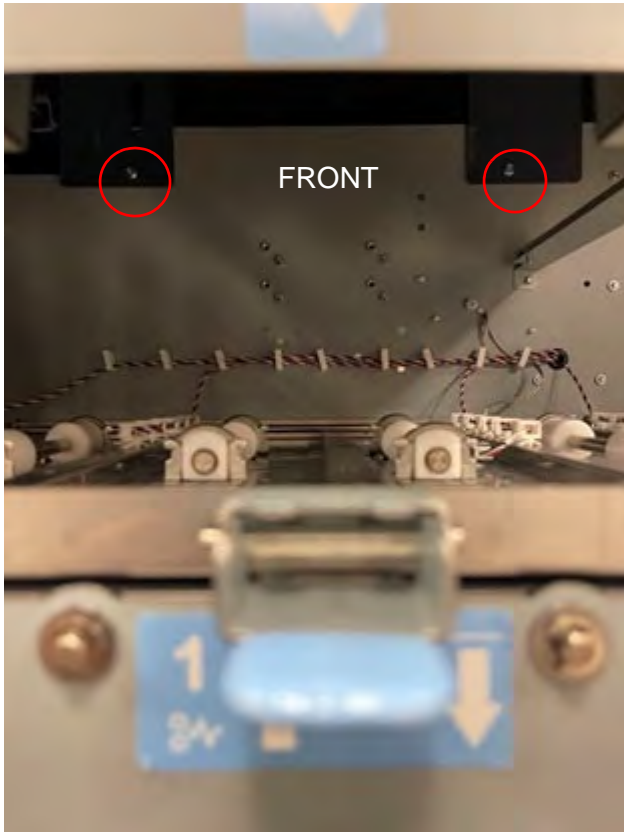

4. Disconnect the LCD panel connector and release the LCD cable from wire saddles.
5. Remove the top cover.

Install

1. Place the top cover in position so the tabs overlap the front and rear frame.
2. Install and tighten the (4) Phillips screws through the tabs.
3. Connect the LCD panel connector and place the LCD cable in the wire saddles
4. Close the Front Door.
5. Install the [Rear Cover on page 110](#).
6. Connect the Power Cord.

Front Door

1. Open the front door.
2. Support the door while removing the (2) screws from the bottom hinge bracket on the front door.



3. Lower the door down off the pin on the top hinge bracket.
4. Remove the front door.
5. Remove the [Interlock Switch on page 116](#) from the old door and install it on the new one.
6. Remove the magnet strike plate from the old door and install it on the new one.



Install

1. Insert the upper part of the door on to the pin.
2. Align the holes on the bottom hinge to the bracket and screw into place.
3. Close the door.
4. Run the [Door Latch on page 209](#) adjustment procedure.
5. Connect the power cord.

Bottom Hinge Bracket

1. Remove the [Front Door on page 113](#).
2. Remove the (2) screws from the bottom hinge bracket on the frame.



3. Install the new bracket on the door.
4. Align the holes on the bottom hinge to the frame and screw into place.
5. Close the door.
6. Run the [Door Latch on page 209](#) adjustment procedure.

Panel Open Magnet

1. Open the front door.
2. Remove the (2) screws holding the magnet.

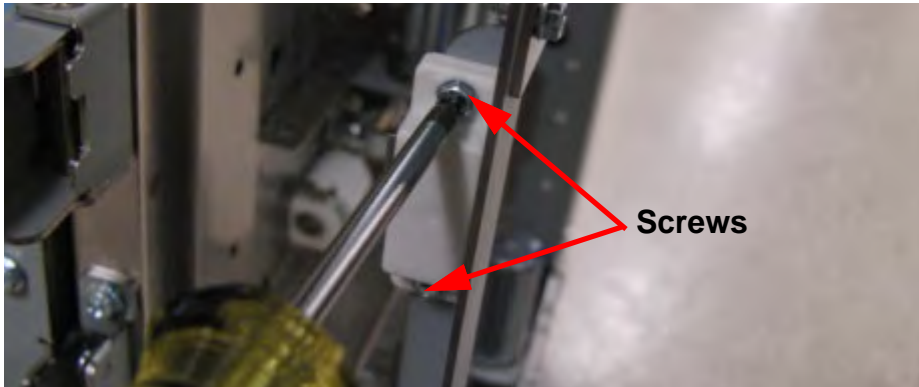

3. Install the new magnet and tighten the (2) screws.
4. Close the door.
5. Connect the power cord.

Door Latch

The door latch holds the door closed and the activating bracket tab depresses the door switch. The tab should press the switch button just so that it is close to bottoming out.

1. Open the front door and remove the (2) screws holding the latch.



2. Remove (1) screw from the top of the interlock box.

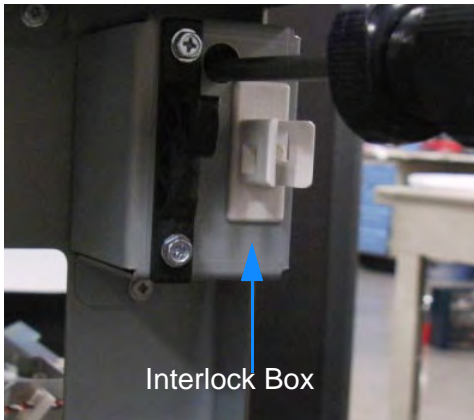

3. Place the new latch in position.
4. Replace the (2) screws on the interlock box.
5. Replace the (2) screws on the door latch.
6. Run the adjustment for the [Door Latch on page 209](#).
7. Close the front door.
8. Connect the power cord.
9. Test the door latch operation.

Interlock Switch

1. Open the front door.
2. Remove the (1) screw above the interlock box.



3. Press in the (2) tabs on the sides of the switch and remove the interlock switch from the bracket.
4. Note the location of the (4) wires, then disconnect them from the interlock switch.

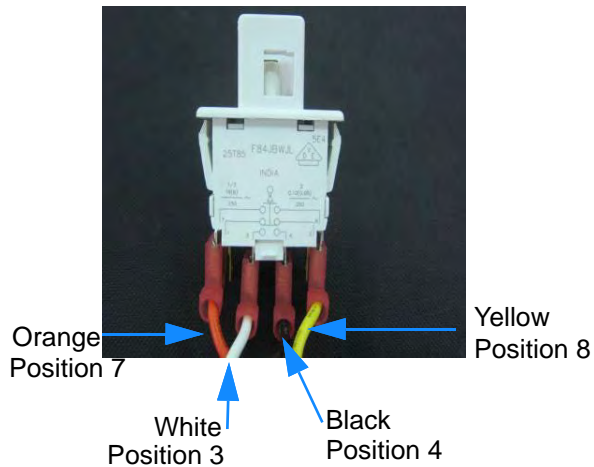
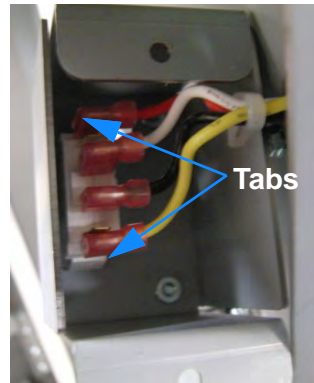

5. Place the new interlock switch into the bracket and press down until the tabs lock in place.
6. Connect the (4) wires to the new switch.
7. Place the bracket in place and tighten down the (2) screws.
8. Close the front door.
9. Connect the power cord.

Upstream Rear Side Cover

Remove

1. [Undock the Laminator on page 110](#) from the upstream and downstream equipment.
2. Remove the [Rear Cover on page 110](#).
3. Remove the (5) screws securing the upstream rear side cover.
4. Remove the cover.

Install

1. Place the cover in position, insert and tighten the (5) screws.
2. Install the [Rear Cover on page 110](#).
3. [Dock the Laminator on page 111](#).

Left Side Cover

Remove

1. [Undock the Laminator on page 110](#) from the upstream and downstream equipment.
2. Remove the (5) M4 screws on the cover.
3. Remove the cover.

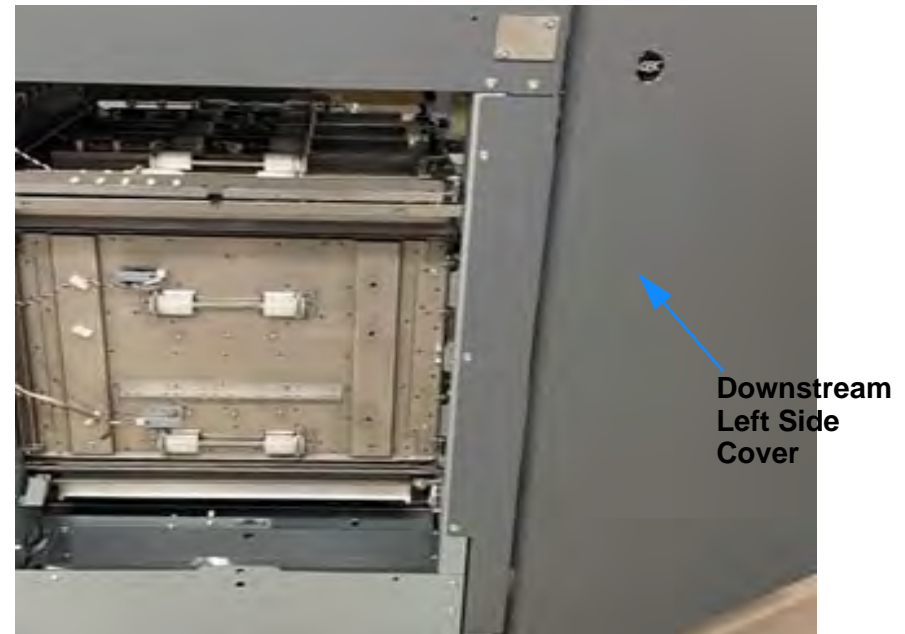

Install

1. Place the cover in position, insert and tighten the (6) screws.
2. [Dock the Laminator on page 111](#).

Downstream Rear Side Cover

Remove

1. [Undock the Laminator on page 110.](#)
2. Remove the [Rear Cover on page 110.](#)
3. Remove the (8) screws on the cover.
4. Remove the cover.

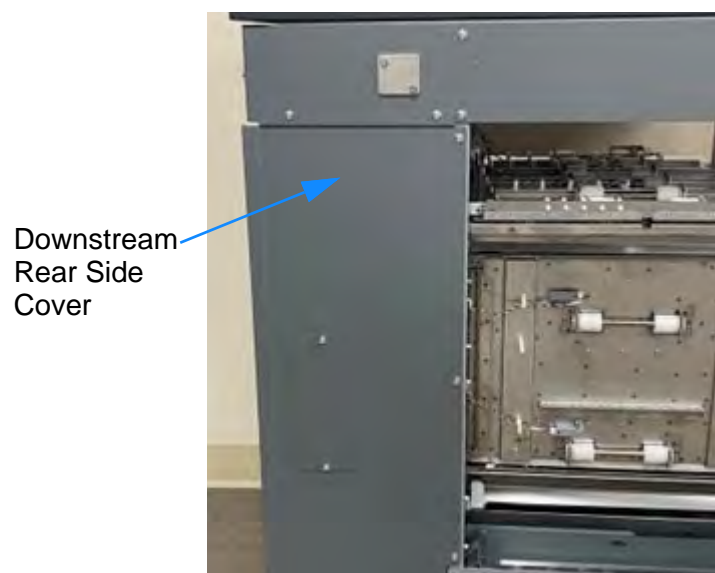

Install

1. Place the cover in position, insert and tighten the (7) screws.
2. Install the [Rear Cover on page 110.](#)
3. [Dock the Laminator on page 111.](#)

LCD Display

The display can be removed without removing the top cover, but removing the top cover may make it easier to access the components.

Remove

1. (optional) Remove the [Top Cover on page 112](#).
2. Open the front door.
3. Locate the LCD display under the top cover and disconnect the large ribbon cable from the LCD adapter board.



4. Disconnect the small ribbon cable from the LCD by gently pulling horizontally on the tabs of the cable connector to release it.



5. From underneath the top cover, remove the (4) screws holding the LCD display to the cover and remove the display.

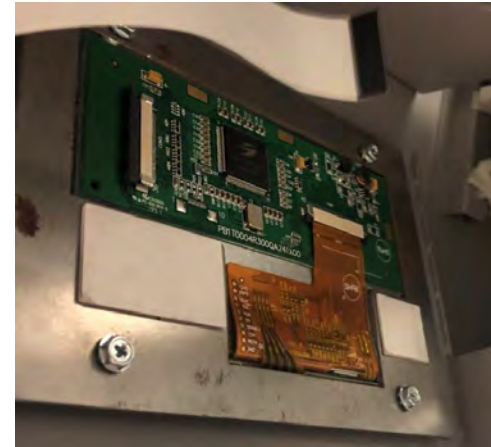

Install

1. Place the new LCD display in position on the underside of the top cover and tighten the (4) screws.
2. Connect the small ribbon cable to the LCD screen by placing the cable flat and pressing in on the plastic tabs of the cable connector to secure.
3. Connect the large ribbon cable to the adapter board.
4. Close the front door.
5. Connect the power cord.

Casters

1. Carefully lift the corner of the machine by the caster.
2. Loosen the jam nut.

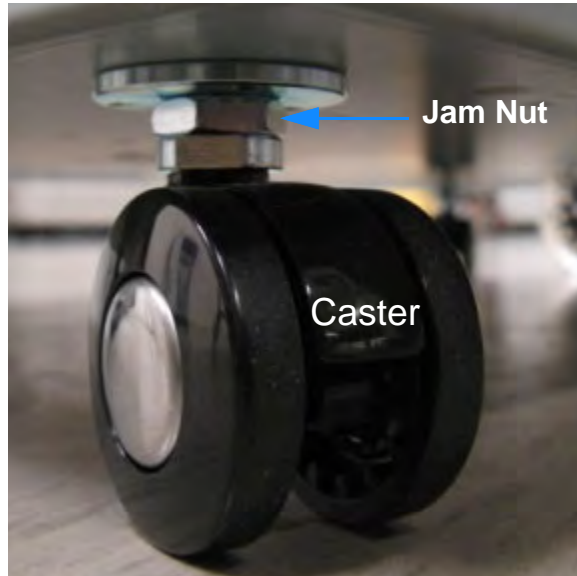

3. Unscrew the caster to remove it.
4. Place the new caster in position and screw it in.
5. Tighten the jam nut.
6. Lower the machine.
7. Connect the power cord.

Docking Brackets

Remove

1. Disconnect the communication cable.
2. [Undock the Laminator on page 110](#) to separate the laminator from the upstream and downstream devices.
3. Remove (8) M4 screws that hold the (4) docking brackets, then remove the brackets.

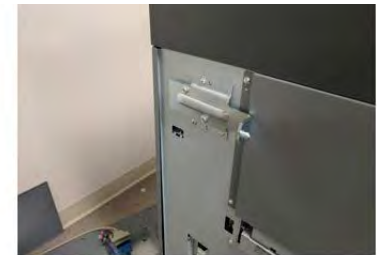

Install

1. Place the docking brackets in position on the upstream devices and tighten the screws.
2. [Dock the Laminator on page 111](#).
3. Connect the communication cable.
4. Connect the power cord.

Exhaust Fan

Remove

1. Remove the [Rear Cover on page 110](#).
2. Remove the screw on the right hand side of the exhaust fan bracket.

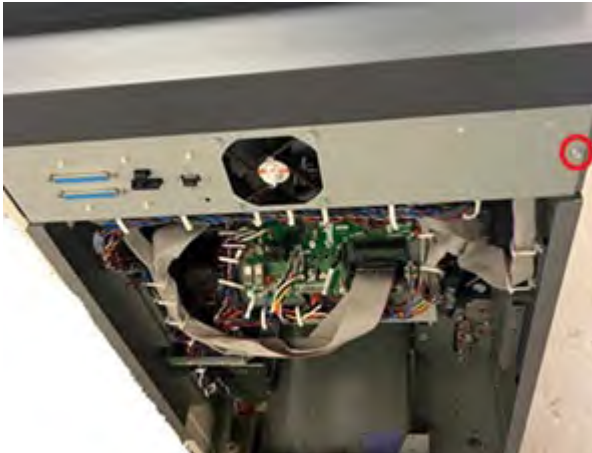

3. Tilt the exhaust fan bracket open by pulling from the right side. The left side has a hinge that will allow the bracket to open outwards.
4. To remove the exhaust fan from the bracket, disconnect cable (7715267) at connector J20 on the control board ([Wiring on page 263](#)).
5. Open the (3) wire saddles towards the bottom of the bracket.

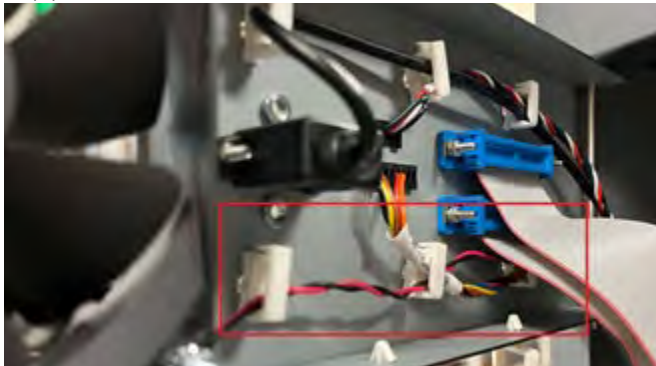

6. Remove the (4) screws from the front and the (4) nuts from the rear of the bracket.

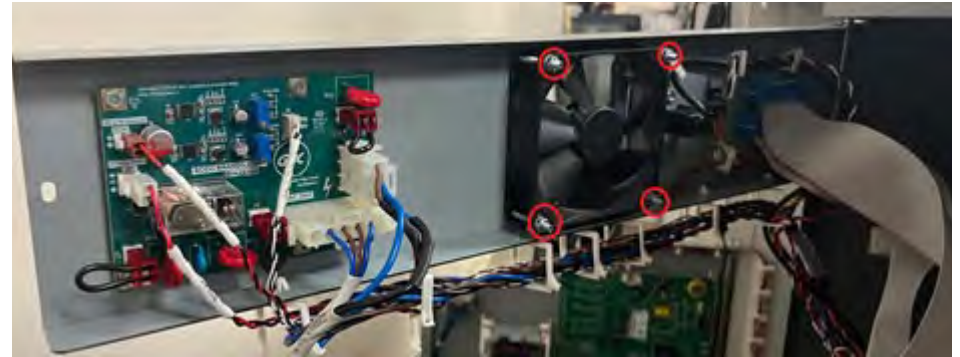

7. Open the wire saddles along the side of the frame that leads to the control board. Any saddle you can see the black/red fan wiring routed through needs to be opened in this step. Note the wire path boxed in red in the image below.



8. Remove the fan.

Install

1. Place the new fan in position on the bracket.

IMPORTANT: The fan should be installed such that air flows out of the machine. An arrow mark in the exhaust fan indicates the direction of air flow.

2. Install the (4) screws into the front and tighten the (4) nuts on the rear of the bracket.
3. Place cable (7715267) into the wire saddles.
4. Place the exhaust fan bracket assembly in position and tighten the screw.
5. Connect cable (7715267) to connector J20 on the control board ([Wiring on page 263](#)).
6. Install the [Rear Cover on page 110](#).
7. Connect the power cord.

Paper Path

Lower Entrance Panel

Remove

1. Open the front door.
2. Remove the (1) screw holding the grounding strap.



3. Remove the (1) E-clip from the front of the shaft.



4. Slide the shaft backwards until you can angle it downward.
5. Pull the panel out of the machine, sliding it down the shaft.

Install

1. Slide the panel up the shaft.
2. Reseat the shaft in the front frame.
3. Install the E-clip at the front end of the shaft.
4. Install the grounding strap.

Lower Exit Panel

1. Open the front door.
2. Remove the (1) screw holding the grounding strap.

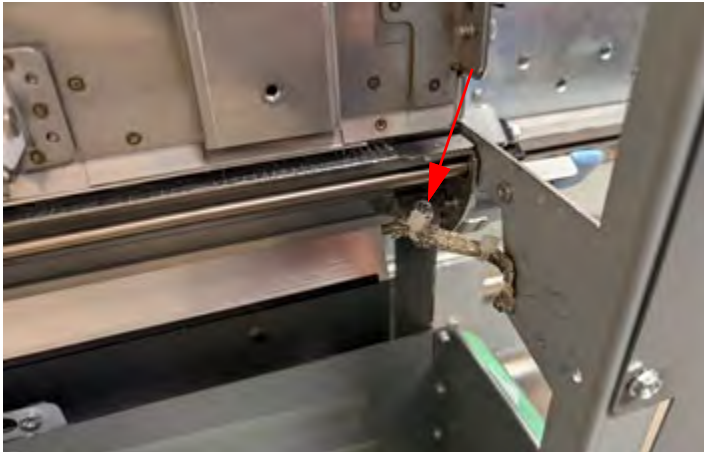

3. Remove the (1) E-clip from the front of the shaft.



4. Slide the shaft backwards until you can angle it downward.
5. Pull the panel out of the machine, sliding it down the shaft.

Install

1. Slide the panel up the shaft.
2. Reseat the shaft in the front frame.
3. Install the E-clip at the front end of the shaft.
4. Install the grounding strap.

Inner Entrance Panel

Remove

1. [Undock the Laminator on page 110.](#)
2. Remove the [Rear Cover on page 110.](#)
3. Remove the [Lower Entrance Panel on page 123.](#)
4. Remove the (2) screws from the front frame and the (2) screws from the rear frame that are used to mount the inner entrance panel.

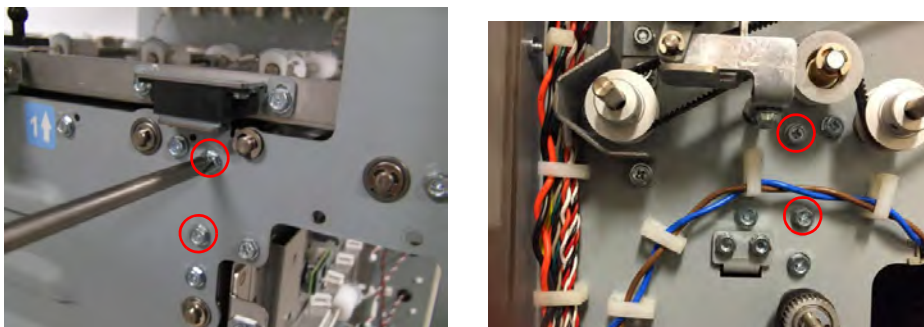

5. Remove the Inner Entrance Panel.



Install

1. Place the inner entrance panel in position and tighten the (2) screws in the front frame and the (2) screws in the rear frame that are used to mount panel.
2. Install the [Lower Entrance Panel on page 123.](#)
3. Install the [Rear Cover on page 110.](#)
4. [Dock the Laminator on page 111.](#)
5. Connect the power cord.

Entrance Idler Panel

Remove

1. Open the front door.
2. [Undock the Laminator on page 110.](#)
3. Open the cable clamps to release all the sensor cables.

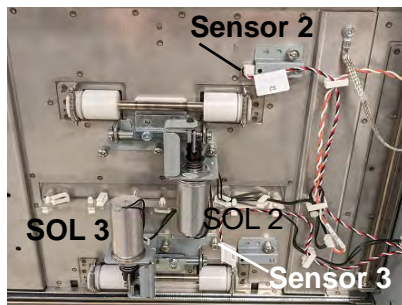

4. Disconnect the connectors for sensors S2 and S3.
5. Remove the screw for the ground strap.



6. Disconnect the connectors for solenoids SOL3 and SOL4 from the header.

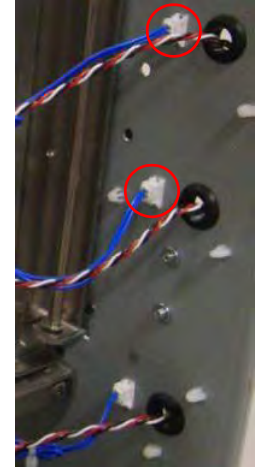

7. Remove the E-rings from the top and bottom of the idler panel shaft.

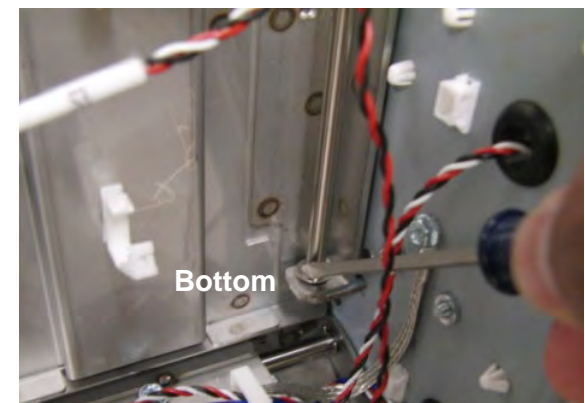
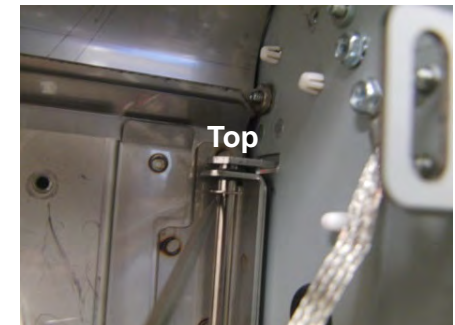

8. Open the entrance idler panel from the front side.



9. Carefully remove the shaft.



10. Grasp and remove the entrance idler panel.



11. Do the following to transfer the sensors, solenoid modules, idler rollers, springs, and panel magnets to the new weldment.

- [Idler Roller on page 138](#)
- [Sensors: S2, S3, S4, S5 on page 153](#) (Sensors 2 and 3 only)
- [Entrance Idler \(SOL2 and SOL3\) on page 161](#)

Install

1. Place the entrance idler panel in position.
2. Insert the shaft through the (2) holes at the left side of the entrance idler panel.
3. Install the (2) E-rings at the top and bottom of the shaft.
4. Connect the connectors for solenoids SOL3 and SOL4 to the header.
5. Connect the connectors for sensors S2, S3, and S4.
6. Place the sensor cables into the cable clamps, and close the clamps.
7. Install the screw for the ground strap.
8. Adjust the [Idler Panel Magnetic Latches on page 223](#).
9. [Dock the Laminator on page 111](#) to the upstream and downstream devices.
10. Close the front door.
11. Connect the power cord.

Entrance Drive Panel

Remove

1. Remove the [Rear Cover](#) on page 110.
2. Remove the [Cutter Module](#) on page 163.
3. [Undock the Laminator](#) on page 110.
4. Remove the [Entrance Idler Panel](#) on page 126.
5. Remove the [Stepper and Mount Assembly](#) on page 149.

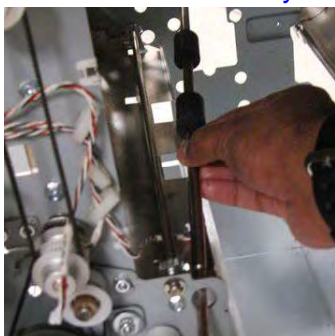

6. Remove the (5) screws that hold the entrance drive panel to the front frame.

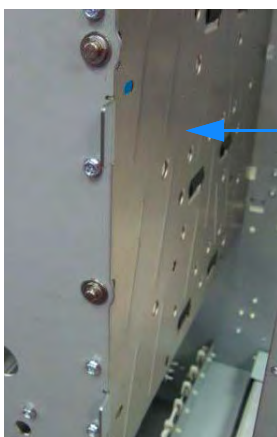

Entrance Drive Panel

7. Remove the (5) screws that hold the panel to the rear frame.



If you cannot remove the entrance drive panel, remove the [Idler Panel Mount Bracket](#) on page 139 from the lower position only.

8. Remove the Entrance Drive Panel.
9. Transfer the sensor boards and the clear cover sensor to the new panel weldment.

Install

1. Place the entrance drive panel in position.
2. Install the [Idler Panel Mount Bracket](#) on page 139 at the lower position.
3. Install the (5) screws (5) that hold the entrance drive panel to the rear frame and the (5) screws that hold it to the front frame.
4. Connect the (2) sensor board connectors.
5. Install the [Stepper and Mount Assembly](#) on page 149.
6. Install the [Entrance Idler Panel](#) on page 126.
7. Adjust the [Drive Panel](#) on page 224.
8. Install the [Rear Cover](#) on page 110.
9. Connect the power cord.

Exit Idler Panel

Remove

1. Open the front door.
2. [Undock the Laminator on page 110.](#)
3. Open the cable clamps and release sensor cables S4 and S5 at the sensor.

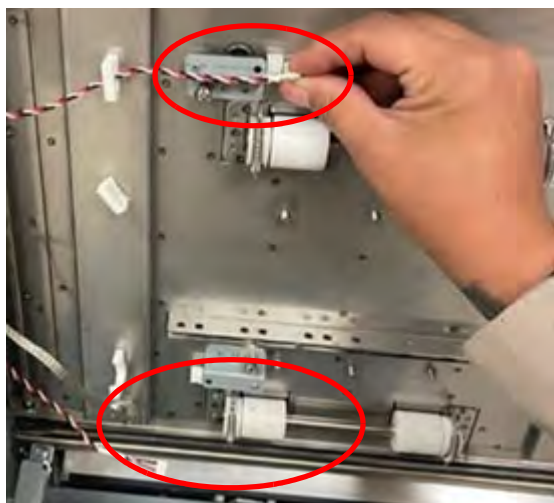

4. Remove the M4 screw for the ground strap.

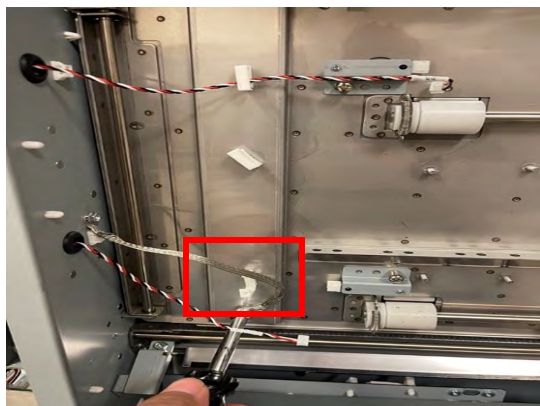

5. Remove the E-ring from the top and bottom of the idler panel shaft.



6. Open the entrance idler panel from the front side.



7. Carefully remove the shaft.



8. Grasp and remove the exit idler panel.



To replace the exit idler panel weldment, do the following procedures to remove and install these components.

- [Idler Roller on page 138](#)
- [Panel Close Magnet on page 137](#)

Install

1. Place the exit idler panel in position.
2. Insert the shaft through the holes at the left side of the Exit Idler Panel.
3. Install the E-Rings at the top and bottom of the shaft.
4. Place the sensor cables into the cable clamps and close.
5. Install the ground strap.
6. [Dock the Laminator on page 111](#) to the downstream devices.
7. Close the front door.
8. Connect the power cord.

Drive Exit Panel

Remove

1. [Undock the Laminator on page 110](#) from the upstream and downstream equipment.
2. Remove the [Lower Exit Panel on page 124](#).
3. Remove the [Exit Idler Panel on page 129](#).
4. Remove (5) screws from the front frame which mount the exit drive panel.

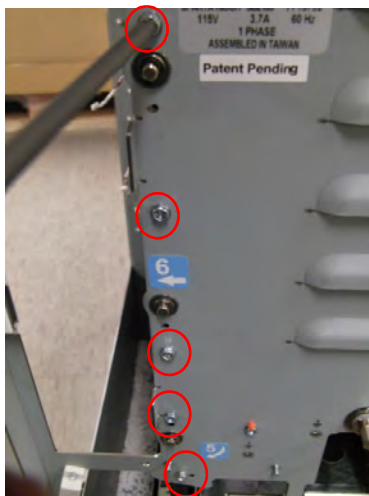

5. Remove (6) screws from the rear frame that mount the drive exit panel.



6. Remove the drive exit panel.

Install

1. Place the drive exit panel in position.
2. Install the (5) screws in the front frame and (5) screws in the rear frame.

3. Adjust the [Drive Panel on page 224](#).
4. Install the [Exit Idler Panel on page 129](#).
5. Adjust the [Idler Panel Magnetic Latches on page 223](#).
6. [Dock the Laminator on page 111](#) to the upstream and downstream equipment.
7. Connect the power cord.

Hinged Exit Panel

Remove

1. [Undock the Laminator on page 110.](#)
2. Remove the [Rear Cover on page 110.](#)
3. Remove the Drive roller cover removal to remove the downstream side roller cover.
4. Open the upper bypass panel.
5. Remove the (2) screws from the front frame and the (2) screws from the rear frame which mount the laminator lower exit panel.

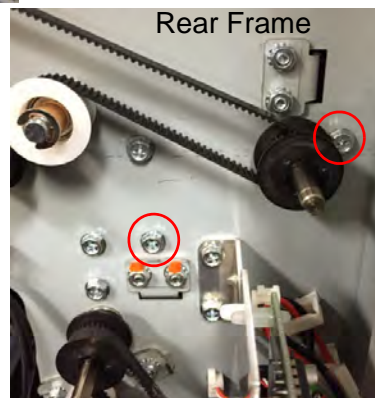
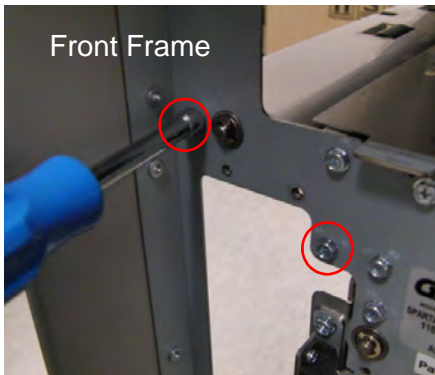

6. Remove the laminator lower exit panel.

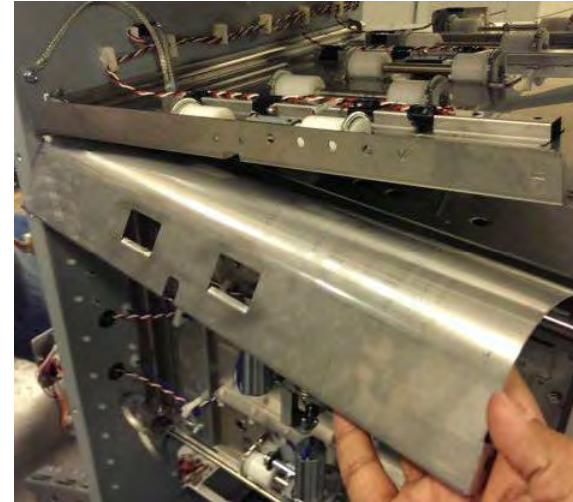

Install

1. Place the laminator lower exit panel in position.
2. Tighten the (4) screws used to mount the [Inner Entrance Panel on page 125.](#)
3. Install the [Rear Cover on page 110.](#)
4. Install Drive roller cover.
5. [Dock the Laminator on page 111](#) to the upstream and downstream equipment.
6. Connect the power cord.
7. Adjust the [Diverter Solenoid \(SOL1\) on page 210.](#)

Upper Bypass Panel

Remove

1. [Undock the Laminator on page 110.](#)
2. Remove the [Rear Cover on page 110.](#)
3. Unplug the sensors from the upper bypass panel and release the sensor cables from the cable clamps.

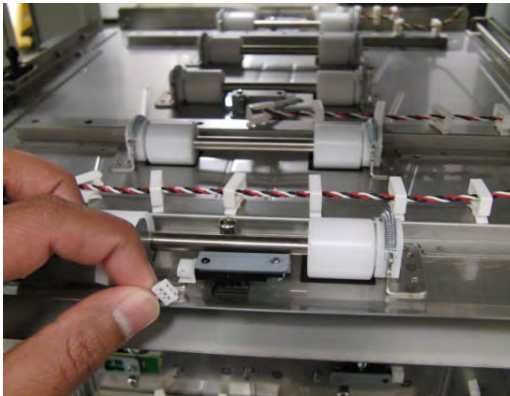

4. Remove the screw and nut for the ground strap.

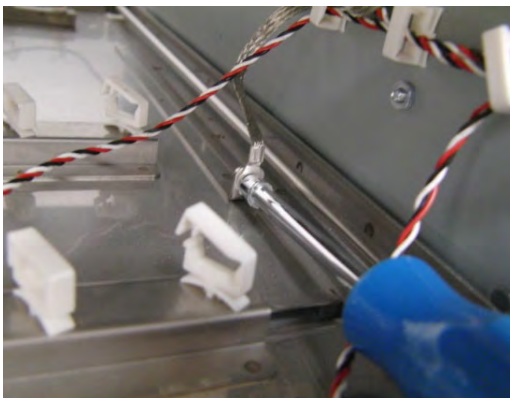

5. Remove (2) E-clips from the hinge shaft and remove the shaft.

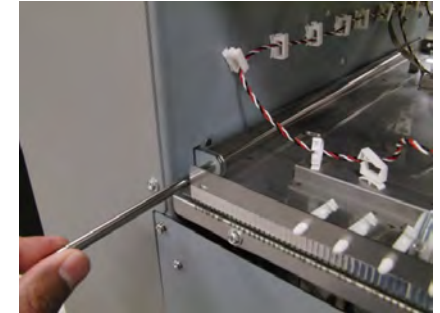

6. Remove (2) idler panel magnetic latches from the upper bypass assembly by unscrewing (4) screws.

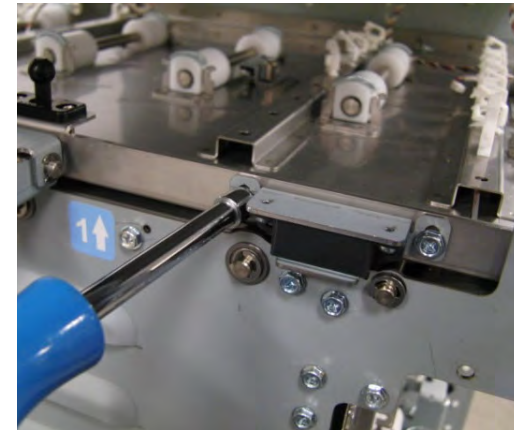

7. Remove the (2) screws from the handle assembly.

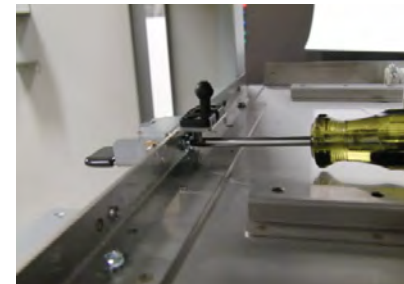

- Remove the [Idler Panel Mount Bracket on page 139](#) (singular) from the rear frame.



- Remove the upper bypass assembly.

Install

- Transfer the idler rollers, springs, sensors, bypass open sensor flag, and magnetic latches to the new part.
- Place the upper bypass assembly in position.
- Install the handle assembly.
- Install the (2) idler panel magnetic latches.
- Install the idler panel mount bracket on the rear frame.
- Place the shaft in position and install the (2) E-clips.
- Connect the sensors from the upper bypass panel and place the sensor cables in the cable clamps.
- Install the ground strap.
- Install the [Rear Cover on page 110](#).
- [Dock the Laminator on page 111](#) to the upstream and downstream equipment.
- Adjust the [Idler Panel Magnetic Latches on page 223](#).
- Connect the power cord.

Lower Bypass Panel

Remove

- Remove the [Upper Bypass Panel on page 134](#).
- Remove (4) M4 screws from the front frame.



- Remove (4) M4 screws from the rear frame.

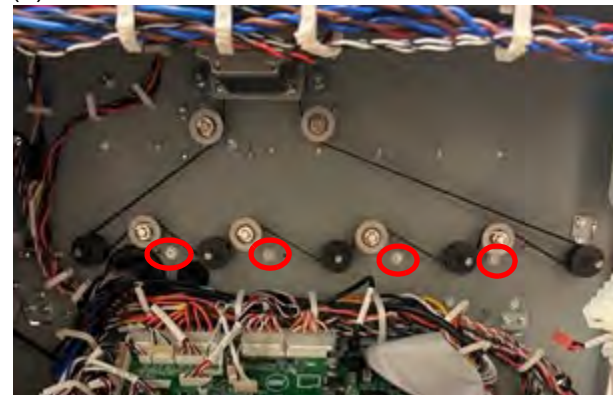

Install

Do the steps in reverse order.

Bypass Diverter

Remove

1. Remove the [Rear Cover on page 110](#).
2. Remove the E-clip from the diverter shaft on the front side.



3. Remove the M4 screws (2) from the diverter shaft on the rear side.

4. Remove the E-clip from the diverter shaft on the rear side.



5. Slide the diverter assembly to the back side and remove the part.



Install

1. Slide the diverter assembly into position through to the rear side.
2. Install the E-clip on the diverter shaft at the rear side.
3. Install the (2) M4 screws on the diverter shaft at the rear side.
4. Install the E-clip on the diverter shaft at the front side.
5. Install the [Rear Cover on page 110](#).
6. Connect the power cord.
7. Adjust the [Diverter Solenoid \(SOL1\) on page 210](#).

Panel Close Magnet

Use this procedure to replace the magnet and magnet bracket in these assemblies:

- [Entrance Idler Panel on page 126](#)
- [Exit Idler Panel on page 129](#)
- [Upper Bypass Panel on page 134](#)

1. Remove the (2) screws and (2) nuts.
2. Remove the magnet bracket.
3. Remove the old magnet.

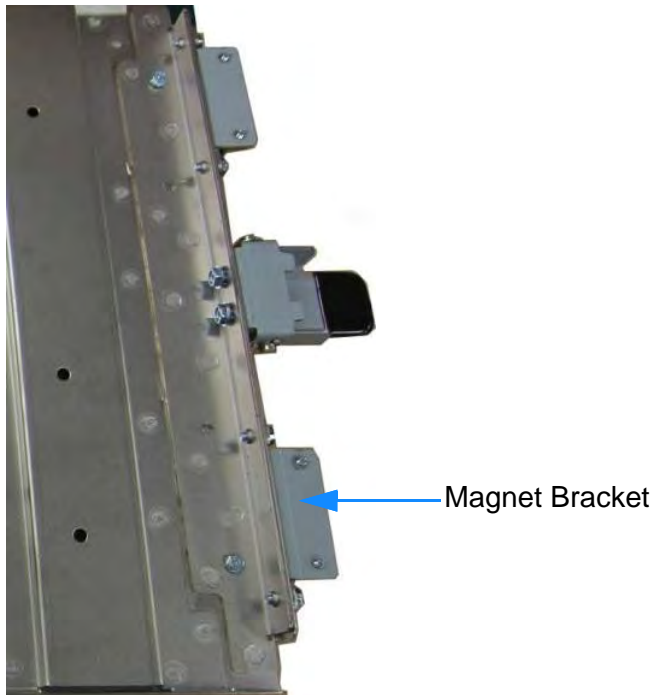

4. Place the magnet bracket in position and insert the screws and nuts.
5. Adjust the [Idler Panel Magnetic Latches on page 223](#).



6. Connect the power cord.

Idler Roller

Use this procedure for the idler rollers or the retaining springs in these assemblies:

- [Entrance Idler Panel on page 126](#)
- [Entrance Drive Panel on page 128](#)
- [Exit Idler Panel on page 129](#)
- [Upper Bypass Panel on page 134](#)

Remove

1. For the idler rollers in the entrance idler panel, acceleration roller panel, or exit idler panel, [Undock the Laminator on page 110](#).
2. For the idler rollers in the upper bypass panel, open the front door.
3. Lift the (2) extension springs up off of each of the (2) bearing housings at each end of the idler roller shaft.

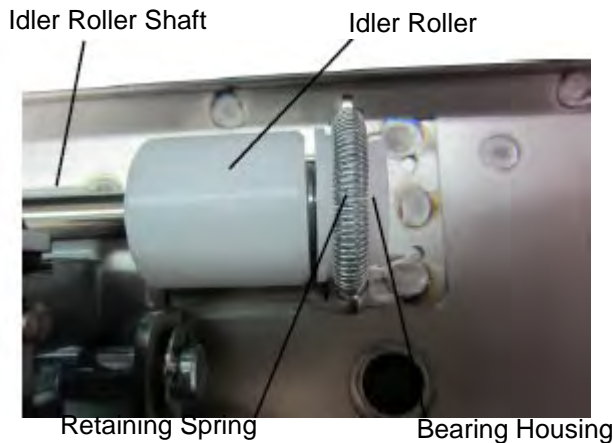

4. Remove the idler roller with the (2) bearing housings from the bushing forks.



5. Remove the (2) bearing housings at each end of the idler roller shaft.



Install

1. Place the (2) bearing housings on the ends of the idler roller shaft.
2. Place the new idler roller into the bushing forks making sure the flat surface of the bushing aligns in the fork.

Rollers are non-directional so it does not matter which end goes in each fork.



3. After the assembly is in place, gently pull the assembly outward and release to ensure it moves freely in the fork.
4. Place the (2) extension springs over the (2) bearing housings.
5. Place the hooks on the ends of the springs on the notches at the top of the bushing forks.
6. Connect the power cord.

Idler Panel Mount Bracket

Remove

1. Remove the [Rear Cover on page 110](#).
2. Locate the appropriate idler panel mount bracket.

There are (6) idler panel mount brackets in the machine.

NOTE: To remove the [Entrance Drive Panel on page 128](#), you need only remove the lower idler panel mount bracket.

3. Remove the (2) nuts on the bracket.

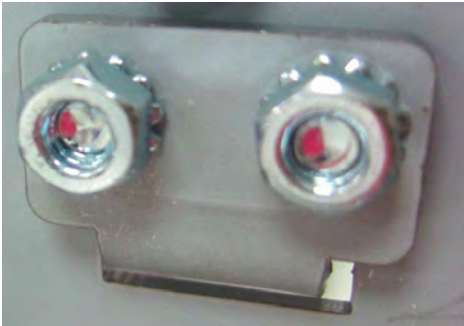

Install

1. Place the bracket in position and tighten the nuts.
2. Install the [Rear Cover on page 110](#).
3. Connect the power cord.

Flange Ball Bearing

1. Locate the flange ball bearing.

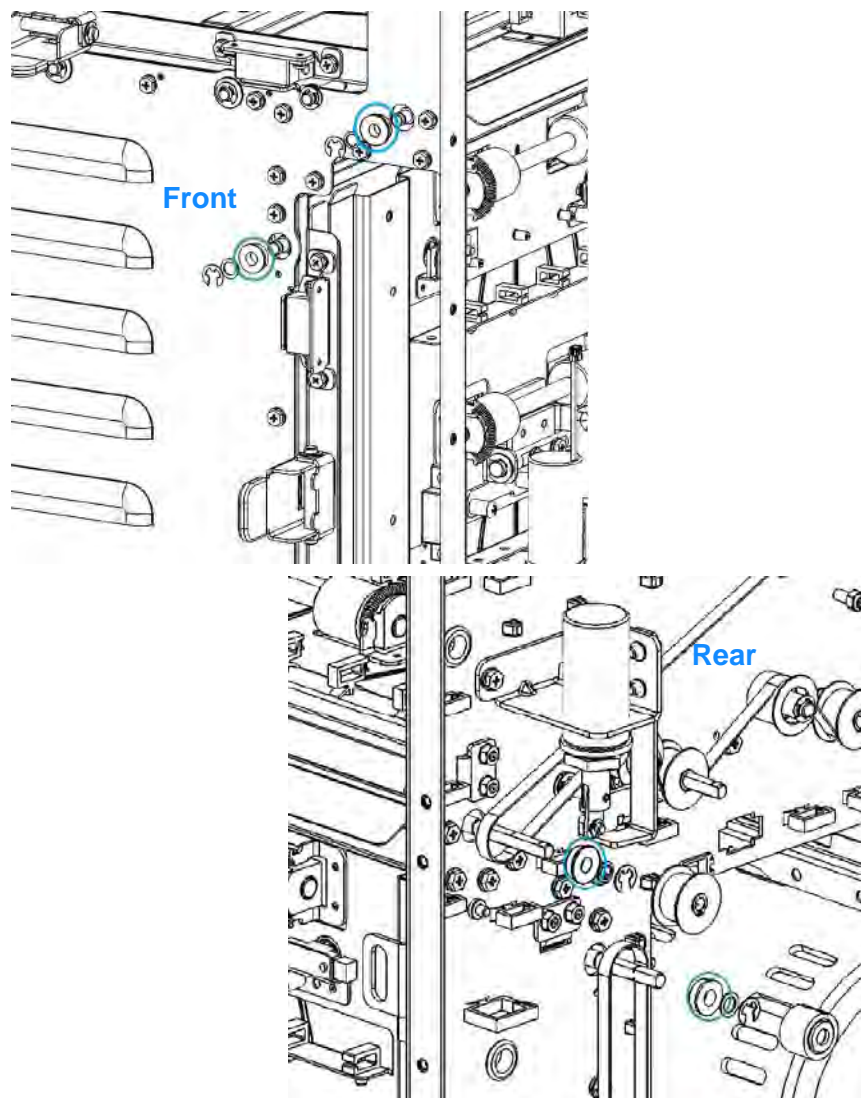

There are 22 flange ball bearings on the frame - shown in blue color.

There are 2 flange ball bearings on the frame - shown in green color.

2. Remove the E-ring.
3. Remove the flat washer.
4. Remove the flange ball bearing.

NOTE: To replace a bearing from the rear side, see [Timing Pulley on page 143](#) to remove the pulley.

5. Place the new flange ball bearing in position.
6. Install the flat washer.
7. Install the E-ring.
8. Connect the power cord.

Snap-in Bearing

Use this procedure for the snap-in bearings located in the following assemblies:

- [Entrance Idler Panel on page 126](#)
- [Entrance Drive Panel on page 128](#)
- [Upper Bypass Panel on page 134](#)
- [Exit Idler Panel on page 129](#)
- [Lower Exit Panel on page 124](#)

1. Click on the relevant panel link above to remove and access the snap-in bearing.

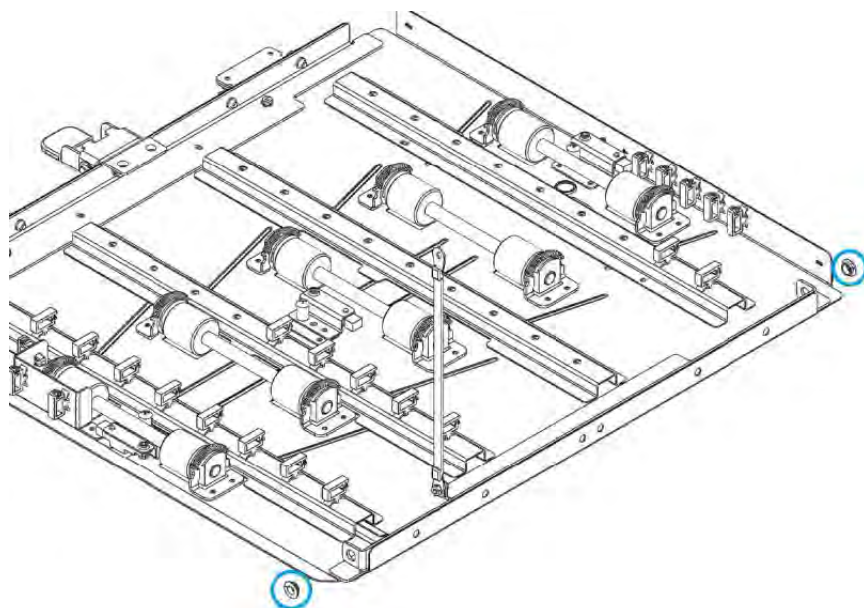

2. Remove the snap-in bearing.
3. Place the new bearing in position.

4. Install the panel:
 - [Entrance Idler Panel on page 126](#)
 - [Entrance Drive Panel on page 128](#)
 - [Upper Bypass Panel on page 134](#)
 - [Exit Idler Panel on page 129](#)
 - [Lower Exit Panel on page 124](#)
5. Connect the power cord.

Bearing Housing

Use this procedure to for the bearing housings on the idler rollers in these assemblies:

- Entrance Idler Panel on page 126
- Entrance Drive Panel on page 128
- Exit Idler Panel on page 129
- Upper Bypass Panel on page 134

1. Remove Idler Roller on page 138.

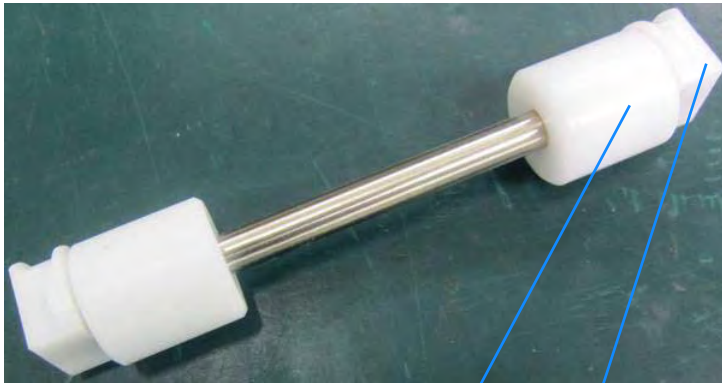

Idler Roller
Bearing Housing

2. Remove the (2) bearing housings from the end of the shaft.



3. Place the new bearing housings on the ends of the shaft with the flange of the bearing facing in toward the idler roller.

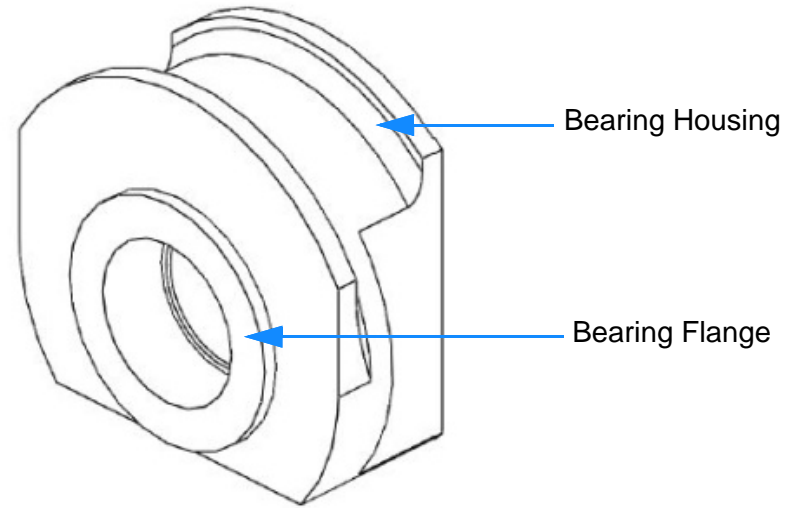

4. Install the Idler Roller on page 138.

Drive Idler Roller

1. Remove the [Drive Roller Assembly on page 147](#).
2. Remove the E-ring and the spacer.
3. Slide out the old idler roller from the stud.

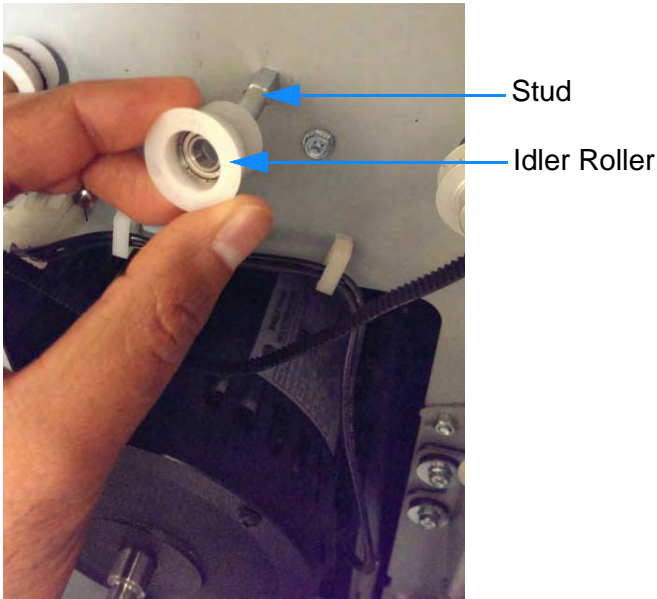

4. Place the new idler roller on the stud.
5. Install the spacer and E-ring.
6. Install the [Drive Roller Assembly on page 147](#).
7. Connect the power cord.

Timing Pulley

1. Remove the [Rear Cover on page 110](#).
2. Replace the appropriate [Timing Belts on page 144](#).
3. Remove the retaining ring from the roller shaft.
4. Slide out the timing pulley.



5. Slide the new timing pulley in position on the shaft and install the retaining ring.
6. Install the appropriate timing belt.
7. Adjust the relevant timing belt (see [Adjustments on page 207](#)).
8. Install the [Rear Cover on page 110](#).
9. Connect the power cord.

Timing Belts

Single Sided Belts

Belt Type	Qty	Motor	Replacement
539T, 2mm 2GT	1	M6	Drive Roller Assembly on page 147
132T, 2mm 2GT	1	M7	132T Timing Belt on page 144
166T, 2mm 2GT	1	M2	166T Timing Belt on page 145
197T, 3mm 3GT	1	M1	197T Timing Belt on page 146
162T, 3mm 3GT	1	M9	162T Timing Belt on page 146

132T Timing Belt

The 132T belt is on motor M7.

1. Remove the [Rear Cover on page 110](#).
2. Loosen the tensioner and remove the belt.



3. Place the new belt around the pulleys.
4. Adjust the belt tension, see [132T Timing Belt on page 220](#).
5. Install the [Rear Cover on page 110](#).
6. Connect the power cord.

166T Timing Belt

1. Remove the [Rear Cover on page 110](#).
2. Loosen the tensioner and remove the belt.

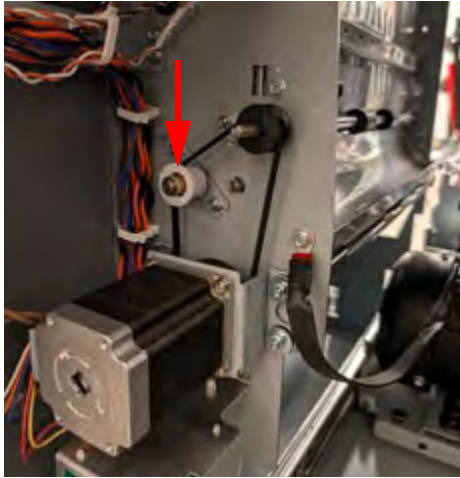

3. Place the new belt around the pulleys.
4. Adjust the belt tension per [166T Timing Belt on page 219](#).
5. Install the [Rear Cover on page 110](#).
6. Connect the power cord.

539T Timing Belt

The 539T is located on the M6 bypass motor.

1. Remove the [Rear Cover on page 110](#).
2. Loosen the tensioner and remove the belt.

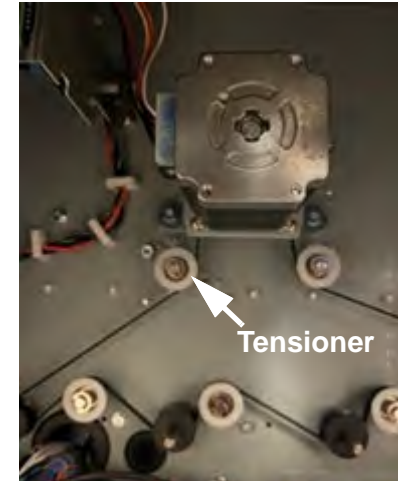

3. Place the new belt around the (11) pulleys.



4. Adjust the belt tension per [539T Timing Belt on page 218](#).
5. Install the [Rear Cover on page 110](#).
6. Connect the power cord.

197T Timing Belt

1. Remove the [Rear Cover on page 110](#).
2. Loosen the tensioner and remove the belt.



3. Place the new belt around the pulleys.
4. Adjust the belt tension per [197T Timing Belt on page 221](#).
5. Install the [Rear Cover on page 110](#).
6. Connect the power cord.

162T Timing Belt

The 162T Timing Belt is located on the M9 motor.

1. Remove the [Rear Cover on page 110](#).
2. Loosen the tensioner and remove the belt.

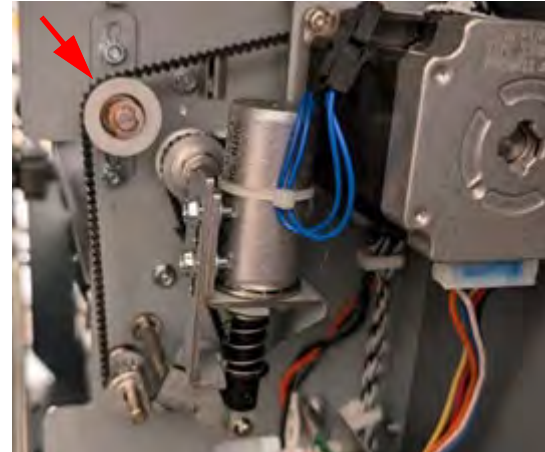

3. Place the new belt around the pulleys.
4. Adjust the belt tension per [162T Timing Belt on page 221](#).
5. Install the [Rear Cover on page 110](#).
6. Connect the power cord.

Drive Roller Assembly

Use this procedure to remove and install the drive roller assembly used in Nips N1 - N14 only.

For Nip N5, see [Stepper and Mount Assembly on page 149](#).

Remove

1. Remove the [Rear Cover on page 110](#).
2. Open the front door.
3. Locate the relevant driver roller.

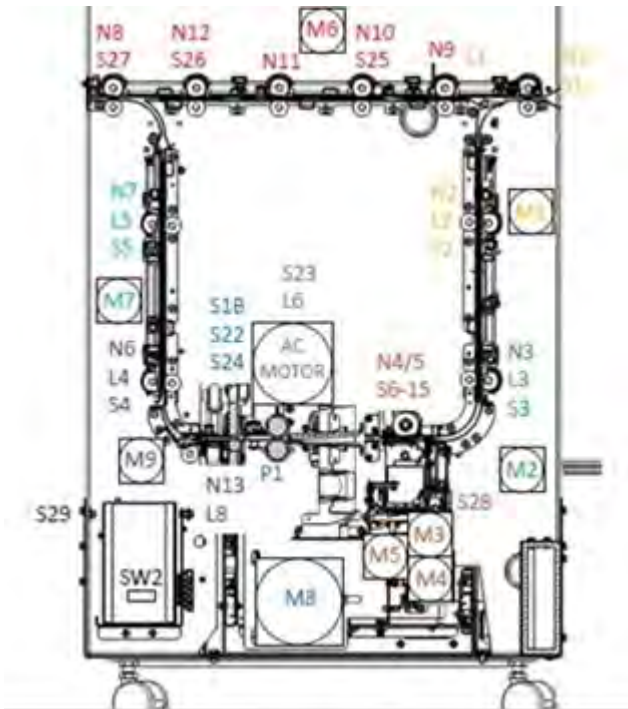

4. For all drive rollers except N1 and N11, remove the cutter module.

5. Remove the [Timing Belts on page 144](#) from the appropriate driver roller shaft.
6. Remove the [Timing Pulley on page 143](#) from the appropriate driver roller shaft.
7. Remove the E-ring and the washer from the end of the drive roller shaft at the **front** of the machine.

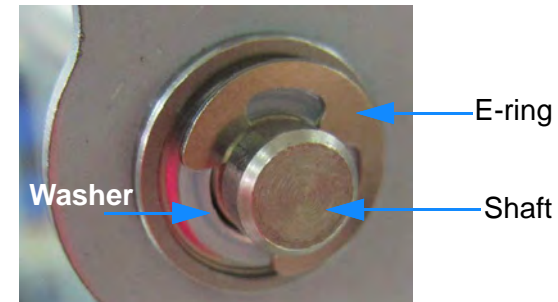

8. Remove the E-ring and the washer from the end of the drive roller shaft at the **rear** of the machine.

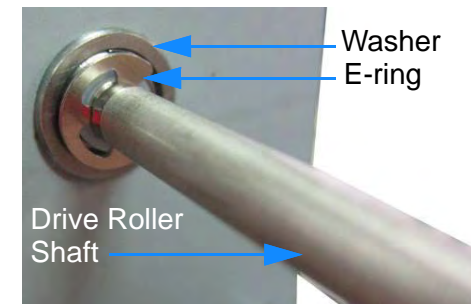

9. Remove the drive roller.

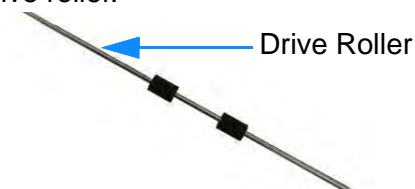

10. Remove the bearing from the **front** of the machine.
11. Remove the bearing from the **rear** of the machine.

Install

1. Place the drive roller in position
2. Place the bearing in position at the **front** of the machine.
3. Place the bearing in position at the **rear** of the machine.
4. Place the washer and the E-ring in position at the end of the drive roller shaft at the **front** of the machine and do the same for the **rear** of the machine.
5. Install the [Timing Pulley on page 143](#) on the appropriate drive roller.
6. Install the [Timing Belts on page 144](#) on the appropriate drive roller.
7. Install the [Rear Cover on page 110](#).
8. Close the front door.
9. Connect the power cord.

Stepper and Mount Assembly

Use this procedure for the Entrance Motor (M1), Accel Motor (M2), Exit Motor (M6), Decel Motor (M7), or Bypass Motor (M8).

Remove

1. Remove the [Rear Cover on page 110](#) and locate the affected motor.

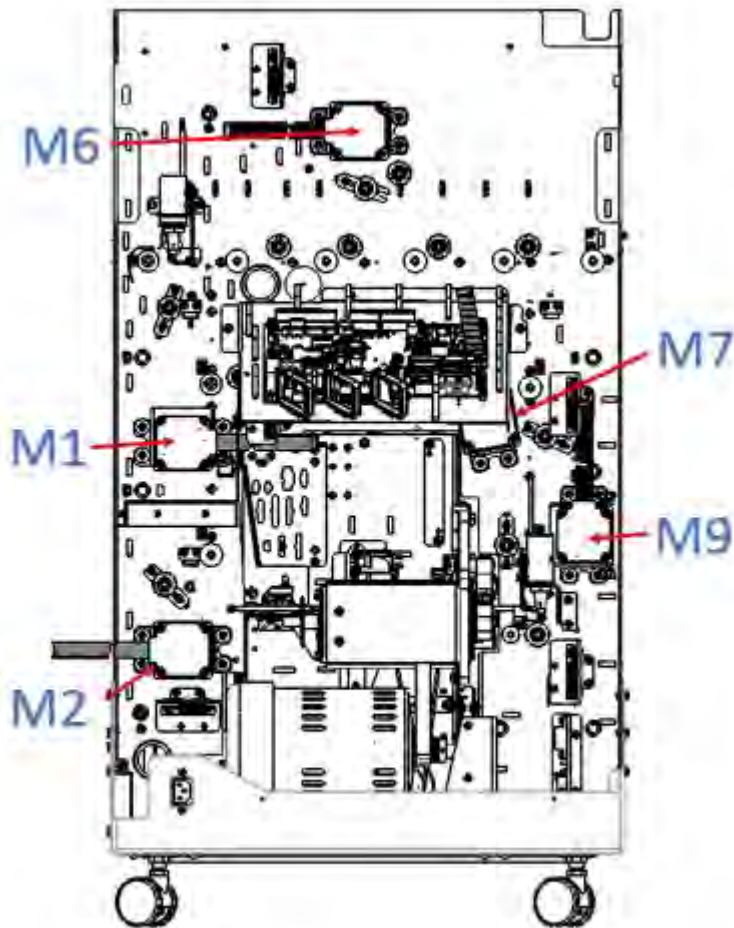

2. Disconnect the motor connector from the corresponding motor driver.
3. Loosen the corresponding timing belt tensioner by loosening the (2) M4 nuts.
4. Remove the (4) M4 screws or nuts and the flat washer and the stepper and mount assembly from the rear panel.

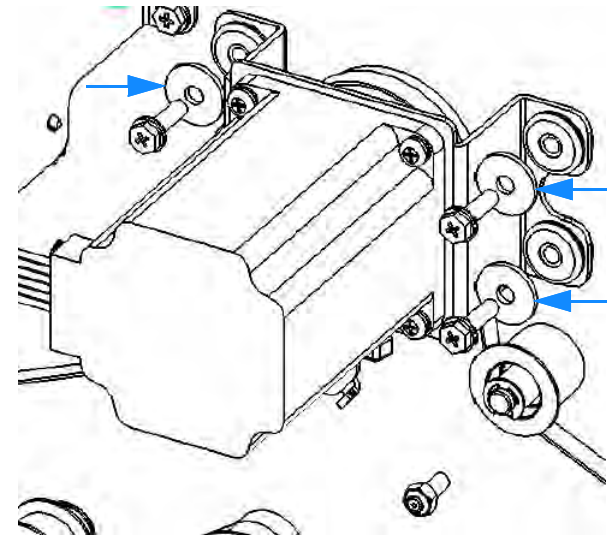

The 4th set is on the bottom left side of the motor, which is not shown.

Install

1. Place the stepper and mount assembly in place and tighten the (4) screws.
2. See [Timing Belts on page 144](#) and adjust the relevant belt's tension.
3. Connect the motor connector.
4. Install the [Rear Cover on page 110](#).
5. Connect the power cord.

Paper Path Sensors

[Parts List on page 240.](#)

Sensor #	Sensor Type	Sensor #	Sensor Type
1 on page 151	Entrance	22 on page 151	Post Cut
1b on page 151	Paper Trail Edge	24 on page 151	Film Present
2, 3, 4 & 5 on page 153	Paper Path Sensor	25 page 151	Bypass
9 on page 155	Skew Sensor Board	26 page 151	Bypass
10 on page 155	Skew Sensor Board	28 on page 154	Align Home
11 on page 156	Alignment	27 on page 151	Exit
12 on page 156	Alignment		
13 on page 156	Alignment		
14 on page 156	Alignment		
15 on page 156	Alignment		

Sensors: S1, S25, S26 and S27

1. Open the front door.

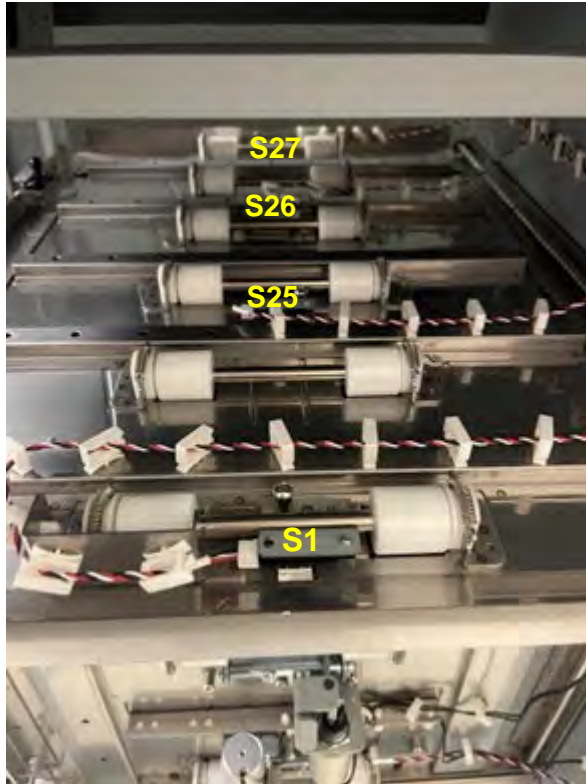

2. Disconnect the sensor connector at the sensor.
3. Remove the barrel screw that secures the sensor to the sheet metal part.
4. Remove the old sensor and place the new one in position and tighten the barrel screw.
5. Close the front door.
6. Connector the power cord.

Sensors: S1B, S22 and S24

S1B Receiver or S24 Sensor

1. Open the front door and pull out the lamination drawer.
2. Use a 5.5mm driver to remove the (2) nuts on the sensor assembly.

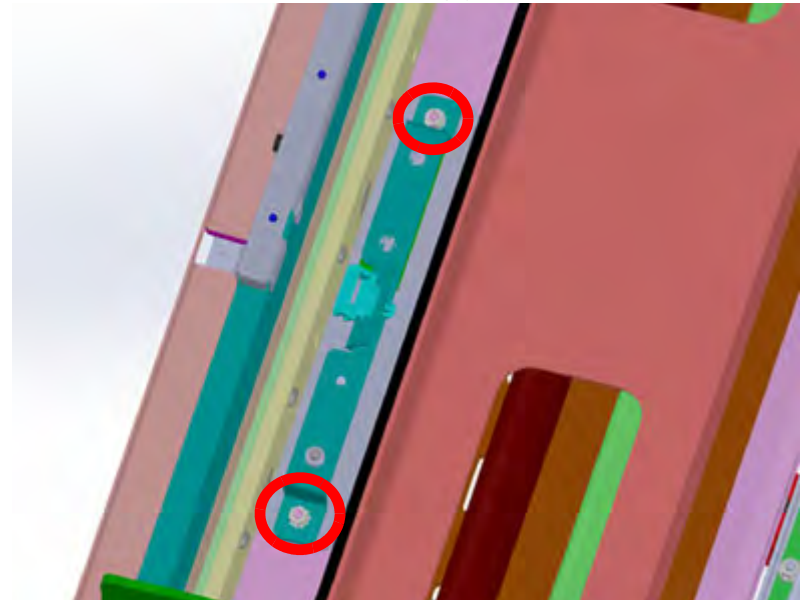

3. Lift the sensor assembly out of the machine and unplug **S1B Receiver or S24 sensor**.
 4. Remove the (2) nuts using a 7mm driver and replace the S1B receiver.
- OR**
5. Remove the screw using a 5.5mm driver and replace the **S24** sensor.
 6. Plug the sensor in and install the sensor assembly bracket.
 7. Push the lamination drawer in and close the front door.
 8. Connect the power cord.

S1B Emitter

1. Remove the [Locking Mechanism on page 195](#).
2. Remove the bottom [Pressure Roller on page 24](#).
3. Unplug the **S1B Emitter**.
4. Remove the (2) nuts using a 7mm driver and replace the S1B Emitter.

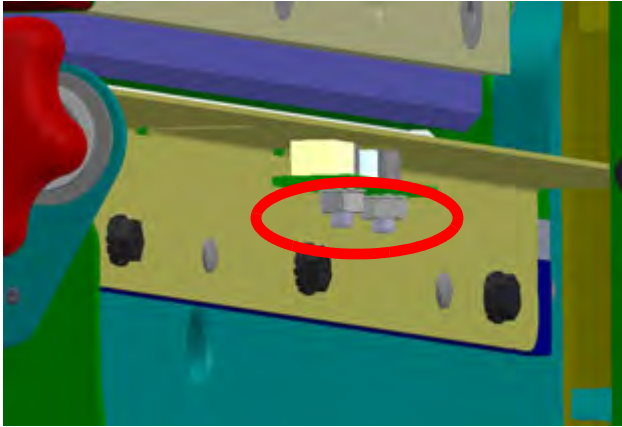

5. Install the pressure roller.
6. Install the locking mechanism.
7. Connect the power cord.

S22 Sensor

1. Open the front door and pull out the lamination drawer.
2. Use a Phillips screwdriver to remove the screw securing the sensor bracket by going through the hole in the bracket to access the screw.



3. Remove the bracket and unplug **S22 sensor**.
4. Remove the screw using a 5.5mm driver and replace the S22 sensor.
5. Plug in the sensor.
6. Install the bracket, properly aligning the dowel hole.

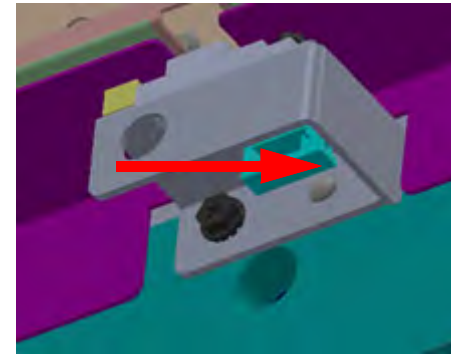

7. Push the lamination drawer in and close the front door.
8. Connect the power cord.

Sensors: S2, S3, S4, S5

1. [Undock the Laminator on page 110](#) from the upstream and downstream equipment.
2. Remove the docking bracket, as needed, to access the sensor.
3. Disconnect the sensor wire and the sensor.
4. Remove the barrel screw that secures the sensor to the sheet metal part.

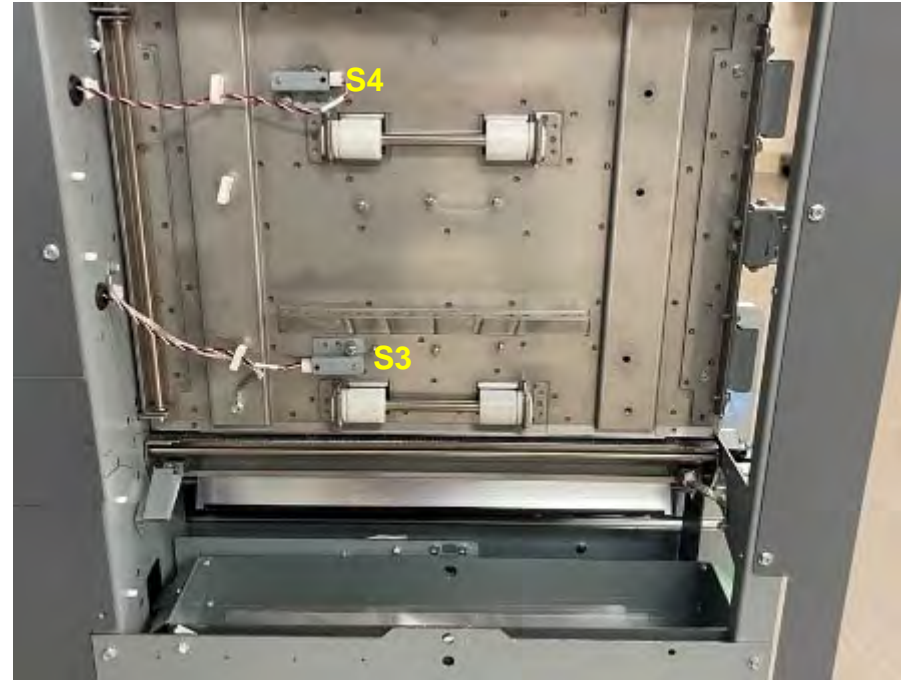
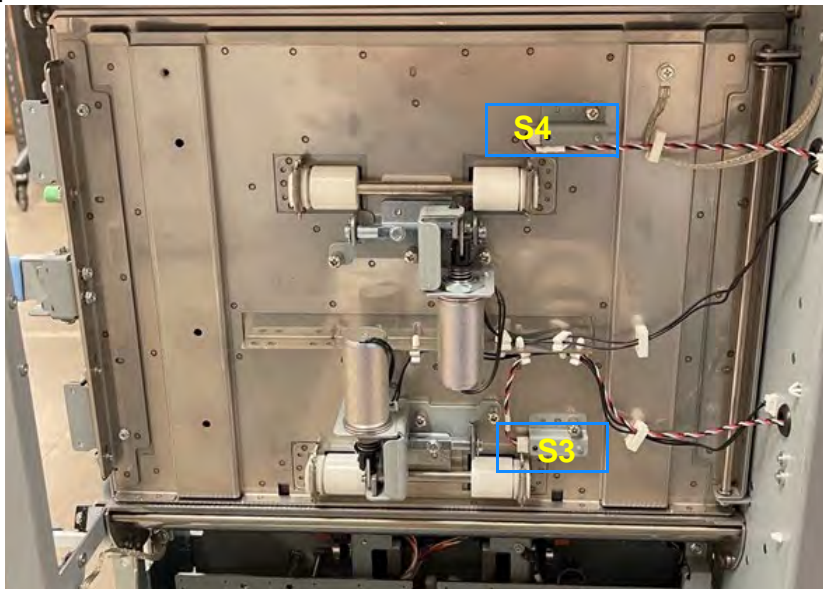

5. Remove the old sensor and place the new one in position and tighten the barrel screw.
6. Close the front door.
7. [Dock the Laminator on page 111](#) to the upstream and downstream equipment.
8. Connector the power cord.

Sensor S28

1. [Undock the Laminator on page 110](#) from the upstream and downstream equipment.
2. Disconnect the sensor connector at the sensor.

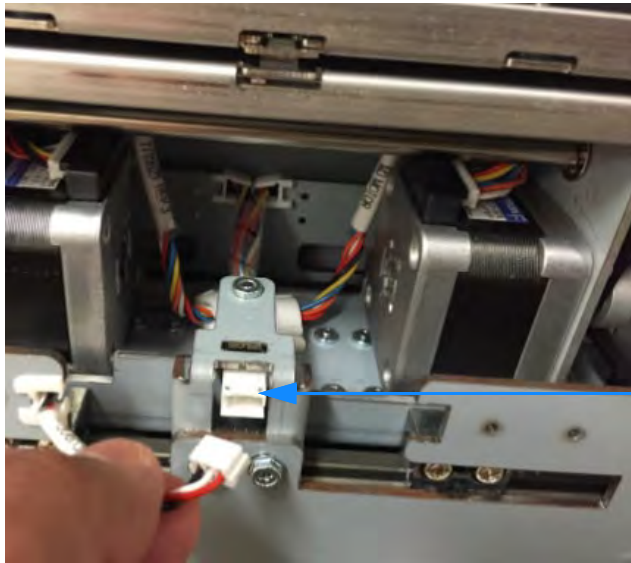

Connector

3. Remove the (2) M3 screws that secure the sensor to the bracket.

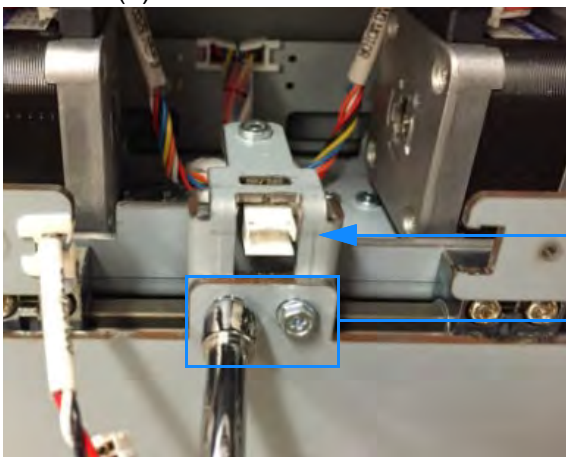

Bracket

Screws

4. Remove the sensor sub-assembly.



5. Place the new sensor in position and tighten the (2) M3 screws that secure the sensor to the bracket.
6. Connect the sensor connector to the sensor.
7. Close the front door.
8. [Dock the Laminator on page 111](#) to the upstream and downstream equipment.
9. Connector the power cord.

Sensors 6 through 10

1. Open the front door.
2. Pull out the laminator drawer.
3. Locate the skew board on the aligner module

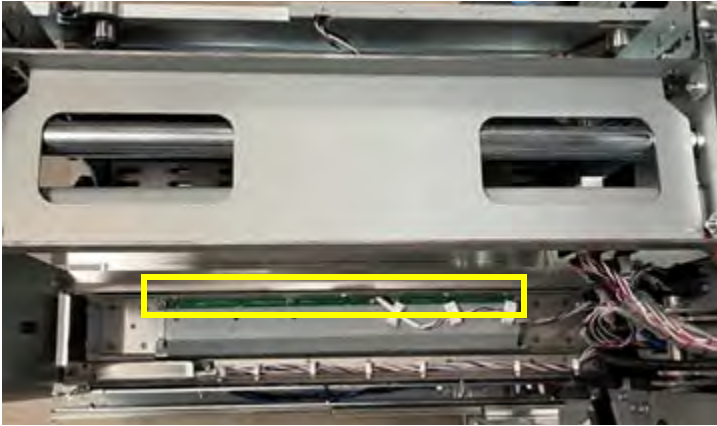

4. Remove the (4) M4 nuts and (4) washers located beneath the nuts.

IMPORTANT: Do NOT remove the washers beneath the board.

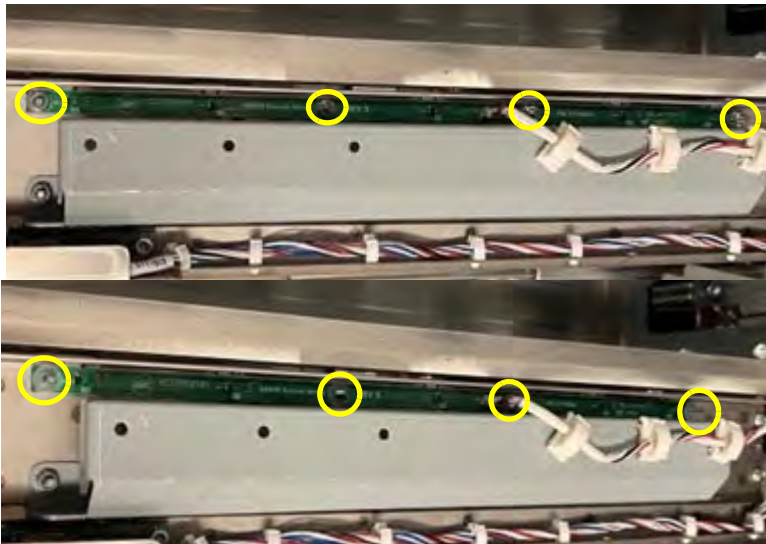

5. Disconnect the skew board connector and remove the skew board.
6. Install the new skew sensor board in position ensuring that S6 is oriented closest to the front of the door.
7. Install the (4) washers and tighten the (4) nuts.
8. Connect the skew sensor board connector.
9. Push in the laminator drawer.
10. Connector the power cord.
11. Run [Sensors on page 11](#) to confirm the skew board is fully functioning.
12. Resume normal operation.

Sensors 11 through 15

1. Open the front door.
2. Pull out the laminator drawer.
3. Remove the [Alignment Sensor Bracket on page 199](#).
4. After the sensor bracket is out, remove the (2) M4 nuts and the (2) washers located beneath the nuts

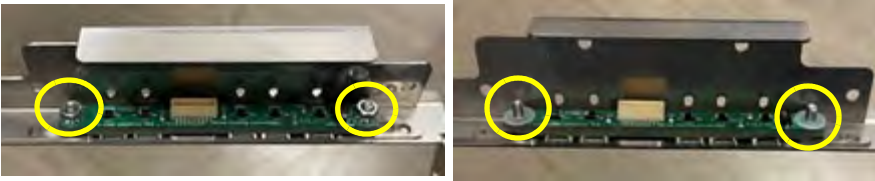

5. Remove the alignment sensor board.
- NOTE:** Make sure there are washers below the board. If there are not, you will need them when reinstalling.
6. Place the new alignment sensor board in position
 7. Install the (2) washers and tighten the (2) nuts.
 8. Connect the alignment sensor board connector.
 9. Push in the laminator drawer.
 10. Connect the power cord.
 11. Run [Sensors on page 11](#) to ensure the alignment board is fully functioning.
 12. Resume normal operation.

M1-7, M9 Motor Driver (Stepper Board)

Use this procedure for DRV M1, DRV M2, DRV M3, DRV M4, DRV M5, DRV M6, DRV M7, or DRV M9.

1. Remove the [Rear Cover on page 110](#).
2. Locate the appropriate motor driver.
3. Disconnect the (3) connectors.



4. Remove the (2) M4 screws and the driver and bracket assembly.



5. Disconnect the cables from the motor driver board.
6. Set the (5) dip switches on the new motor driver in accordance with the table to the right.

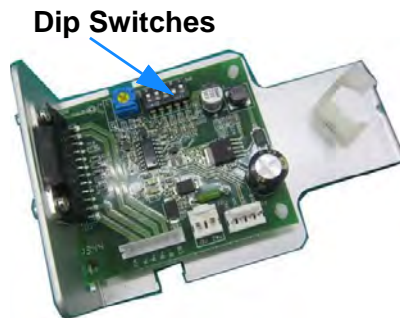

M1 Motor Driver		M2 Motor Driver		M3 Motor Driver	
1	Off	1	Off	1	Off
2	On	2	On	2	Off
3	Off	3	Off	3	On
4	On	4	On	4	Off
5	Off	5	Off	5	On
M4 Motor Driver				M5 Motor Driver	
1	Off			1	Off
2	Off			2	Off
3	On			3	On
4	Off			4	Off
5	On			5	Off
M6 Motor Driver		M7 Motor Driver		M9 Motor Driver	
1	Off	1	Off	1	Off
2	On	2	On	2	On
3	Off	3	Off	3	Off
4	On	4	On	4	Off
5	Off	5	Off	5	Off

7. Place the driver and bracket assembly in position and tighten the (2) M4 Screws.
8. Connect the (3) connectors.
9. Install the [Rear Cover on page 110](#).
10. Connect the power cord.

M8 Motor Driver (Stepper Board)

Use this procedure for DRV M8.

1. Perform the [M8 Motor Driver on page 189](#) repair procedure and stop at step 9 before removing the driver.
2. Check that the dip switches and drivers are set in accordance to the table and images below.

IMPORTANT: Turn dials 1, 2 and 3 back and forth slightly to ensure they click into place. They can appear to be set correctly, but even slightly out of position will cause slow driving.

3. Use a small flat head screwdriver to adjust any settings that do not match.

NOTE: If the M8 is not functioning correctly when the dials appear correct, change the setting to a different value, and then turn it back, ensuring the dial clicked into place.

Examples of incorrect functioning are the motor traveling in the wrong direction or at the wrong speed.

4. Install the driver following the install instructions for [M8 Motor Driver on page 189](#).

M8 Motor Driver		M8 Motor Driver Dials	
1	Off	Dial 1	5
2	On	Dial 2	F
3	Off	Dial 3	1
4	Off		
5	Off		
6	Off		

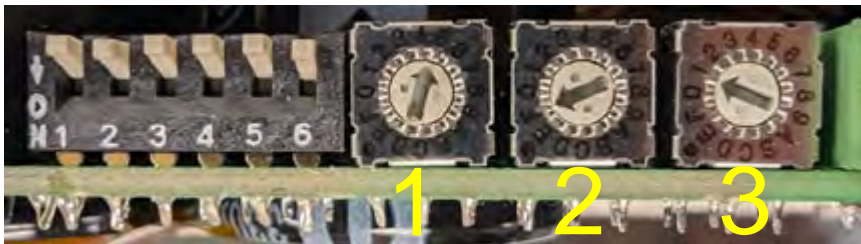

Solenoids

Solenoid #	Solenoid Type	Replacement Procedure
SOL1, SOL8	Diverter	page 160
SOL2	Entrance Idler, Top	page 161
SOL3	Entrance Idler, Bottom	page 161
SOL6	Cutter Clutch	page 164

Diverter (SOL1 and SOL8)

Remove

1. Remove the [Rear Cover on page 110](#).
2. When replacing solenoid 1 only, remove the bracket from the [Exhaust Fan on page 121](#).
3. Remove the (2) M4 screws from the diverter shaft.

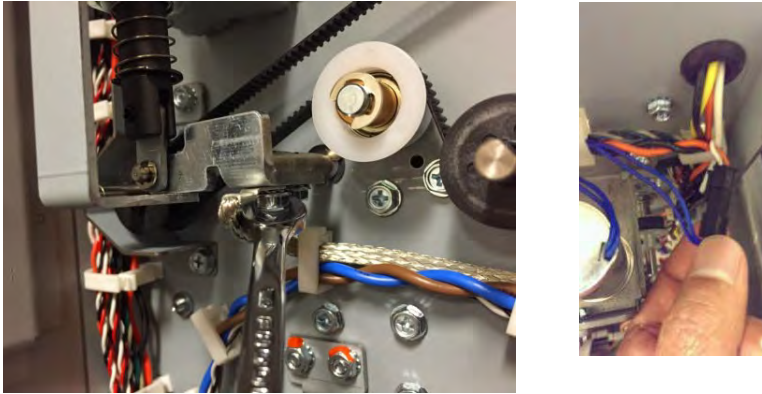

4. Disconnect the inline connector for the diverter solenoid sub-assembly.
5. Remove the (2) screws from the diverter solenoid sub-assembly.



6. Remove the diverter solenoid sub-assembly.



Install

1. Place the new solenoid in position and tighten the (2) screws to the rear frame and (2) screws to the diverter shaft.
2. Connect the inline connector for the diverter solenoid.
3. Place the cable into the cable clamps and close the cable clamps.
4. Do the adjustment for the [Diverter Solenoid \(SOL1\) on page 210](#) or [Trim Diverter Solenoid \(SOL 8\) on page 211](#).
5. Install the bracket for the [Exhaust Fan on page 121](#).
6. Install the [Rear Cover on page 110](#).
7. Connect the power cord.

Entrance Idler (SOL2 and SOL3)

1. [Undock the Laminator on page 110.](#)
2. Open the front door.
3. Disconnect the solenoid connector for the solenoid being replaced.

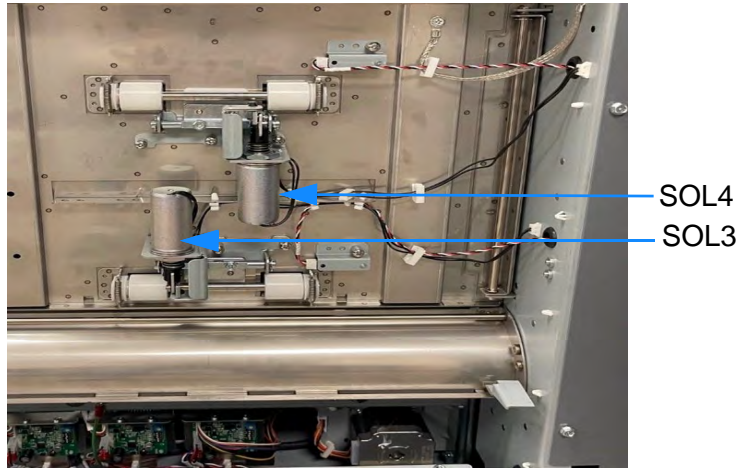

4. Open the cable clamps and remove the cable.
5. Remove the (3) M4 barrel screws and the solenoid assembly.
6. Place the new solenoid assembly in position and tighten the barrel screws.
7. Connect the solenoid connector.
8. Place the cable into the cable clamps and close the clamps
9. Close the front door.
10. [Dock the Laminator on page 111.](#)
11. Connect the power cord.

Anti-Static Brush

This part is located on the Upper Bypass Panel.

1. [Undock the Laminator on page 110](#) from the downstream equipment.

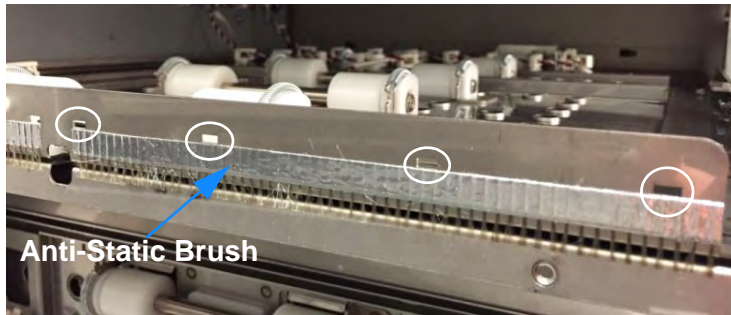

2. Peel off the old anti-static brush.
3. Clean the surface with some isopropyl alcohol.
4. Affix the new brush inside, referencing the cut-outs as shown above.
5. [Dock the Laminator on page 111](#) from the downstream equipment.
6. Connect the power cord.

Cutter Module

Motor

1. Remove the [Rear Cover on page 110](#).
2. Remove the (5) bolts using a 13mm wrench.

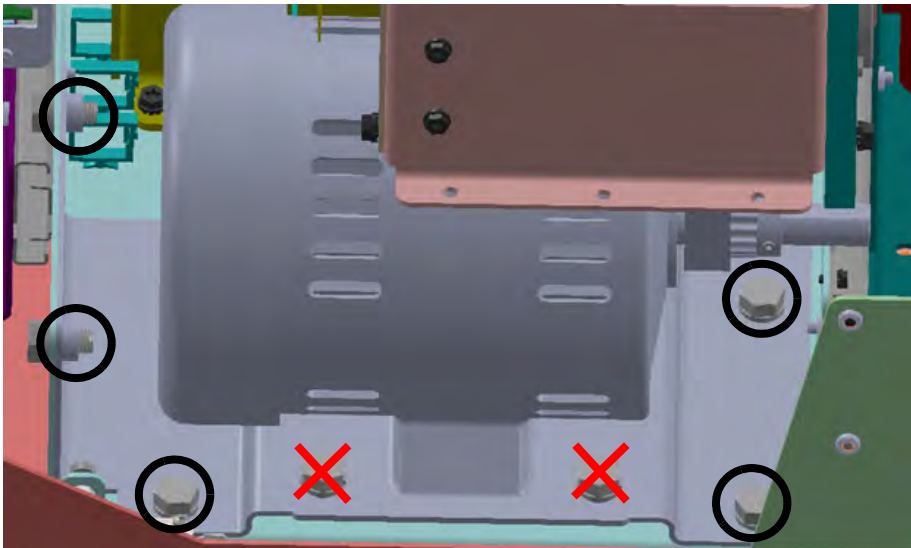

3. Lift the motor up and slip the belt off of the clutch pulley toward the cutter plate to remove the motor.
4. Install the new motor and place the belt around both pulleys.
5. Perform the adjustment for [Motor Belt Tension on page 228](#).
6. Tighten the (5) bolts.
7. Install the [Rear Cover on page 110](#).
8. Connect the power cord.

Belt

1. Remove the [Rear Cover on page 110](#).
2. Loosen the (5) bolts using a 13mm wrench.

IMPORTANT: Do not remove the bolts and do not loosen the bolts marked with red in the drawing below.

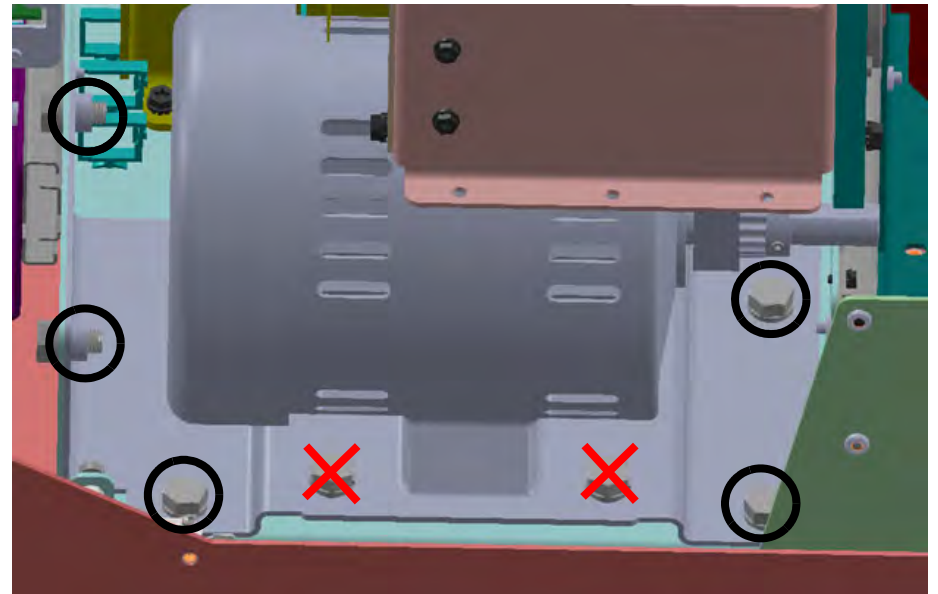

3. Lift the motor and slide the belt off the motor shaft.
4. Replace the belt.
5. Adjust the belt tension following instructions for [Motor Belt Tension on page 228](#)
6. Tighten the bolts.
7. Install the [Rear Cover on page 110](#).

Clutch

1. Remove the [Rear Cover on page 110](#).
2. Perform the belt removal procedure on [page 163](#) and return here once the belt is removed.
3. Lift the motor up and slip the belt off of the clutch pulley.
4. Use a 5mm hex wrench to remove the shoulder bolt from the crank.

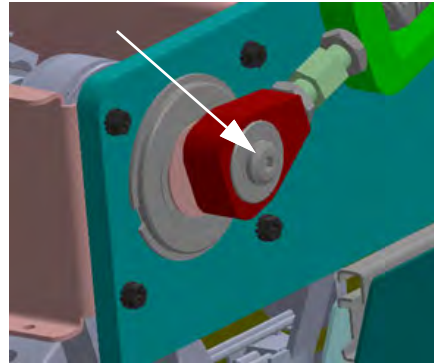

5. Gently lower the connecting rod while making sure the washer between the rod and crank does not fall into the machine. Remove the set screw securing the shaft to the crank.

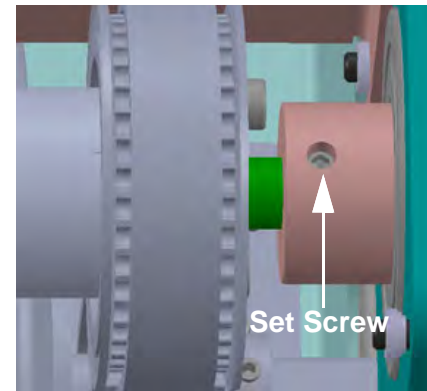
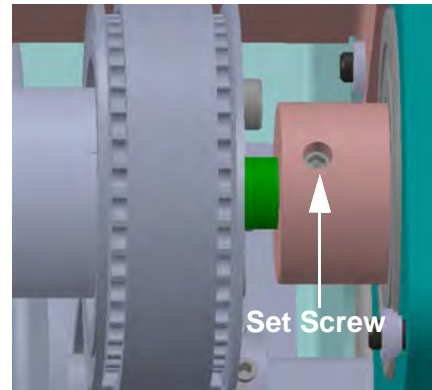

6. Remove the set screw securing the shaft to the crank.

7. Install and tighten the M6 bolt, supplied with the new clutch, with a wrench while supporting the clutch.

IMPORTANT: You may need to hold the pulley to prevent rotation.

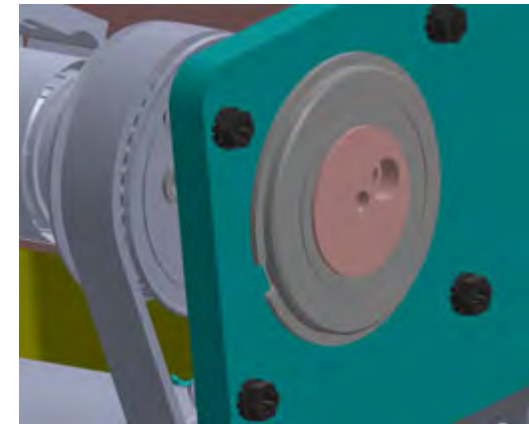

NOTE: As the bolt is tightened, the shaft will push out of the crank.

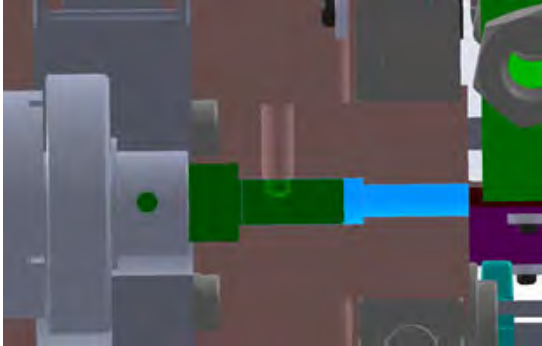

8. Once the shaft is free, remove the pulley from the old clutch and install it onto the new clutch and shaft assembly by removing the three socket head cap screws with a 5mm Allen wrench.
9. Install the new clutch and shaft assembly on the crank, ensuring that the set point on the screw is aligned with the set screw hole.
10. Apply blue thread locker when installing the set screw.
11. Follow [Belt on page 163](#), reinstall the belt, up to and including reinstalling the motor plate.
12. Apply red thread locker to the bolt, provided with the kit, and use to secure the connecting rod to the crank.

IMPORTANT: Place the washer between the bearing and crank.



13. Tighten the shoulder bolt until it is bottomed out.

There should be no room for the bearing assembly to move on the shoulder bolt.

IMPORTANT: To tighten the shoulder bolt fully, place a 7-10mm thick tool, such as an Allen wrench, between the cutter actuator and frame to prevent the cutter from moving through a stroke while you tighten it.

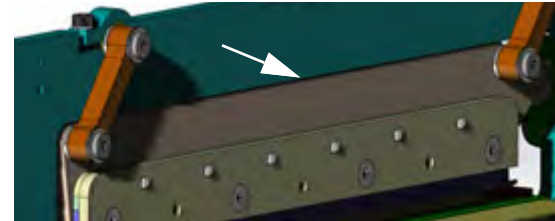

14. Wait one hour for the thread locker to dry.
15. Install the covers.
16. Connect the power cord.
17. Perform a cutter adjustment to confirm the cutter is cutting correctly (see [Cutter Module on page 228](#)).

Blade



CAUTION: Blade is sharp. Take care when handling.

This procedure outlines how to repair a loose blade assembly, which can cause issues with cutting until fixed.

1. Open the front door and pull out the lamination drawer.
2. Remove the [Locking Mechanism on page 195](#).
3. Test the rigidity of the blade assembly by carefully pushing/pulling it side-to-side. There should be no give or looseness. If the assembly feels loose, proceed to step 4.



4. Use a #10 socket to remove the (4) nuts on the rear of the two links.

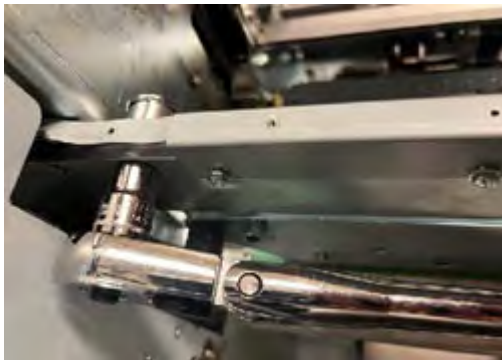

5. Beginning with the top two shoulder bolts, remove them using a #4 Allen wrench.

Use caution as the assembly will become disconnected from the frame.

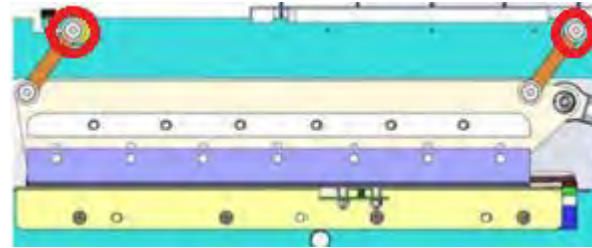

6. Add red Loctite to the thread of the shoulder bolts, then install the shoulder bolts until tight.



7. Install (2) of the nuts, while the Allen wrench holds pressure against the shoulder so the nuts do not loosen the shoulder bolt.
8. Repeat steps 5-8 with the lower (2) shoulder bolts.

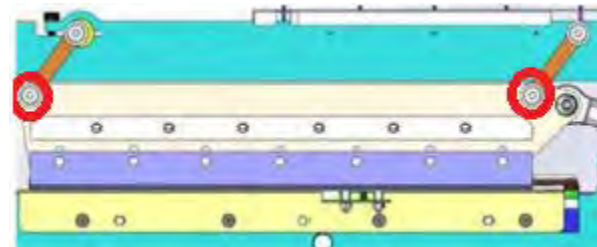

9. Confirm the blade assembly is tight and resistant to sideways motion.
10. Push in drawer, connect the power cord, and run some test cuts.
11. Check that double groove from [Cut Stick on page 46](#) inspection is no longer present.



CAUTION: Blade is sharp. Take care when handling.

This process outlines how to replace the blade.

1. Open the front door and pull out the lamination drawer.
2. Remove the [Locking Mechanism on page 195](#).
3. Attach the empty blade holder and align the (6) top pins holes. The magnets will hold the tool in place after fully inserted onto the pins.



4. Loosen the (4) allen head bolts and remove the (2) middle bolts. Leave the outer (2) allen head bolts loosely attached.



5. Use a flat head screwdriver to separate the plates (shown below).

NOTE: Newer versions will have a cut-out in between the plates to place the screwdriver. You may have to loosen the outer allen bolts further to create a larger gap.



6. Once the plates are separated remove the remaining outer (2) allen bolts while holding the black knobs with one hand.
7. Remove the tool with the blade and steel clamping plate together by using the two outer black knobs.



8. Set the old blade holder assembly on a table or other flat surface.

9. Locate the new blade assembly from the service kit.

The new blade assembly will look identical to the one you just removed, but will come with (4) new allen bolts and nuts through the pin holes that holds the assembly together.

There will also be one or two bolt and nut pairs along the top which temporarily secures the blade to the tool during shipping.

10. Remove all of the bolts from the new assembly but do **not** separate the parts.



11. Remove all the bolts from new assembly, but do **not** separate the parts.

12. Attach the (4) allen bolts from the old blade assembly with the new nuts from the new blade assembly to the old blade assembly.

Place the one or two bolt and nut pairs through the top pin holes to secure the tool to the assembly.

The old blade assembly can now be disposed of safely.

13. Inspect the new blade assembly to be sure blade is positioned correctly.

If incorrect, use caution and wear personal protective equipment to remove blade and position correctly.

Strong magnets hold this assembly together.



14. Attach new assembly to machine by aligning the top (6) pin holes and securing in place with the (4) new allen bolts.

Alternate tightening the four bolts to bring the blade assembly in evenly. Refer to step 3 and 4 for images.

15. When the bolts are snug, but **not** fully tightened, remove and discard the blade holder.

16. Install the [Locking Mechanism on page 195](#).

17. Push in drawer, close the door, and connect the power cord.

18. Power up the machine and using the LCD interface, [Cycle Cutter](#) by referring to [User Functions on page 8](#).

19. Power down the machine, remove the plug from the outlet, open the door and pull out the lamination drawer.

20. Fully tighten the (4) allen bolts on the blade assembly.

NOTE: Lower the locking mechanism, if needed, to access the middle bolts.

21. Push in drawer, close the door, and cycle power on the machine.

22. Reset the blade count to zero (see [Cutter Blade on page 11](#)).

Cutter Shaft Ball Bearing

1. Remove the [Rear Cover on page 110](#).



2. Remove the E-ring.
3. Remove the nylon washer.
4. Remove the ball bearing.
5. Place the new ball bearing in position.
6. Place the nylon washer in position.
7. Place the E-ring in position.
8. Install the [Rear Cover on page 110](#).
9. Connect the power cord.

Cutter Encoder

1. Remove the [Rear Cover on page 110](#).
2. Remove the (2) screws on the sensor bracket using a 5.5mm driver.

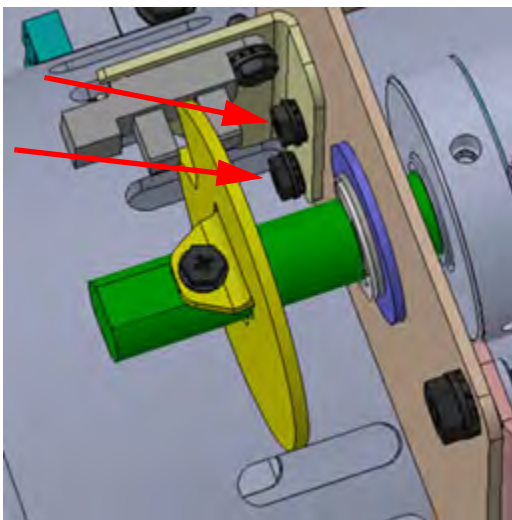

3. Use a Phillips screwdriver to remove the M3 screw securing the encoder and pull the encoder off of the shaft.

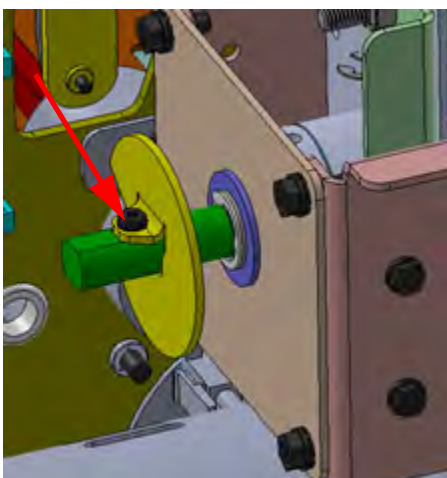

Install

NOTE: The cutter must be in the home position when installing the new encoder. Ensure that the AC cutter motor rotates freely and the clutch is indexed correctly before starting. See the [Motor Belt Tension on page 228](#) and [Clutch Indexing on page 229](#) to confirm.

1. Slide the encoder onto the shaft with the tab oriented as shown. The cutter must be in the position shown.

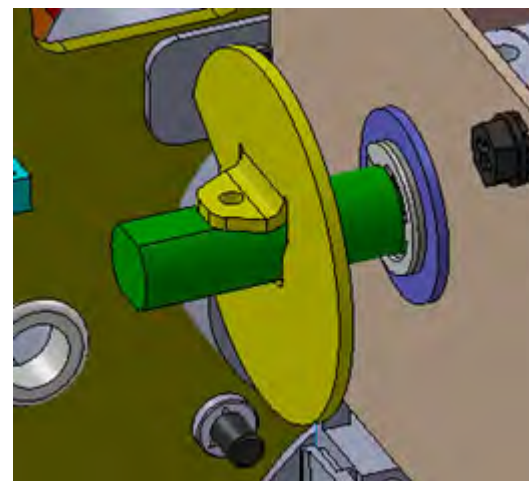

2. Apply blue threadlocker to the M3 screw provided with the encoder and secure the encoder in place. Do not fully tighten the screw.
3. Install the sensor bracket using a 5.5mm driver to tighten the (2) screws.
4. Confirm that the encoder is centered in between the sensor veins and tighten the M3 screw the rest of the way.

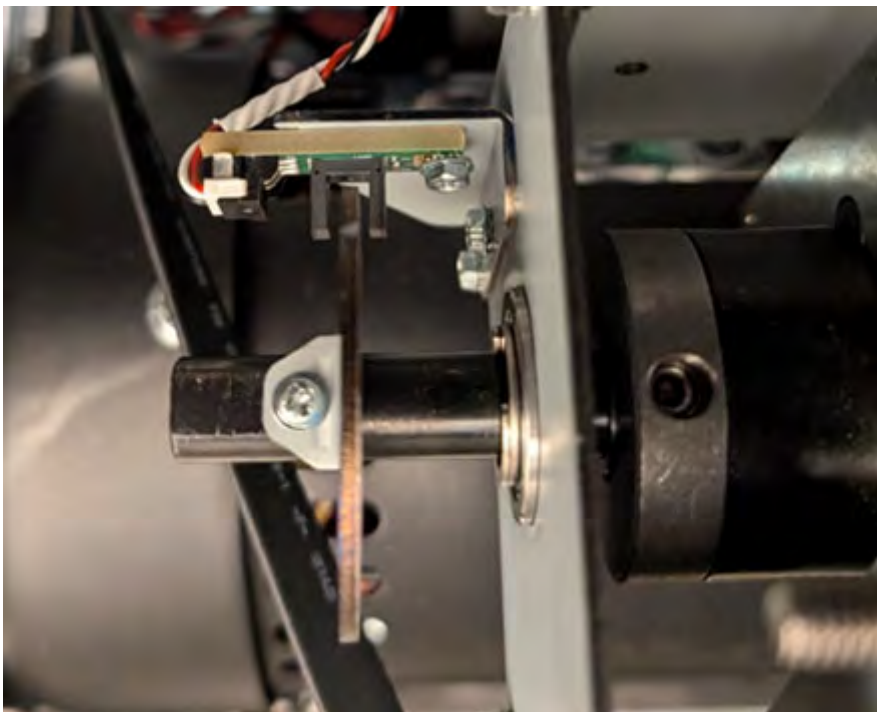

5. Wait 30 minutes for the threadlocker to cure before running the cutter.
6. Install the [Rear Cover on page 110](#).
7. Connect the power cord.

Trim Tray

Trim Tray Home Switch

1. Open the front door.

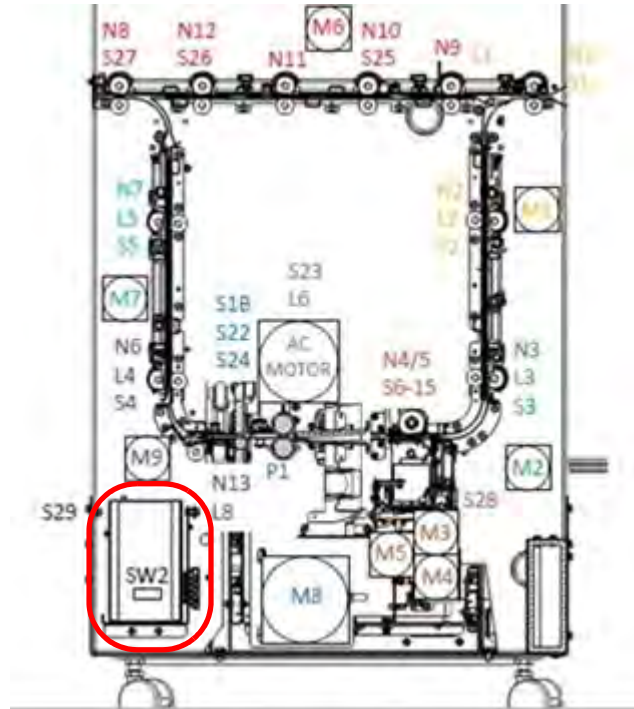

2. Remove the trim tray.

3. Disconnect cable (7725565) at the trim tray home switch.



4. Remove the (2) screws and the old trim tray home switch bracket.
5. Place the new bracket in position and tighten the screws.
6. Connect cable at the trim tray home switch.
7. Put the trim tray in position and push in firmly until it latches.
8. Close the front door.
9. Connect the power cord.

Trim Level Emitter

1. Open the front door.
2. Remove the trim tray.
3. Locate the trim level emitter on the frame at the left (downstream) side of the trim tray compartment.
4. Disconnect cable at the trim level emitter.



5. Remove the (2) screws and the old trim level emitter.
There will be (4) washers between the sensor and the sheet metal bracket.
6. Place the new emitter, and the washers, in position and tighten the screws.
7. Connect the cable to the emitter.
8. Put the trim tray in position and push in firmly until it latches.
9. Close the front door.
10. Connect the power cord.

Trim Level Receiver

1. Open the front door.
2. Remove the trim tray.
3. Locate the trim level receiver on the frame at the right (upstream) side of the trim tray compartment.
4. Disconnect cable at the trim level receiver.

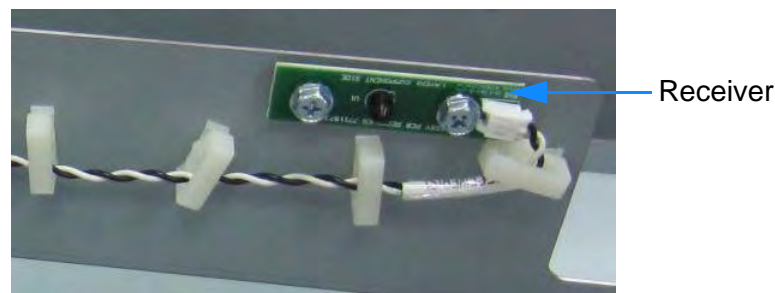

5. Remove the (2) screws and the old trim level receiver.
There will be (4) washers between the sensor and the sheet metal bracket.
6. Place the new receiver, and the washers, in position and tighten the screws.
7. Connect the cable to the receiver.
8. Put the trim tray in position and push in firmly until it latches.
9. Close the front door.
10. Connect the power cord.

Steering Module

Alignment Module

1. Power off the machine and unplug from the outlet.
2. Open the door and pull out the laminator drawer.
3. Locate the alignment module.

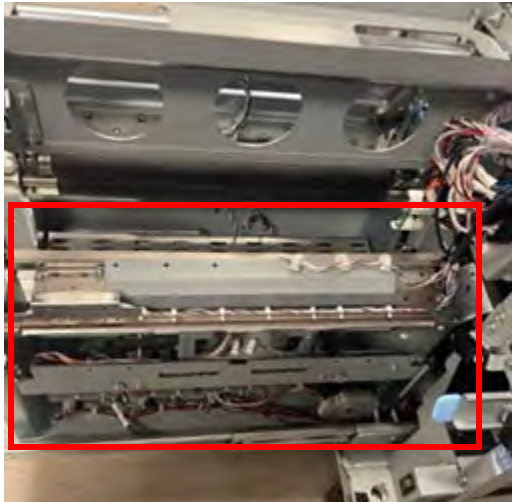

4. Disconnect and unclamp the skew and alignment board cables and gently move them away from the alignment module.

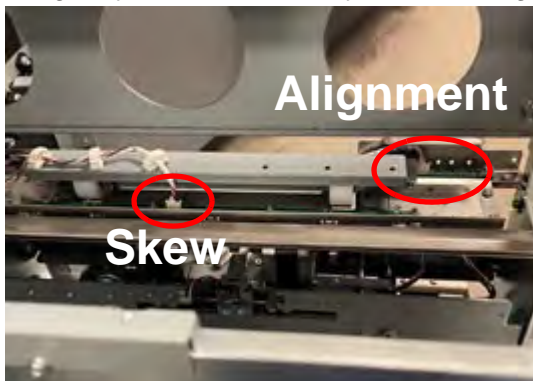

5. Locate and disconnect M3 & M4 Driver board cables and remove the grounding strap.

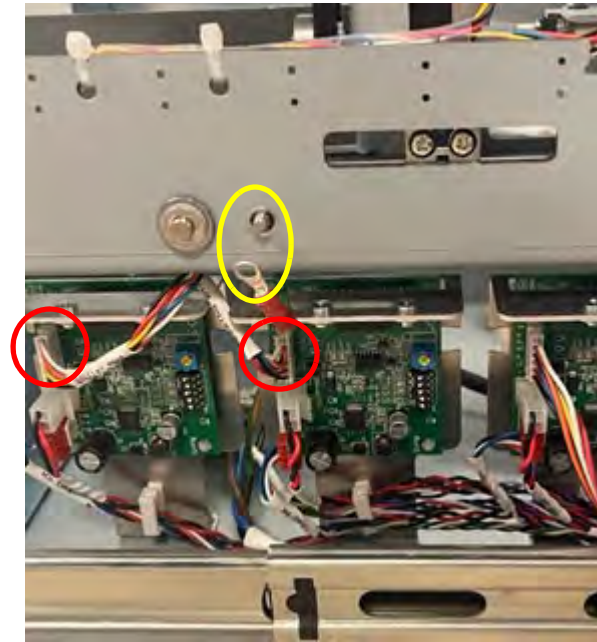

6. Remove the [Alignment Sensor Bracket on page 199](#).
7. Locate and disconnect the S28 alignment home sensor and remove it from the wire harnesses.



8. Carefully tuck the S28 cable beneath the alignment module.



9. Remove the (4) 7mm screws located at the front and the (4) screws at the rear of the laminator drawer.

NOTE: Alignment module will drop down when all screws are removed.

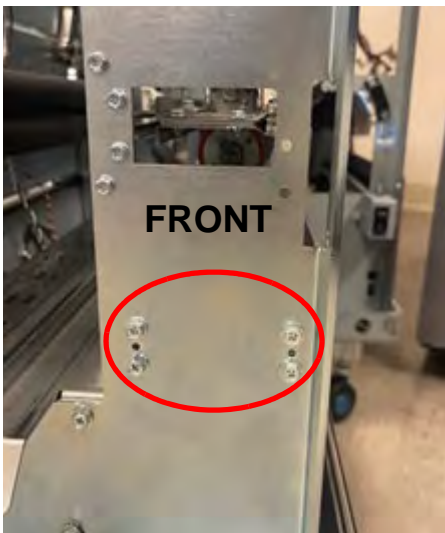

10. After removing all screws, hold the alignment module until the toothed belt becomes loose then remove it from the pulley.

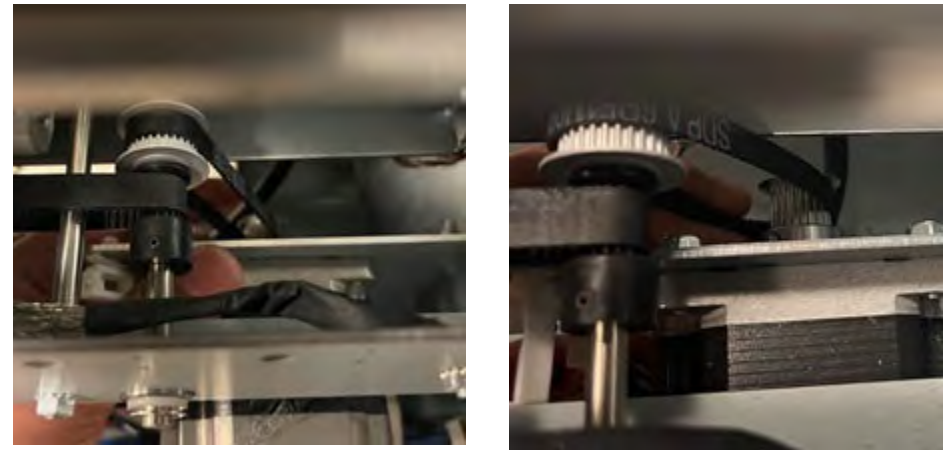

11. Hold the module by the base then pull up and out.



Laminator Alignment Stepper Motor, Pulley and Bracket

Use this procedure for the alignment stepper motor (M5) and pulley, or the alignment stepper mount bracket.

1. Open the front door.
2. Pull out the laminator drawer.
3. Remove the [Cartridge Rail Plate on page 192](#).

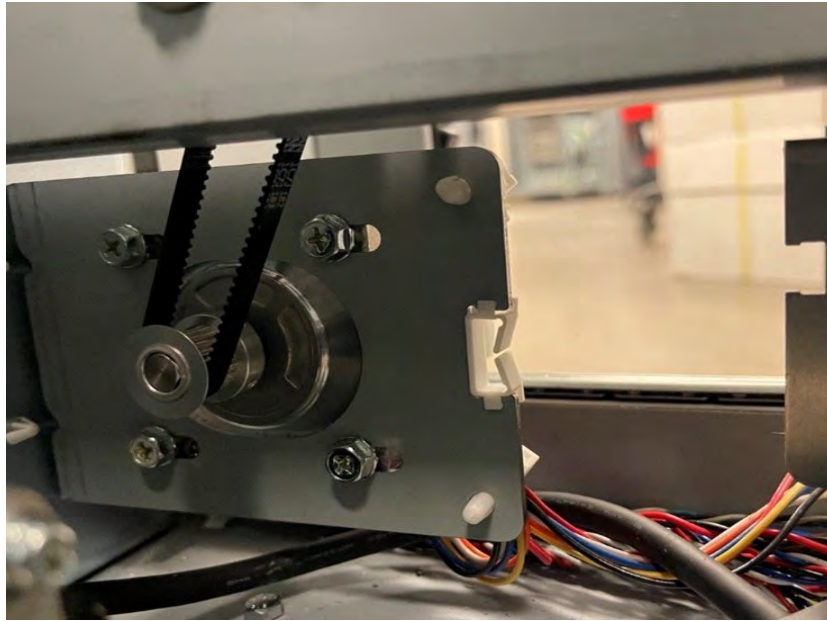

4. Remove the (4) Phillips screws and the timing belt.
5. Replace the alignment stepper mount bracket by removing the (2) screws holding the bracket.
6. Place the new bracket in position and tighten the screws.

7. Remove the stepper motor and pulley.
8. Place the timing belt around the pulley.
9. Adjust the tension on the belt.
10. Tighten the (4) Phillips screws.
11. Install the cartridge rail.
12. Push in the laminator drawer.
13. Close the front door.
14. Connect the power cord.

Alignment Carriage Sub-Assy

Remove

1. Remove the [Alignment Module on page 174](#).
2. Remove the steering idler and drive panel assemblies by removing the (4) M3 nuts.

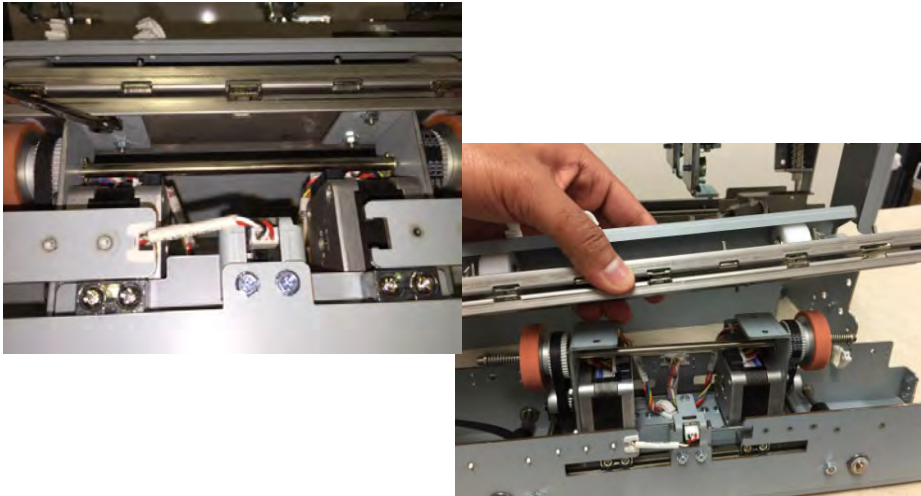

3. Remove (4) E-clips from steering drive roller shaft.

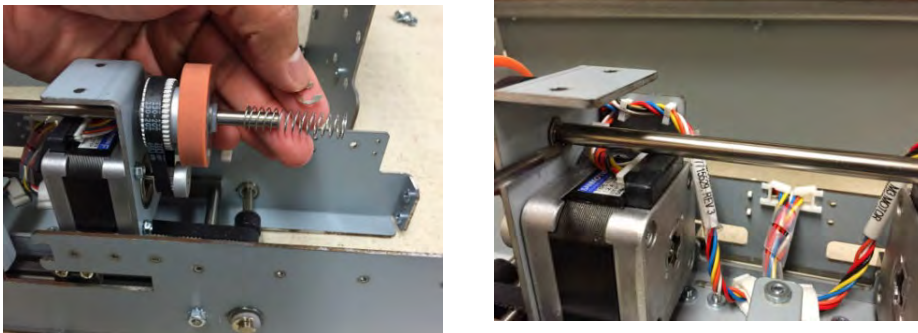

4. Remove the drive roller shaft and all of the components (4 plastic washers; 2 springs; 2 drive rollers; 2 belts; 4 e-clips) on the drive shaft.

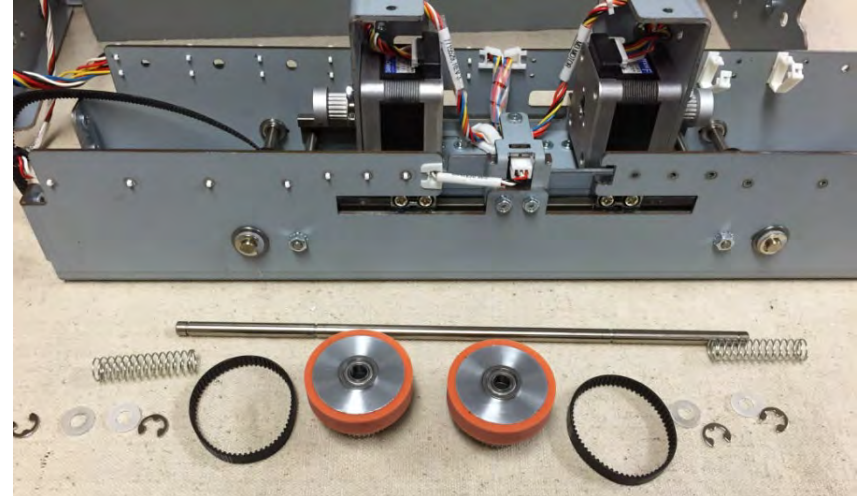

5. Remove the align home sensor bracket sub-assembly by removing the (2) screws and its cable.

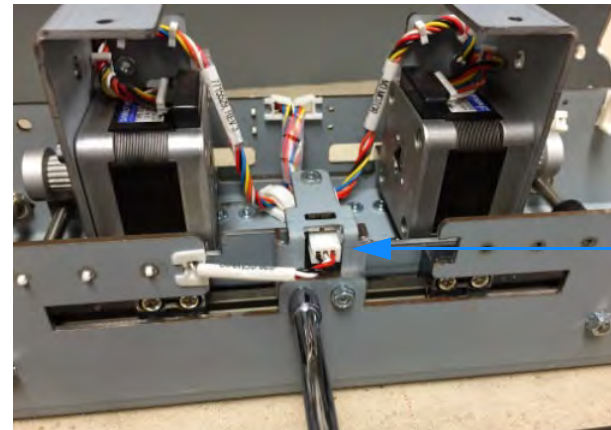

Align Home Sensor Bracket

6. Remove left and right steering stepper motors, along with their corresponding cables, by removing the (8) screws.

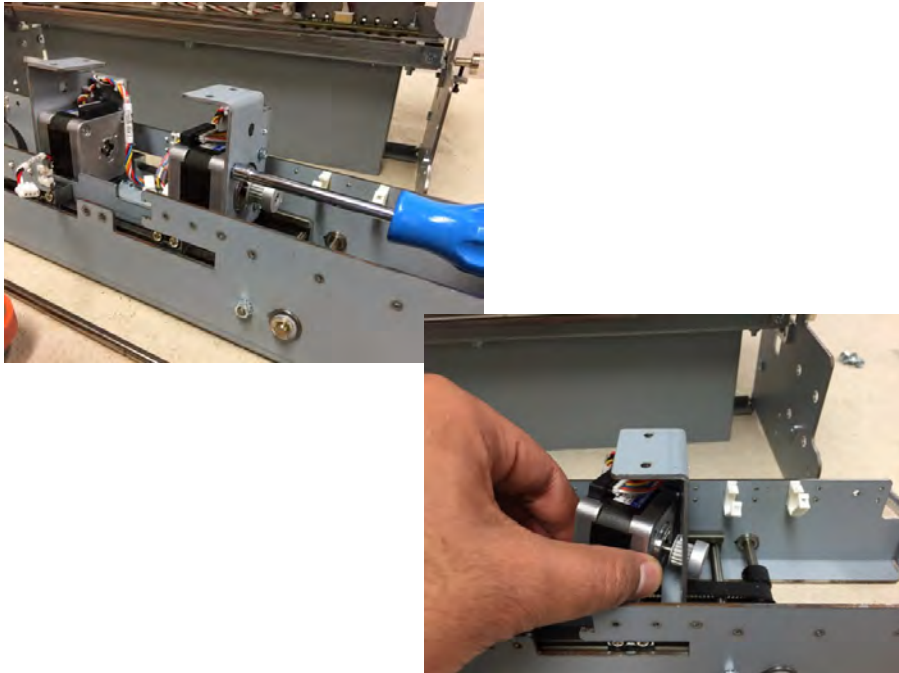

Installation Tip: Look at the images for selecting the proper cable for the motors:

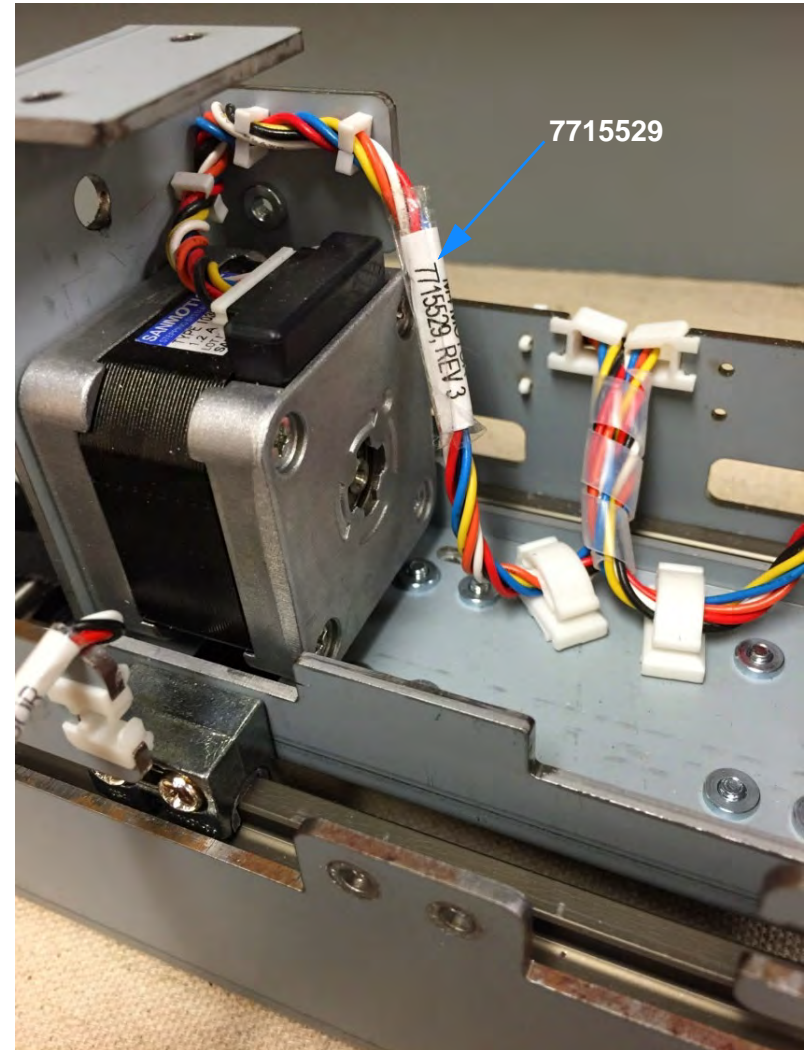

Install

1. Install the parts that were removed in the new alignment carriage sub-assembly.

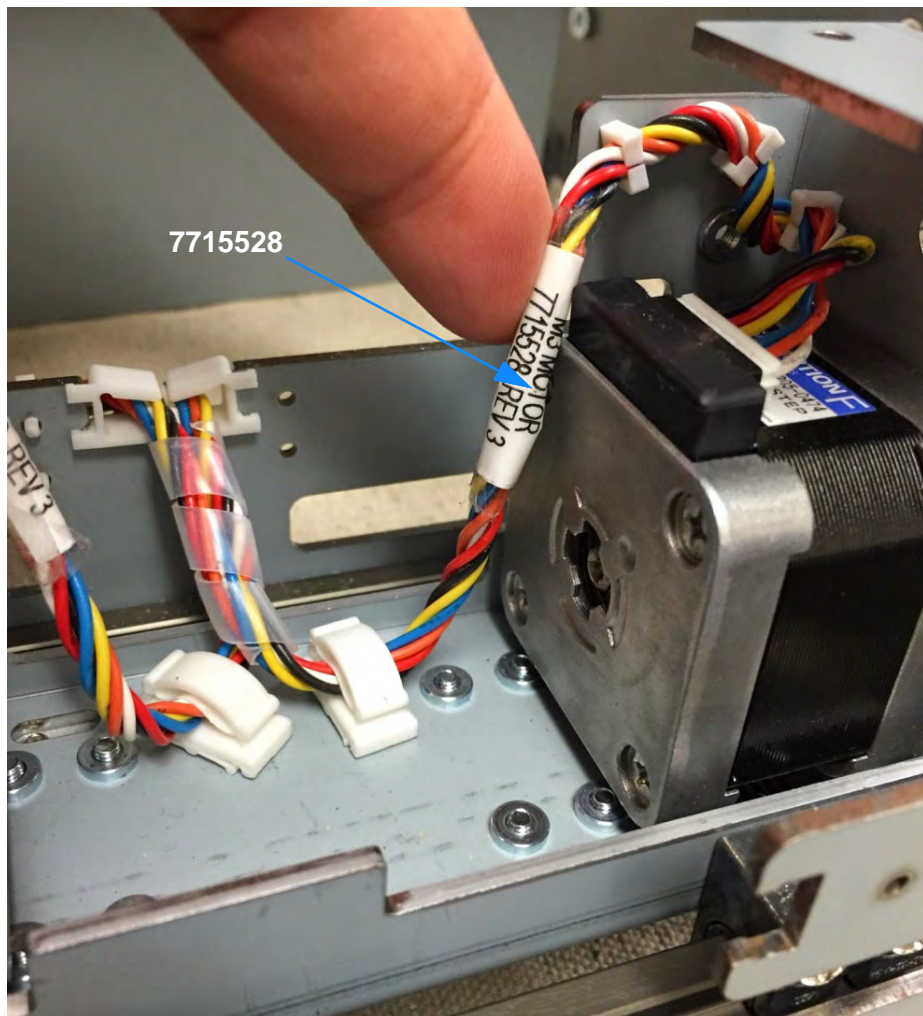

2. Install the [Steering Module on page 174](#).
3. Push in the laminator drawer.
4. Install the [Rear Cover on page 110](#).
5. Connect the power cord.

Steering Stepper Motor

Use this procedure for the front/left stepper motor (M3) or the rear/right stepper motor (M4).

Remove

1. Remove the [Alignment Module on page 174](#).

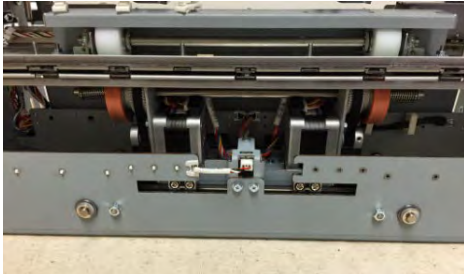

Remove the rear side steering motor, the [Steering Module on page 174](#) needs to be removed.

2. Disconnect the steering motor cable at the motor and at the header.

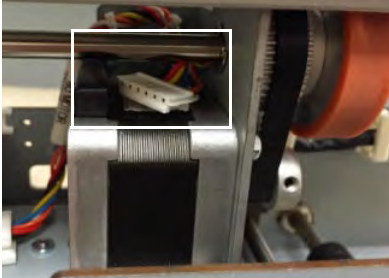

3. Remove the (2) M3 screws and the align home sensor bracket to create more room.

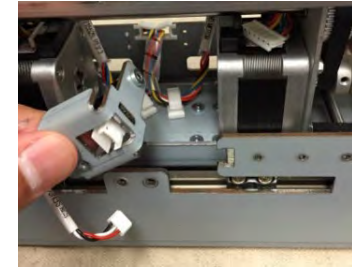

4. Remove the (4) M3 Phillips screws.

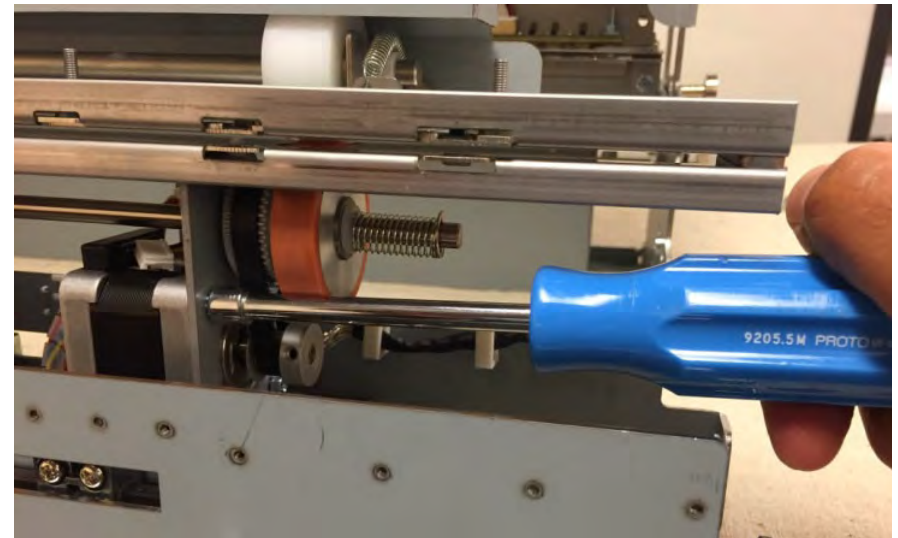

Steering Motor Belt (65 Groove)

Remove

Use this procedure for the 65 groove steering belt, the steering drive roller assembly or the steering drive roller spring.

1. Remove the [Alignment Module on page 174](#).
2. Remove the E-ring from the steering drive roller shaft from the side that needs to be replaced and the two E-rings inside the bracket.

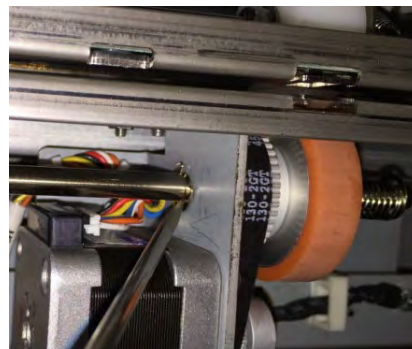
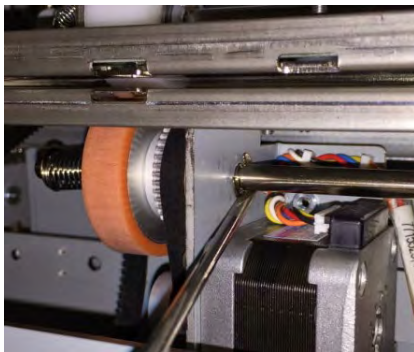
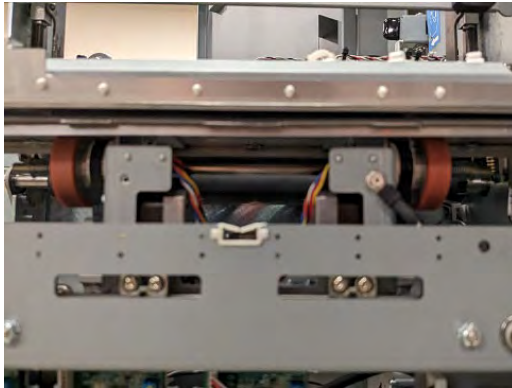

3. Slide the shaft in the opposite direction so that the (2) steering drive roller springs, plastic washers and steering drive roller can be removed (from the side that needs the part replaced).

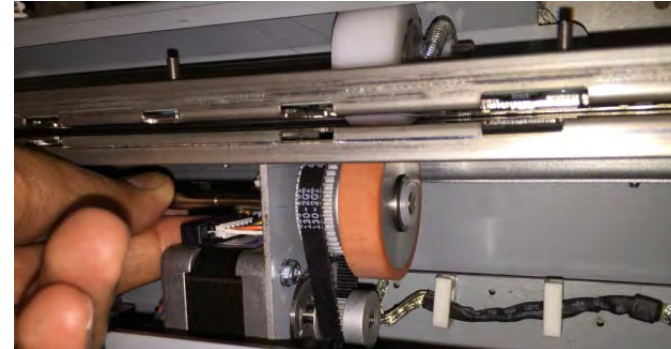

With the above parts removed, one or more of the following parts can be replaced:

- 65 Groove Steering Belt
- Steering Drive Roller
- Steering Drive Roller Spring



Install

1. Place the belt around the timing pulley.
2. Install the steering drive roller and the (2) flat washers and the spring on the end of the shaft.
3. Install the E-rings on the steering drive roller shaft.
4. Push in the laminator drawer.
5. Connect the power cord.

Steering Drive Roller Shaft

1. Remove the [Alignment Module on page 174](#).
2. Remove the (2) E-rings, the spring, the steering drive roller and the (2) flat washers from each end of the shaft.

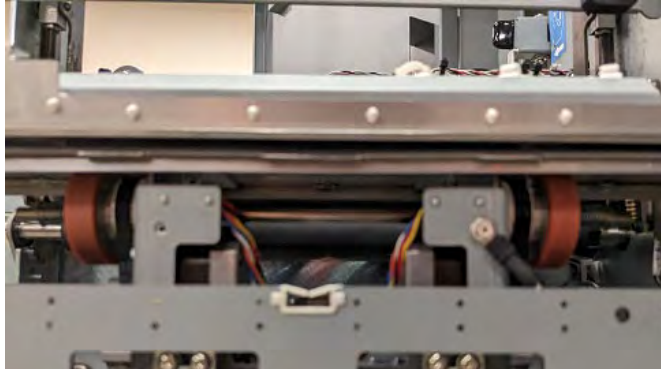

3. Remove the shaft from the drive panel steering sub-assembly.

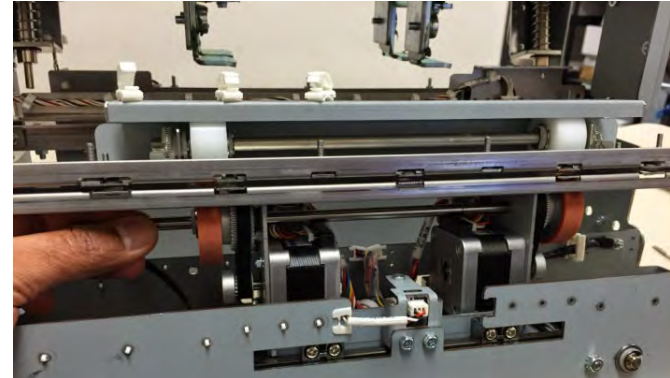

4. Place the new shaft into the drive panel steering sub-assembly.
5. Install the (2) E-rings, spring, steering drive roller and the (2) flat washers on each end of the shaft.
6. Install the [Steering Module on page 174](#).
7. Push in the laminator drawer.
8. Connect the power cord.

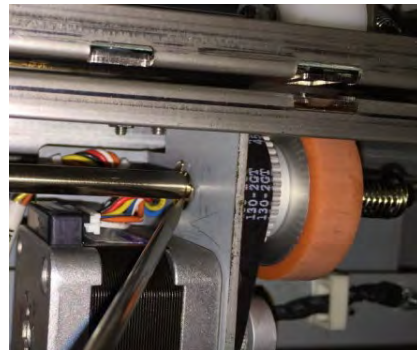
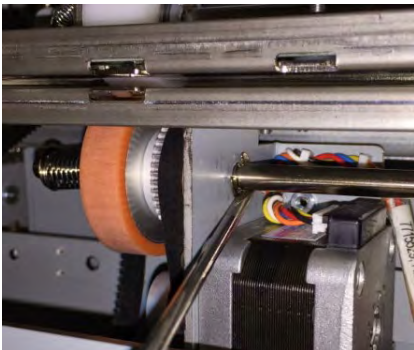

Steering Idler Panel Weldment

Remove

1. Remove the [Alignment Module on page 174](#).
2. Unplug the skew sensor and release the cable clamp.



3. Remove the (4) screws that hold the steering idler panel sub-assembly to the drive panel steering sub-assembly.

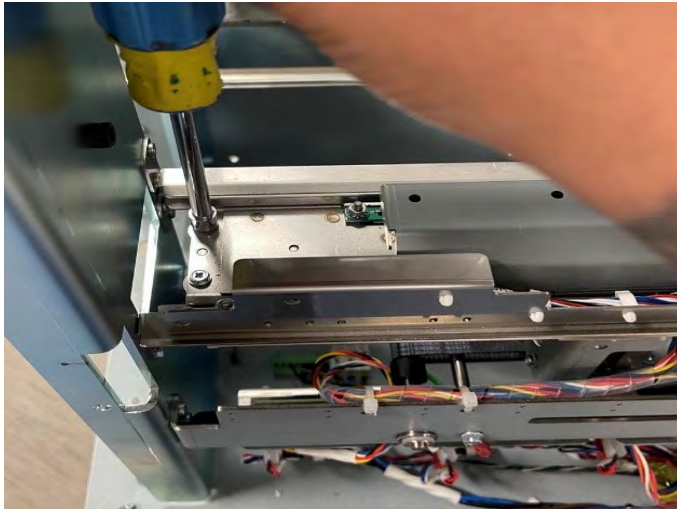

4. Remove the steering idler panel sub-assembly.



5. Keep track of the spacers on either end of the drive panel.

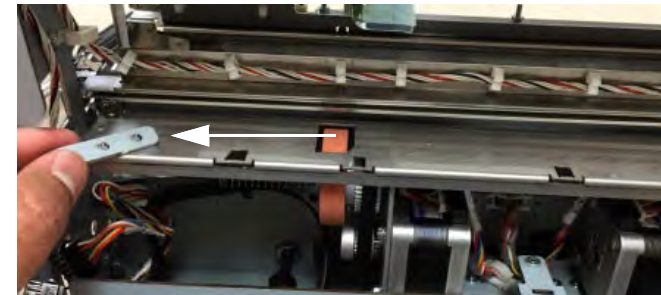

6. Transfer the skew sensor, steering idler roller, idler roller cover, and all fasteners to the new weldment.

NOTE: There is one nylon washer below and above the sensor board at each of the four locations.

Install

1. Make sure the (2) spacers are in position on the steering drive panel weldment (use semi perfs for placement).
2. Place the steering idler panel sub-assembly in position on the drive panel steering sub-assembly.
3. Install the (4) screws.
4. Push in the laminator drawer.
5. Connect the power cord.

Steering Idler Roller Assembly

Remove

1. Power off the machine and unplug from the outlet.
2. Open the front door.
3. Pull out the laminator drawer.
4. Disconnect the skew sensor board connector.

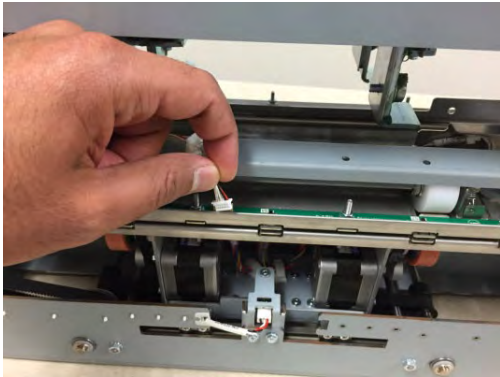

5. Release the cable clamp and move the cable out of the way.
6. Remove the (2) M4 Nuts.

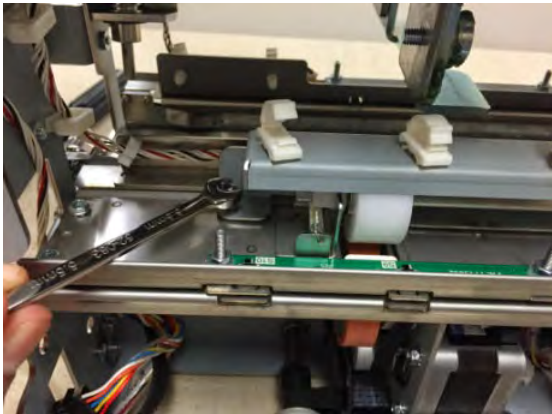

7. Remove the roller cover.

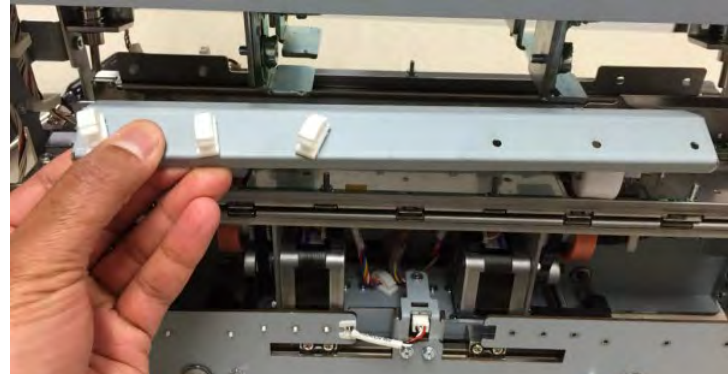

8. Gently move the (2) springs off the ends of the roller.

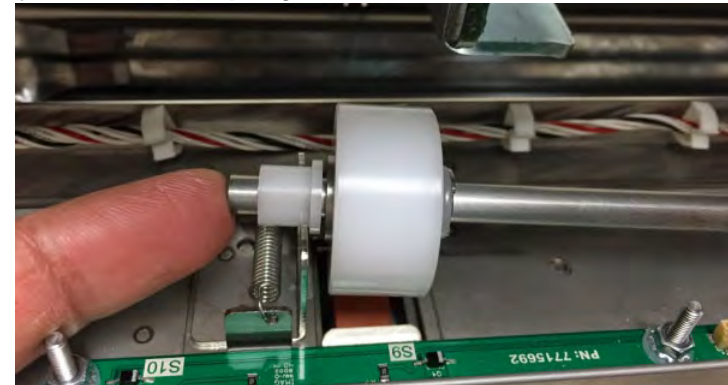

9. Remove the roller assembly.

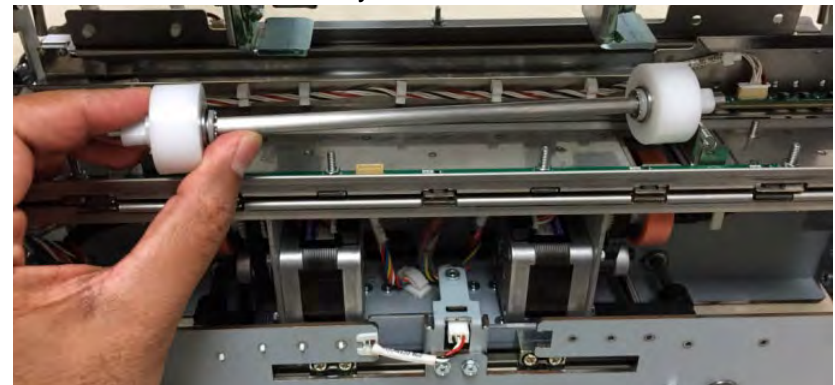

Install

1. Place the new idler roller assembly in position.
2. Gently move the (2) springs on to the ends of the roller.

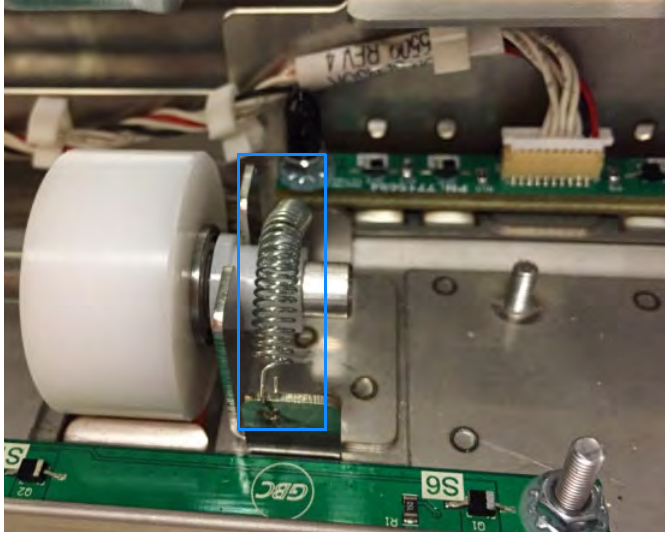

3. Ensure the springs are over the white roller bushings.
4. Place the roller cover in position.
5. Install and tighten the M4 Nuts.
6. Place the skew sensor board cable in the cable clamp and close.
7. Connect the skew sensor board connector.
8. Push in the laminator drawer.
9. Connect the power cord.

Steering Idler Roller Bearing

Use this procedure for the steering idler roller double "D" flange bearing.

1. Remove the [Steering Idler Roller Assembly on page 185](#).

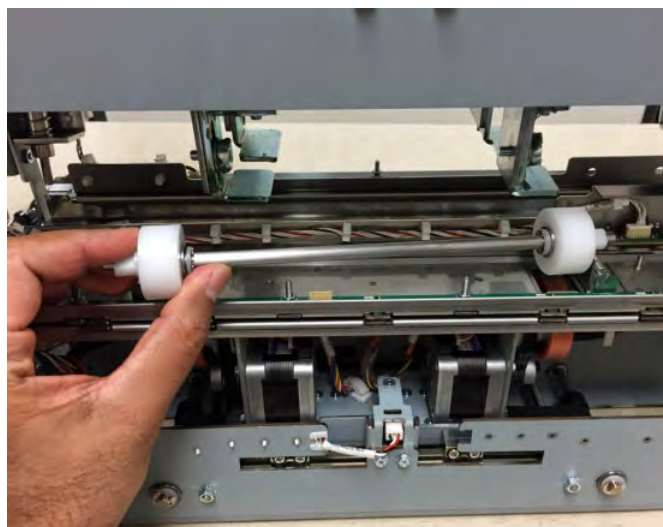

2. Remove the (2) steering idler roller bearings from the ends of shaft on the steering idler roller assembly.

Roller Bearing

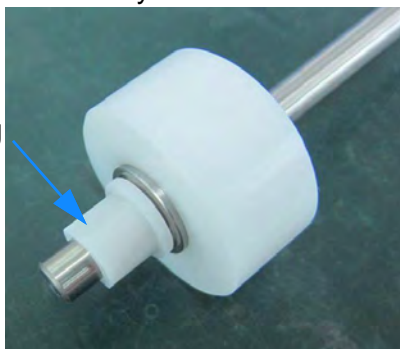

3. Place the new steering idler roller bearings on to the ends of shaft .
4. Replace the [Steering Idler Roller Assembly on page 185](#).

Steering Drive Panel Weldment

Remove

1. Do steps 1-5 in the removal of the [Steering Idler Roller Assembly on page 185](#).



2. Remove the (2) spacers.

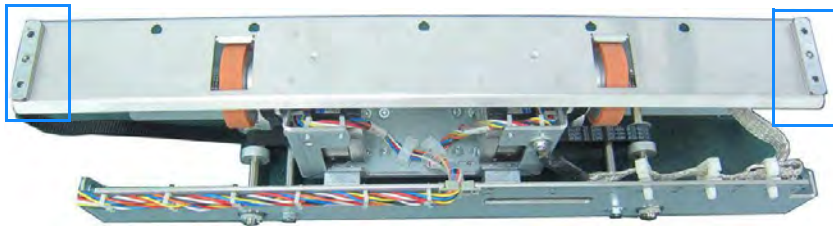

3. Remove the (4) nuts holding the steering drive panel weldment.

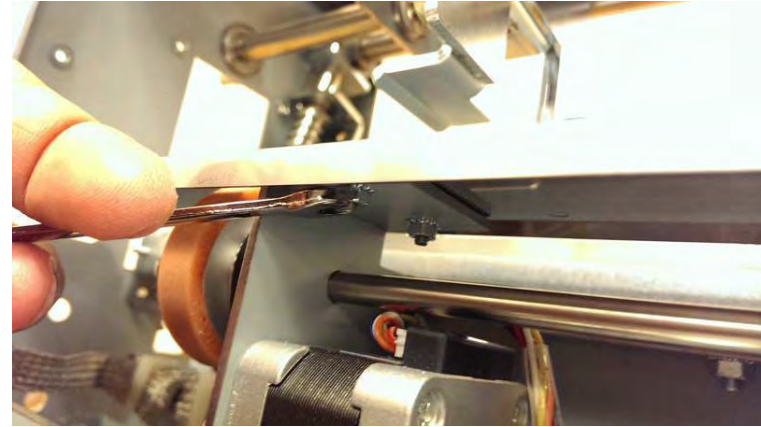

4. Replace with new part.

Install

1. Place the steering drive panel weldment in place.
2. Tighten the nuts that hold the weldment.
3. Install the spacers.
4. Install the [Steering Idler Roller Assembly on page 185](#).
5. Connect the power cord.

Laminator Module

M8 Motor Driver

1. Power off the machine and unplug from the outlet.
2. Open the front door.
3. Pull out the laminator drawer.
4. Use a 7mm driver to remove the (4) screws holding in the cartridge rail plate and then lift the plate out and set it aside.

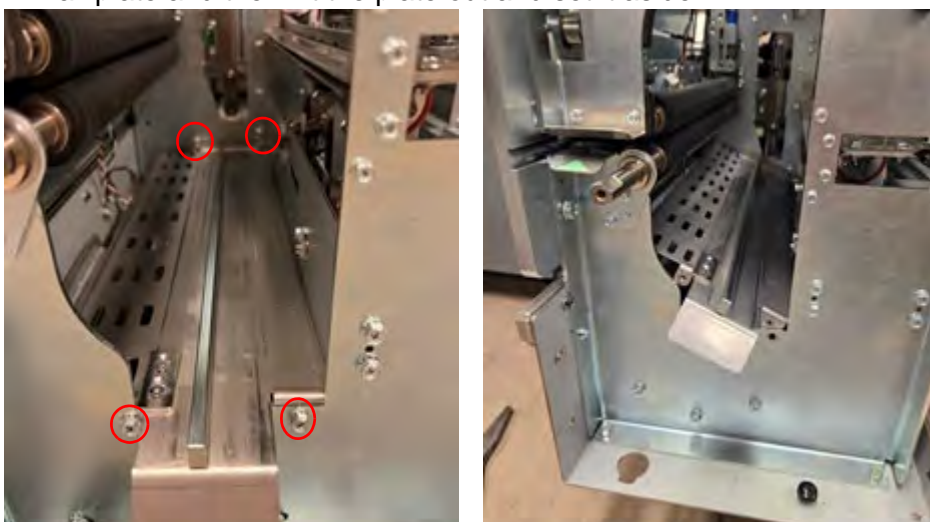

5. Unplug all (4) cables from the driver board.



6. Remove the (3) screws in the front using an 8mm driver.



7. Slide the driver plate assembly towards the aligner mechanism.



8. Rotate the assembly clockwise 270° to orient it for removal.

IMPORTANT: Do not try to rotate it counter clockwise. It will not fit and may cause damage to the machine.



9. Confirm that the locking mechanism is in the down position before lifting out the assembly.

10. Lift the assembly out by rotating it slightly counterclockwise around the pressure roller.

Once the assembly has cleared the top roller, you can lift the locking mechanism to create more space to remove the driver.

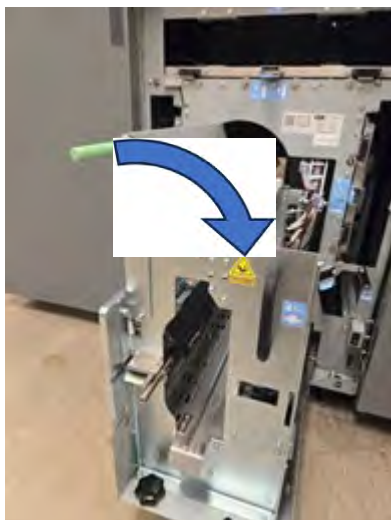
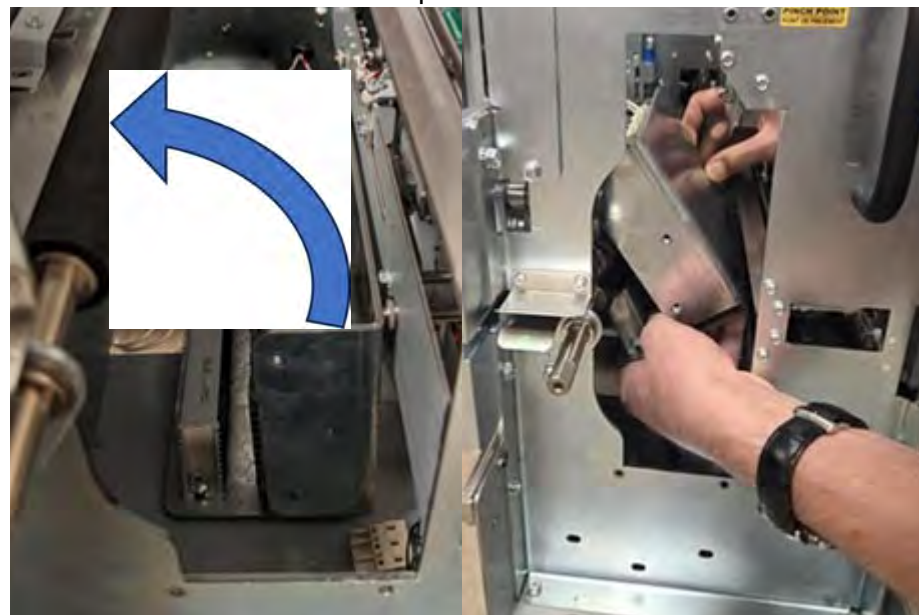

Install

1. Before installing the M8 motor driver, check the dip switch and dial settings are correct, see [M8 Motor Driver \(Stepper Board\) on page 158](#).
2. Open the front door.
3. Pull out the laminator drawer.
4. Close the locking mechanism lever to lower the pressure roller.
5. Lower the driver into the lamination drawer in the orientation shown below. You will need to rotate it as you lower it in to clear the pressure roller.

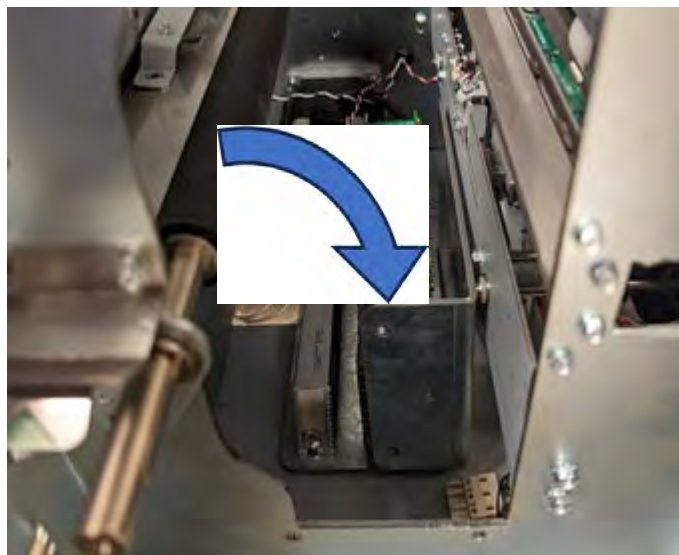

6. Rotate the assembly 270° counterclockwise until the resistor is on top.

IMPORTANT: Do not try to rotate it clockwise. It will not fit and may cause damage to the machine.

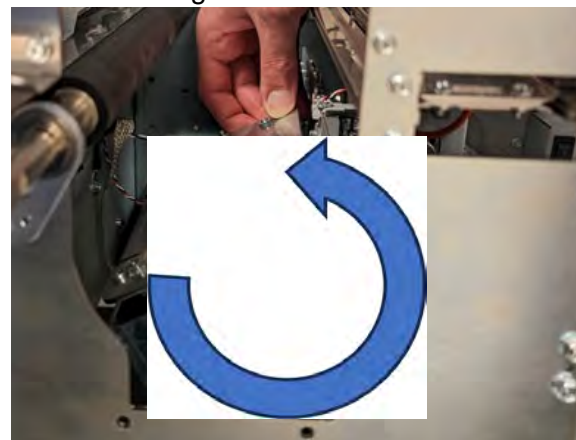

7. Once the assembly is in the correct rotation, plug the (4) cables into the driver.
8. Align the plate with the three holes and replace the (3) 8mm screws at the front of the lamination drawer.
9. Place the cartridge rail plate back into the machine.

NOTE: If the plate does not drop in easily, you will need to press or tap the flange tabs in to get them inside the frame.



Cartridge Rail Plate

1. Power off the machine and unplug from the outlet.
2. Open the front door.
3. Pull out the laminator drawer.
4. Use a 7mm driver to remove the (4) screws holding in the cartridge rail plate and then lift the plate out and set it aside.

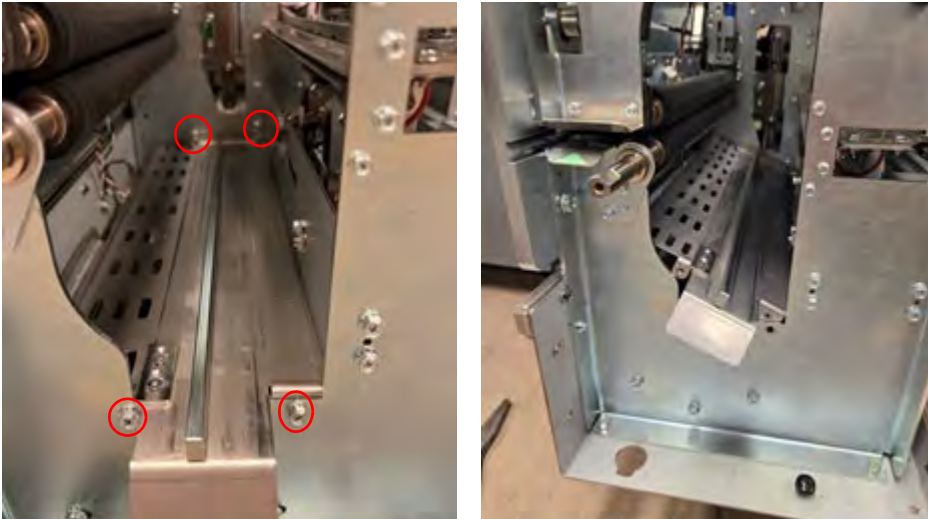

NOTE: After installing the new cartridge rail, adjust the [Rail Height on page 215](#).

Rollers

Lower

1. Open the front door and pull out the lamination drawer.
2. Remove the [Locking Mechanism on page 195](#).
3. Push the laminator drawer back in.
4. Remove the [Rear Cover on page 110](#).
5. Loosen the belt idler pulley on the shaft.
6. Loosen the (2) set screws on the pulley.



7. Remove the belt from the pulley.



8. Remove the pulley from the shaft.



9. At the front of the machine, pull out the laminator drawer and remove the (2) 7mm screws.



10. Pull the roller straight out.



11. Remove the E-ring, spacer, wave washer and bracket from the old shaft and place on the new one.



Pressure

12. Remove the infeed, cutter, and upper assembly baffle.

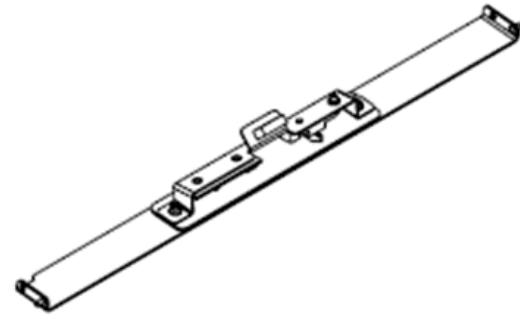

13. Pull out the toggle clamps, being careful not to lose washers, and replace the roller.



14. Perform the steps in reverse order to install the new rollers.

15. Check the spring pressures are correct according to the adjustment for [Locking Mechanism Springs on page 237](#).

16. Install the [Rear Cover on page 110](#).

17. Connect the power cord.

Locking Mechanism

Remove

1. Open the front door.
2. Remove the cartridge.
3. Pull out the lamination drawer.
4. Locate the front and rear bracket and remove the (2) 8mm screws and set the brackets aside.

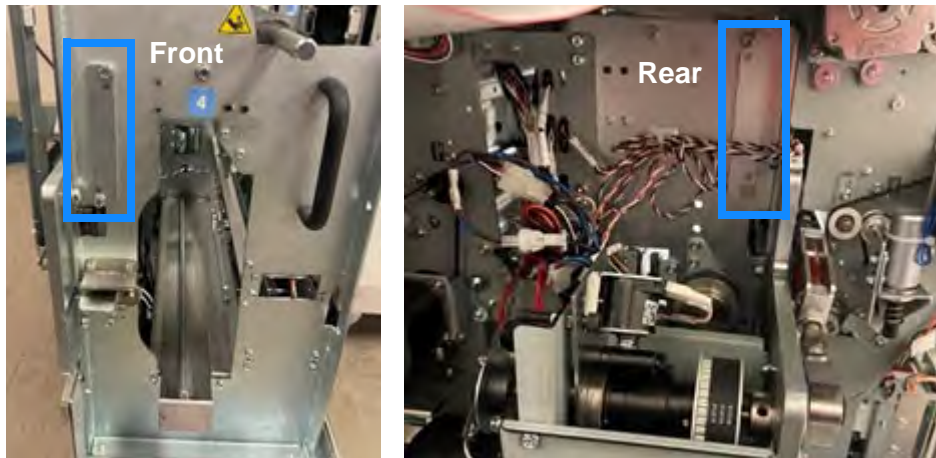

5. Remove the (2) 5.5mm screws holding the S24/receiver bracket, located on the toggle clamp baffle.



6. Place the S24/receiver bracket on exit baffle.



7. Grasp the toggle clamp bar and pull the locking mechanism up and out.

IMPORTANT: Keep it as straight as possible to avoid getting stuck on the frame walls.



Install

Install the new locking mechanism and follow the steps in reverse order and connect the power cord.

Handle

1. Open the front door and pull out the lamination drawer.
2. Use a 2.5mm Allen wrench to remove the (1) socket head cap screw.

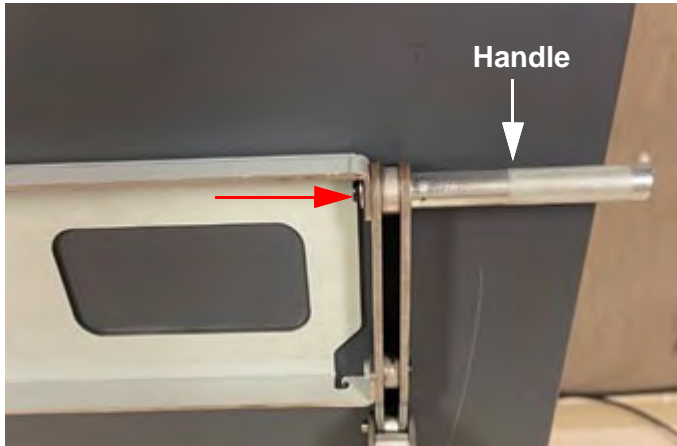

3. Install the new handle and tighten down the cap screw.
4. Push the lamination drawer in and close the front door.
5. Connect the power cord.

Clamps

1. Open the front door and pull out the lamination drawer.
2. Remove the [Locking Mechanism on page 195](#).
3. Remove the (2) 8mm screws.

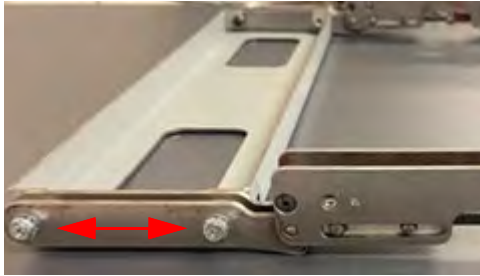

4. Remove the 2.5mm socket head cap screw.
5. Remove the handle, per the previous instructions.
6. Take the roller off of the clamps and either repair or replace the clamps by following the steps below.

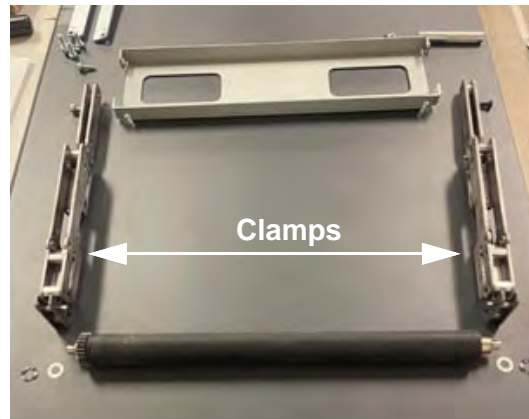

Follow the below instructions for each of the two toggle clamps.

7. Confirm that all of the flathead screws on the outside of each toggle are tight. It is especially important to check the four larger M4X8 screws (total of 8) and two smaller M3X5 (total of 4) on each face. Tighten these with an Allen wrench if required. See the diagram below.
8. Inspect the [Locking Mechanism Springs on page 237](#). If the springs are set incorrectly on either clamp, then adjust them following that procedure.
9. Inspect the top nut positions on the toggle clamp in the open position. See the picture below to check the meaning of "Top Nuts" and "Bottom Nuts". The top nuts should be tight with the rectangular washer at the top. If they have loosened, turn them with a 10mm wrench until they are snug against each other and the top washer.





10. Once the top nuts are tight, leave the toggle open. Measure the distance to the lower nuts using a pair of calipers and ensure it is 78mm. See the diagram to the right for where to measure. If the position is incorrect, adjust the bottom nuts using a 10mm wrench until the distance is correct. Make sure the two bottom nuts are snug with each other when finished.

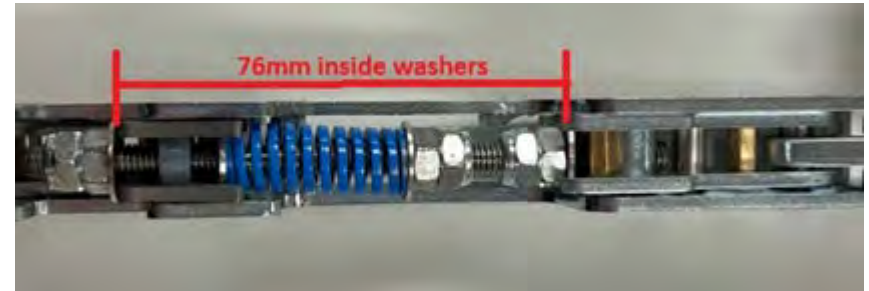

11. Close the toggle and check that the lower nuts have separated from the rest of the mechanism in this position. There should be an visible gap above the washer.



12. Repeat the steps in reverse order to re-install and connect the power cord.
13. Check if the locking mechanism is working as intended by running a short test job. If the mechanism is still not working, it will need to be replaced. Follow the previous repair steps, but instead of fixing the existing locking mechanism, replace it with new service parts.

Alignment Sensor Bracket

1. Open the front cover and pull out the lamination drawer.
2. Locate the alignment sensor bracket mounted on the aligner module.

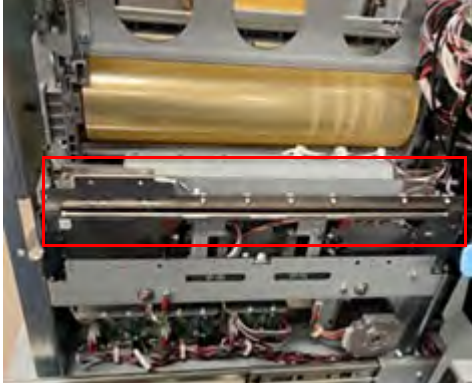

3. For easier removal push out (8) wire harness pins.

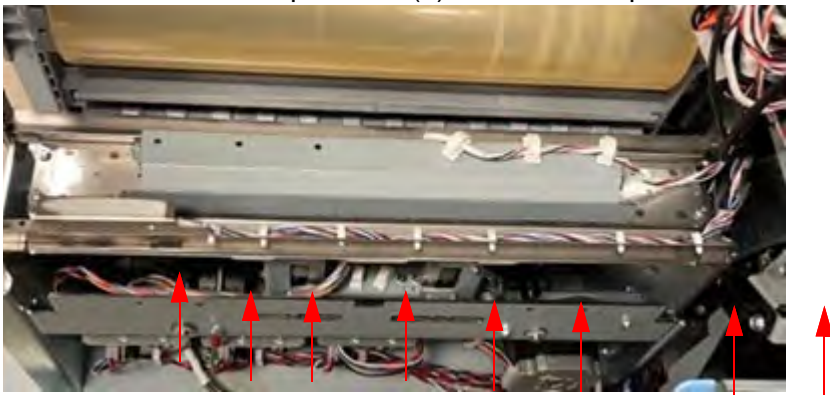

4. Loosen but do not remove the (2) 5.5mm nuts located below the alignment sensor bracket.

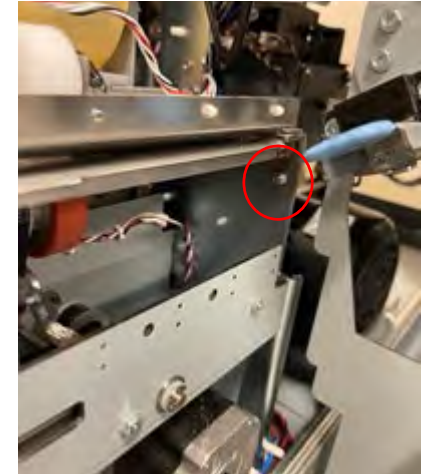

5. Carefully pull the bracket out until the alignment sensor connector is visible, then disconnect the alignment sensor board cable.

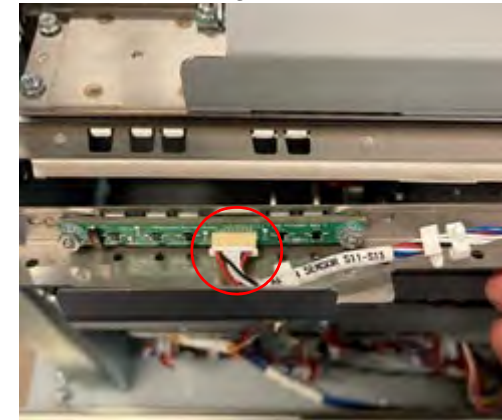

6. Perform procedure [Sensors 11 through 15 on page 156](#) to remove the board and install it onto the new alignment board bracket.
7. After the new bracket is installed ensure that both paper paths are at the same height and that the sheets will not be obstructed.

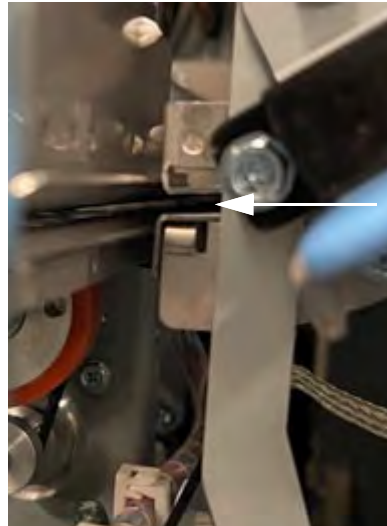

8. If the paper paths do not align, loosen the (2) 5.5mm nuts and adjust the bracket to the proper position, tightening the (2) nuts after.
9. Reconnect the power cord and run a single sheet to confirm that the alignment sensor bracket is not causing obstructions in the paper path.
10. If no jam occurs resume normal operation.

Electronics & Controls Repair Procedures

24V Power Supply

Remove

1. Remove the [Rear Cover on page 110](#).
2. Disconnect connectors J1 and J3 from the main control board.

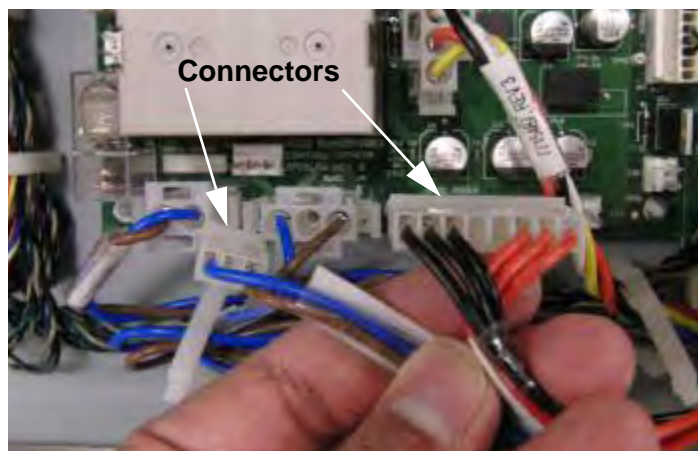

3. Remove the (1) M4 screw and remove the ground cable from the power supply.

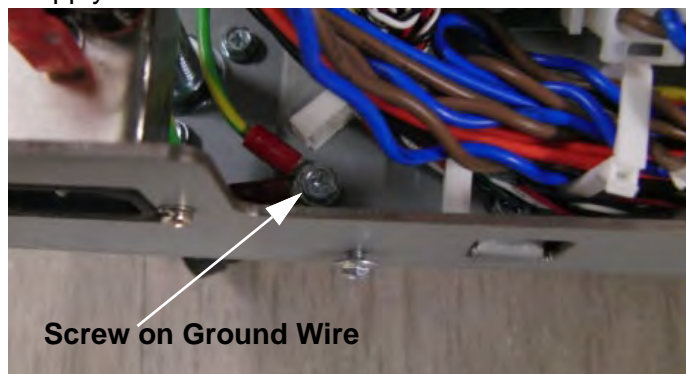

4. Remove the (4) M4 screws from the side of the base frame.



5. Remove the power supply and the cables through the opening on top by releasing the cable clamps and guiding the connectors through the grommet.

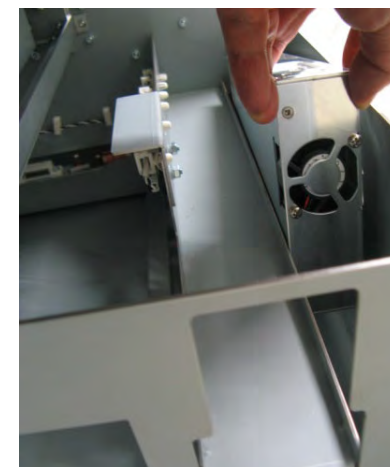

- Transfer all wires to the new Power Supply.



Install

- Tilt the power supply to insert it through the trim tray opening.
- Tighten the (4) M4 screws on the side of the base frame.
- Place the ground cable in position on the power supply and tighten the M4 screw.
- Connect connectors J1 and J3 to the main control board.
- Install the [Rear Cover on page 110](#).
- Connect the power cord.

AC Filter

- Remove the [Rear Cover on page 110](#).
- Remove the (2) Phillips screws and the AC filter-USB bracket mount.

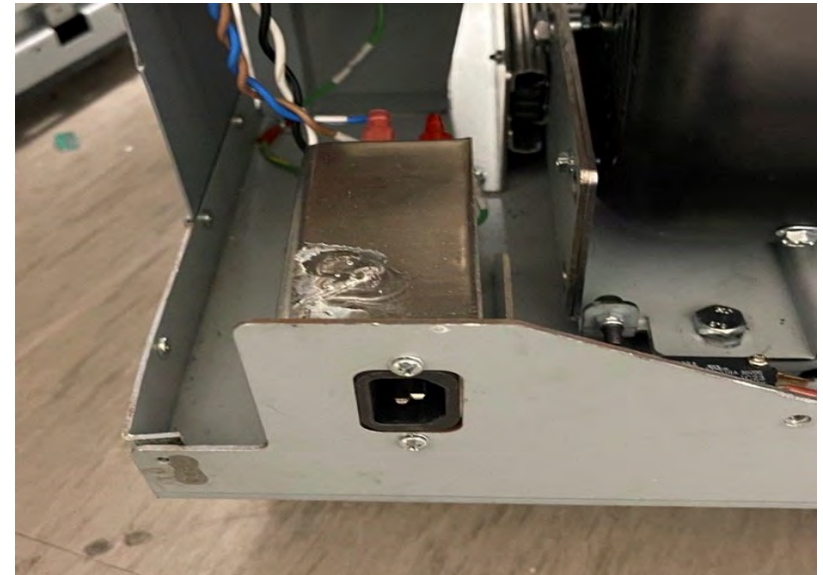

- Note the location of the (3) wires.
- Remove the (3) wires and the AC filter.
- Position the new AC filter and tighten the screws.
- Install the [Rear Cover on page 110](#).
- Connect the power cord.

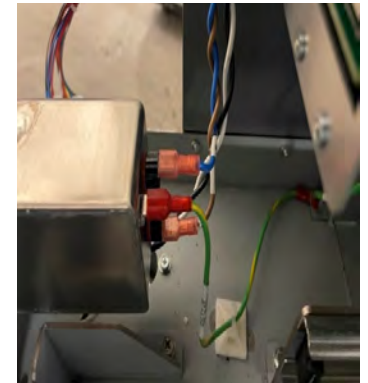

Main Control Board

IMPORTANT: Before replacing, get the number of lamination cycles.
See [Laminator Cycles on page 9](#).

Remove

1. Remove the [Rear Cover on page 110](#).
2. Remove the (4) M4 screws holding the PCB cover plate.
3. Remove the M3 screws from the main control and comm boards.

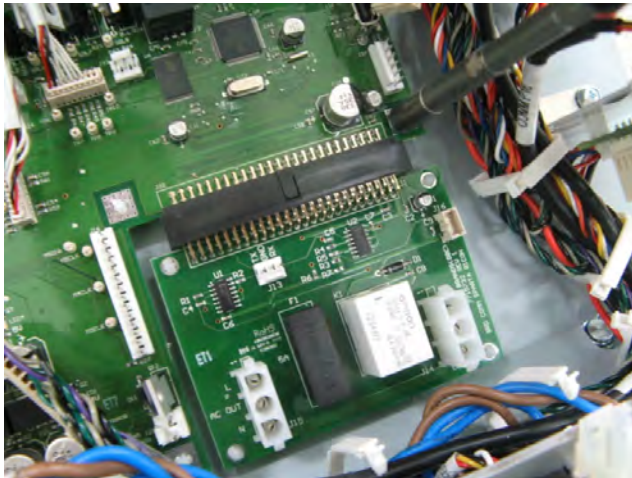

4. Disconnect the connectors from the main and comm boards and remove the boards.

5. Remove the plug-in connector from the comm to the main control board.



Install

1. Install the comm board on the main control board using the plug-in connector.
2. Place the new main control board and comm board in position.
3. Tighten the M3 screws to secure the boards.
4. Connect the connectors, using the previous positions as a guide.
Refer to [Wiring on page 263](#).
5. Replace the PCB cover plate using the (4) M4 Screws.
6. Install the Rear Cover.
7. Connect the power cord.

Communication Board

Remove

1. Remove the [Rear Cover on page 110](#).
2. Remove the (4) M4 screws holding the PCB cover plate.
3. Disconnect the (3) connectors.
4. Remove the M3 screw securing the comm board to the electrical panel.

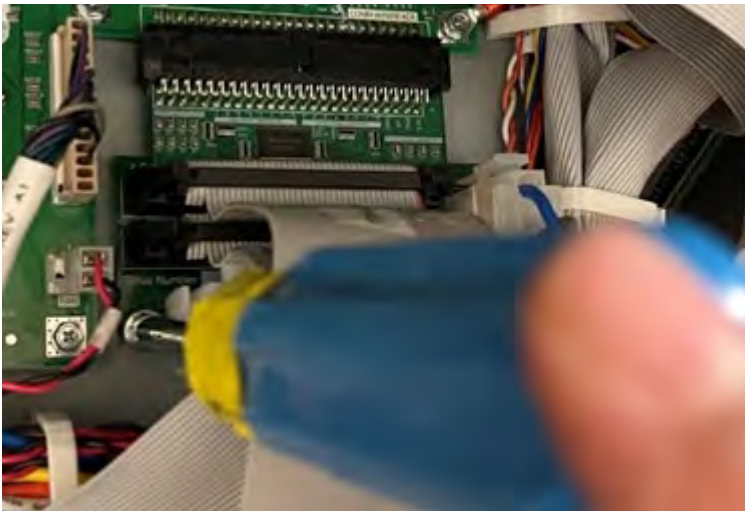

Install

1. Place the new comm board in position by inserting the plug-in connector to the main board and pressing on (4) standoffs until it snaps in place.
2. Connect the (3) connectors.
3. Replace the PCB cover plate using the M4 screws.
4. Install the [Rear Cover on page 110](#).
5. Connect the power cord.

Chip Reader

Remove

1. Remove film cartridge.
2. Remove the [Rear Cover on page 110](#).
3. Locate the chip reader and disconnect the cable (may have to undo the first wire saddles).
4. Open the front door and remove the (2) M3 screws holding the reader.

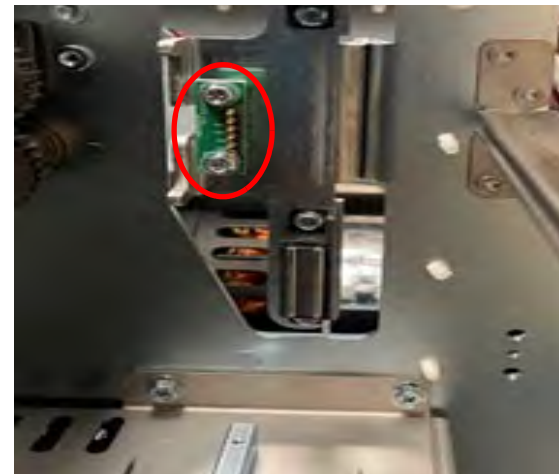

Install

1. Place the new chip reader in position and secure with (2) M3 screws.
2. At the rear, seat the cable connection and saddle.
3. Insert film cartridge so that contact is made between the film chip board and the chip reader.
4. Install the [Rear Cover on page 110](#).
5. Connect the power cord.

Bracket

Remove

1. Remove film cartridge.
2. Remove the [Rear Cover on page 110](#).
3. Locate the chip reader and disconnect the cable.
4. Remove the (2) 7mm screws holding the bracket.

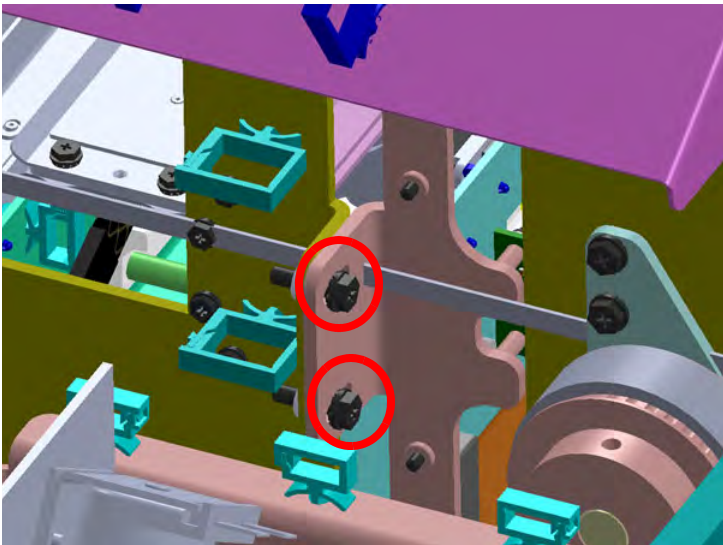

Install

1. Place the new bracket in position and secure with (2) screws.
2. Connect the cable.
3. Perform the adjustment for the [Cartridge Stop Magnet on page 212](#).
4. Install the [Rear Cover on page 110](#).
5. Connect the power cord.

Breakout Board

1. Remove the [Rear Cover on page 110](#).
2. Locate the upper fan mount panel and remove the (1) 7mm screw.

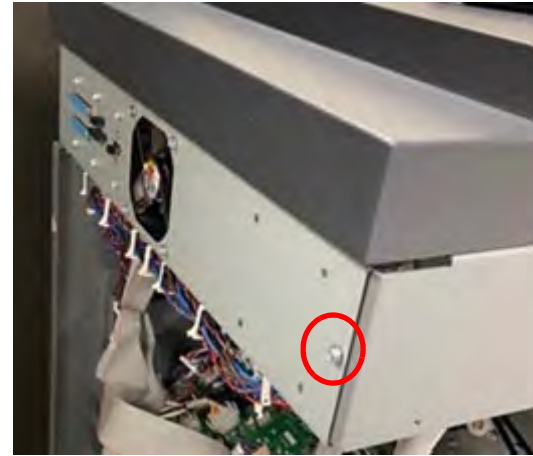

3. Open the panel outward.



4. Disconnect the (5) connectors on the breakout board and remove the (4) 5.5mm screws.

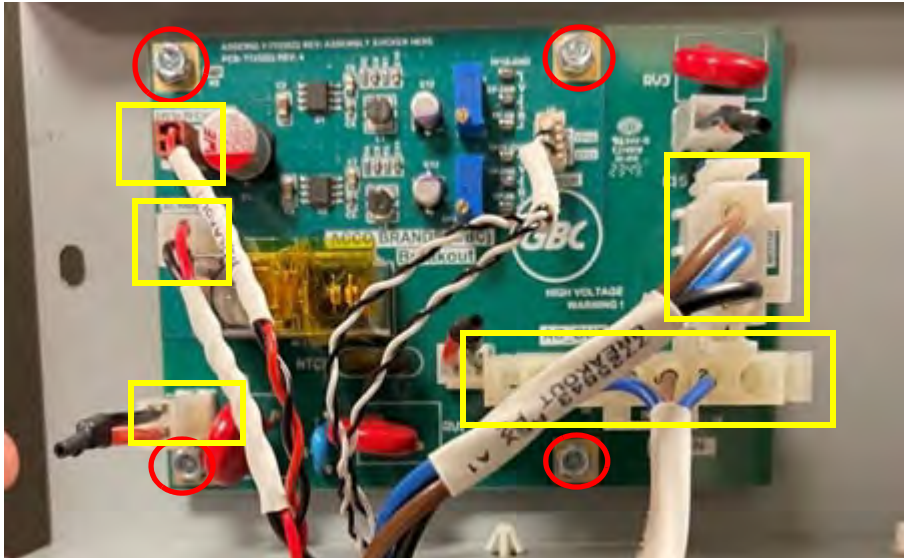

8. Use procedures [S1B - Cutter on page 239](#) and [Sensor S29 Trim Tray on page 100](#) to check the resistance and voltages.
9. Replace the (1) 7mm screw to secure the fan bracket.
10. Install the [Rear Cover on page 110](#).

5. Replace the board.

The Breakout Board replacement should have 3 jumpers.



6. Secure the board using the (4) 5.5mm screws.

7. Reconnect the (5) cables.

Adjustments

Click on the [blue](#) links, shown below, to be taken to the relevant adjustment procedure.

Precautions	208
Pre-Requisites	208
Rear Cover	208
Tools Needed	208
Door Latch	209
Solenoids	210
Diverter Solenoid (SOL1)	210
Trim Diverter Solenoid (SOL 8)	211
Cartridge	212
Stop Magnet	212
Cartridge Foot	213
Stop Bracket	213
Rail Height	215
Paper Path	216
Magnets	216
Pressure Roller Idler	217
Timing Belts	218
Steering Sub-Assembly	218
539T Timing Belt	218
166T Timing Belt	219
132T Timing Belt	220
197T Timing Belt	221
162T Timing Belt	221
Steering Motor Belt	222
Idler Panel Magnetic Latches	223
Drive Panel	224
Entrance Drive Panel	224
Exit Drive Panel	225
Lower Bypass Panel	227
Cutter Module	228
Motor Belt Tension	228
Clutch Indexing	229
Pivot	230
Connecting Rod Length	231
Connecting Rod Spring	233
Lamination Drawer	235
Alignment Pin	235
Drawer Switch	236
Cut Stick	236
Locking Mechanism Springs	237
Drawer Latch	238
Sensors	239
S1B - Cutter	239

Precautions



WARNING: Before executing any adjustments turn power off and unplug power cord.



DANGER: HIGH VOLTAGE

Pre-Requisites

In many cases it will be necessary to remove other parts to get to the area for adjustment.

Rear Cover

Removal

1. Disconnect the communication cables from the rear side of the machine and remove the MK 737 boxes.
2. Hold the rear cover in place while removing the (6) M4 X 8 screws from the rear cover.
3. Grasp the handle and remove the rear cover.

Installation

1. Place the rear cover in position and tighten the (6) screws.
2. Install the MK 737 boxes.
3. Connect the Communication cables.
4. Connect the power cord.

Tools Needed

Recommended tools for making adjustments.

Standard Tools (metric)

- Phillips Screwdriver
- Ruler
- 5.5mm Allen Wrench
- 5.5mm Hex Wrench
- 8mm Hex Wrench
- 7mm Hex Driver
- 9mm Crescent Wrench
- 13mm Crescent Wrench
- 14mm Crescent Wrench
- 15mm Combination Wrench
- 17mm Combination Wrench

Other Recommended Tools and Supplies

- 0.25mm, 0.50mm Shim Gauges

Door Latch

Do the following to ensure the door latch holds the door closed and that the activating bracket tab depresses the door switch. The tab should press the switch button just so that it is close to bottoming out.

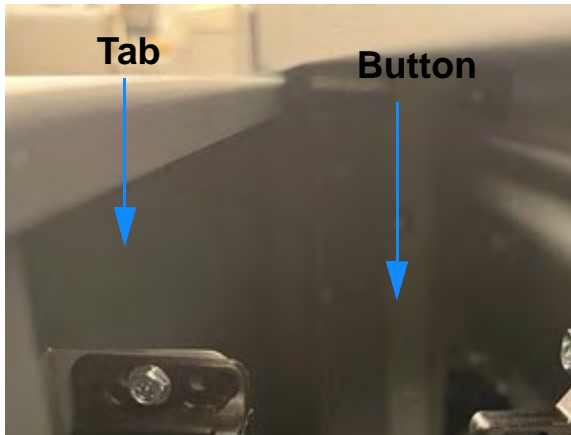

1. Open the Front Door.
2. Loosen the (2) adjustment screws on the door latch.
3. Do one of the following:
 - Move the door **in** by moving the latch towards the front of the door.
 - Move the door **out** by moving the latch away from the front of the door.
4. Tighten the Adjustment Screws (2).
5. Close the Front Door.
6. Connect the Power Cord.
7. Test the Door Latch operation.

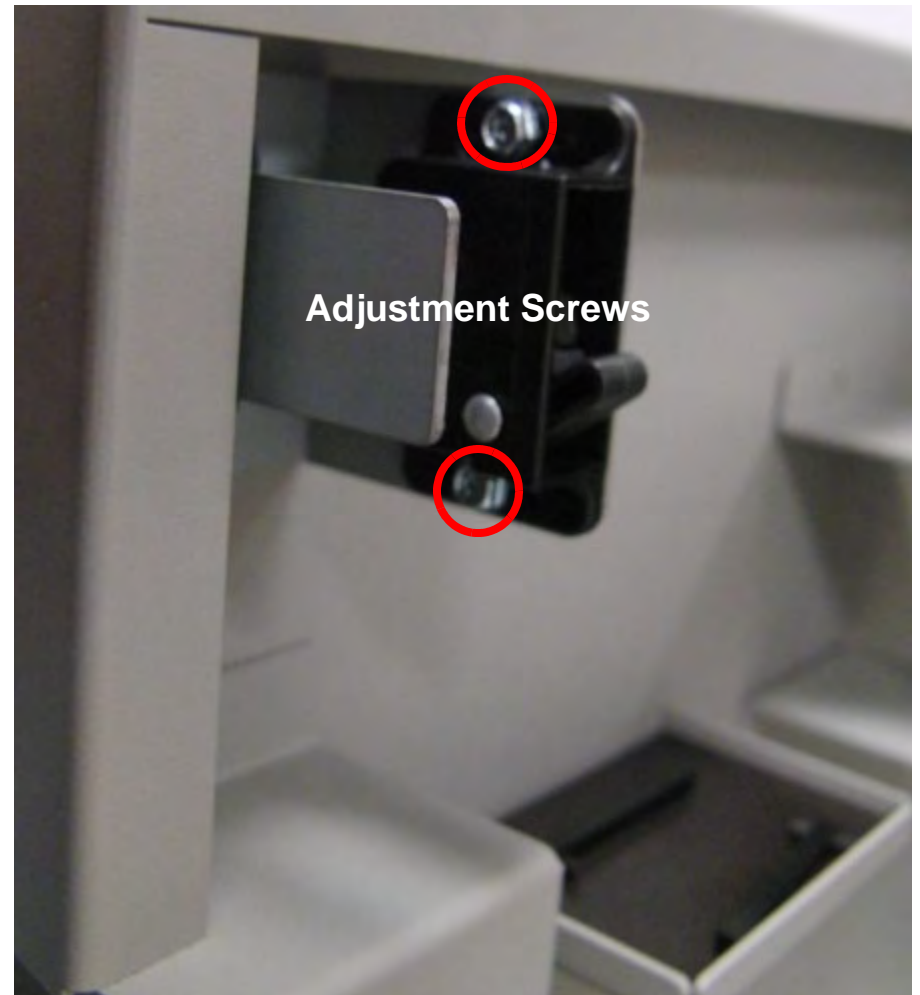

Solenoids

Diverter Solenoid (SOL1)



DANGER: HIGH VOLTAGE

1. Open the front door.
2. Remove the [Rear Cover on page 208](#).
3. Insert the interlock cheater.
4. Follow instructions in [Solenoids on page 12](#) to activate SOL1.
This will switch the diverter gate to lamination mode allowing the diverter gate to rise and hit the upper bypass panel.



When the solenoid is not actuated, it needs to rest on the diverter limiter bracket.

5. Adjust the position of the limiter bracket, by loosening the (2) screws on the bracket.
6. Insert a 0.25 to 0.5mm shim between the diverter and the lower entrance panel.

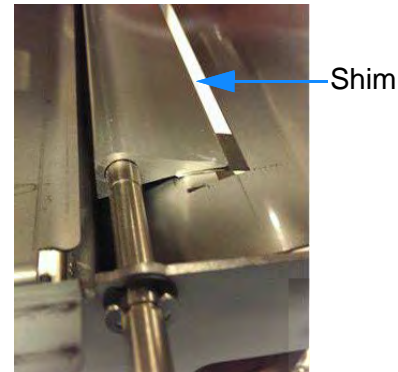

7. Raise the limiter bracket so that it just touches the diverter link and tighten the (2) screws.

NOTE: Raising the limiter bracket too high will position the diverter gate higher, which will obstruct the paper flow and cause jams.

8. Check that the clearance between the diverter and the cutout in the lower entrance panel at both sides has a minimum clearance of 1.0mm.
9. Install the [Rear Cover on page 208](#).

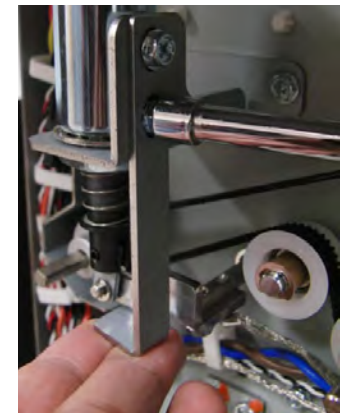
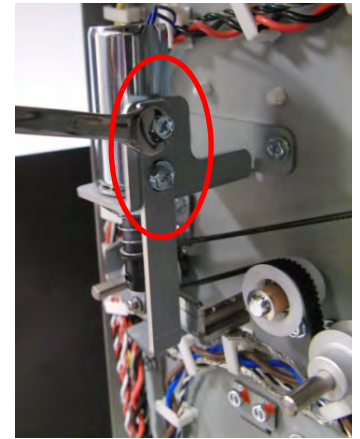

Trim Diverter Solenoid (SOL 8)

If the trim diverter solenoid is not set correctly, jams will occur in the area immediately after the knife. The trim diverter must be set so that when it activates and switches to the laminate path position, it is open wide enough to accept sheets, but not so wide as to touch the trim drive rollers.

If trim pieces were not purging correctly, start with step 1.

If M9 was stalling, skip to step 2.

1. Open the front door and check that the diverter is sitting within the position of the brown diverter shown in the drawing below.

The top should be touching the upper paper path panel and there should be no contact with the rollers.

- To check for roller to diverter contact, slide a piece of paper between the roller and diverter. Hold the roller with one hand, to prevent it from spinning, and remove the paper with the other. There should only be light resistance to the paper coming free.
- If the paper is tight, or forces the roller to turn, follow the procedure to clean the [Trim Diverter on page 38](#).

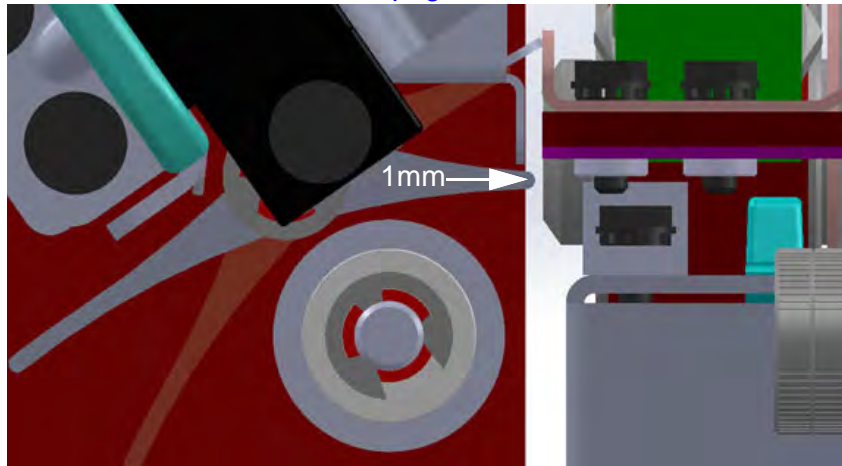

2. Plug in the power cord, power up the machine and follow the instructions for [Solenoids on page 12](#) to power on SOL8.

The diverter should be in the gray position as shown in the aforementioned drawing. The tip of the diverter should be 1-2mm below the plane of the lower panel of the cutter outfeed.

3. Power off the machine and unplug the power cord.
 4. Remove the [Rear Cover on page 208](#).
 5. Loosen the (2) 7mm screws holding the solenoid limiting bracket.
- IMPORTANT:** Do NOT remove the screws.
6. If the diverter is sitting too high, raise the limiter slightly (<1mm) and if sitting too low, lower it slightly (<1mm) and tighten the screws.

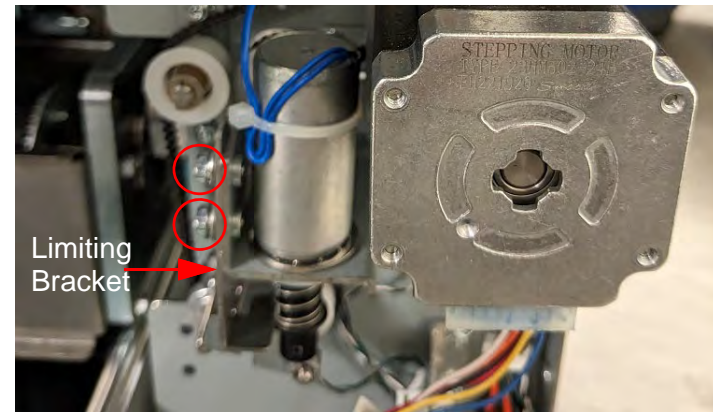

7. Repeat the steps until the diverter is in the correct position.
 8. Run the procedure [Solenoids on page 12](#) to power on SOL8 and the [Motors on page 11](#) to confirm that M9 is not stalling.
- If M9 is stalling repeat the steps to adjust the limiting bracket. If M9 will not operate correctly with the diverter in the correct position, check the tension on [197T Timing Belt on page 221](#).
9. Install the [Rear Cover on page 208](#).
 10. Connect the power cord.

Cartridge

Stop Magnet

1. Remove the film cartridge.
2. Locate the cartridge magnet bracket.



3. Remove the back cover
4. From the rear of the machine, locate the cartridge magnet bracket
5. Loosen, but do NOT remove, the (2) screws on the bracket.



6. Reinsert the film cartridge.
7. Using the cartridge foot as a stopper, ensure that the cartridge sits flush against the foot.



8. Go to the rear of the machine and adjust the cartridge magnet bracket forward or backward, as needed, ensuring it makes contact with the cartridge magnet and that the cartridge is sitting flush against the foot.
9. Tighten the (2) screws on the bracket.
10. Connect the power cord and resume normal operation.

Cartridge Foot

1. Open the front door and pull out the laminator drawer.
2. Remove the film cartridge.
3. Locate the Cartridge foot.



4. Loosen, but do NOT remove, the (2) screws on the cartridge foot.
5. Move the cartridge foot forward or backward, as needed, to achieve the correct alignment position.
6. Tighten the two screws securely.
7. Perform the adjustment for [Stop Magnet on page 212](#).
8. Insert the film cartridge and run one laminated sheet to confirm the alignment adjustment is correct.

NOTE: The sheet should be centered in the film when the LCD margin adjustment is set to within 0 +/-0.5mm. The LCD margin adjustment is not meant to make up for gross film misalignment.

9. Connect the power cord and resume normal operation.

Stop Bracket

This procedure is necessary after a cartridge magnet adjustment.

1. Open the front door and pull out the laminator drawer.
2. Remove the cartridge frame, if present, in the slot.
3. Raise the handle on the pressure roller lock to the open position.
4. Locate and loosen the (2) bolts, holding the cartridge lock in place on the clamp crossmember, until the locks can move freely in their respective slots.

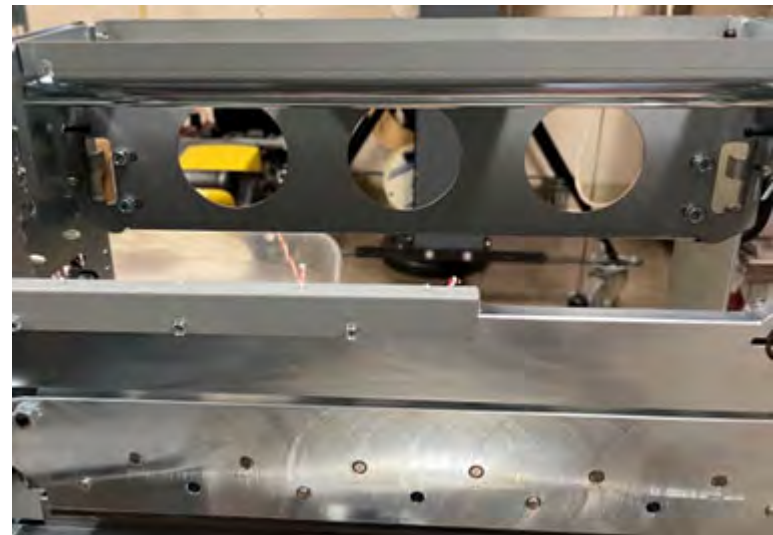

5. Insert the cartridge back into the drawer.
6. Move the handle to the locked position on the pressure roller lock.
7. Inspect where the cartridge locks are contacting the frame tabs. They should be just in front of the tabs and preventing the cartridge from shifting forwards.
8. Adjust the tabs to the proper position as shown in the next pictures.



9. Tighten the (4) bolts back in place to fix the cartridge locks into their new position.
10. Push the drawer into the machine.
11. Connect the power cord and power on the machine.

Rail Height

1. Open the front door and pull out the laminator drawer. Loosen the (4) screws located on the cartridge tray.

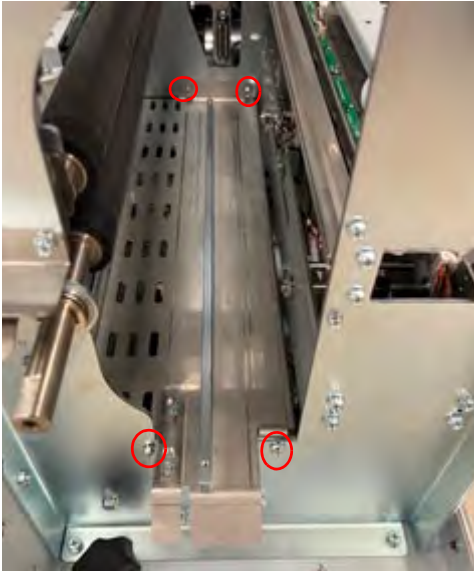

2. To lower the cartridge tray, lightly tap on the front and rear of the tray.
3. To raise the tray, insert an Allen key in the gap between the tray & aligner module.



4. Carefully rotate the Allen key while it is inserted between the tray and aligner module.

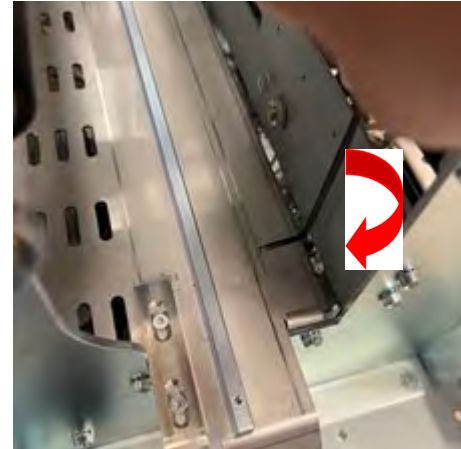

5. Pull up on the tray using the Allen key.

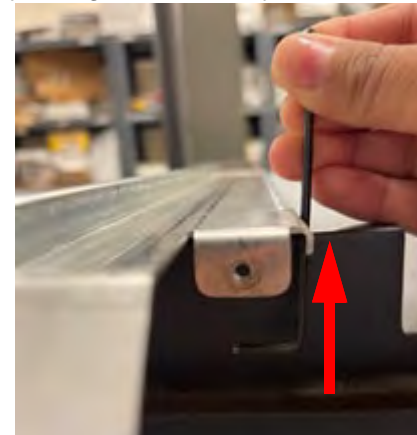

6. Repeat this process on all four sides of the cartridge tray.
7. Tighten the (4) screws on the cartridge tray after making the proper adjustments.
8. Insert the film cartridge and ensure the film size and count are being read properly on the screen.
9. Connect the power cord and resume normal operation.

Paper Path

Magnets

When the paper path panels are latched there should not be any movement or gaps in the panels. If there is, adjust the magnet by doing the following:

1. Open the front door.
2. Locate the magnets shown in the picture below.

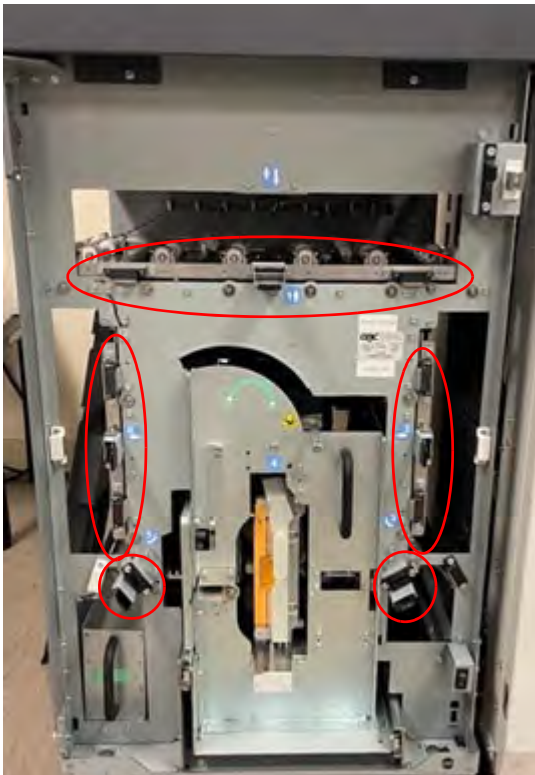

3. Loosen the (2) screws that hold the magnet.
The screws should be tightened while the panel is fully closed.

4. Push the panel in or up to eliminate any movement/gaps.

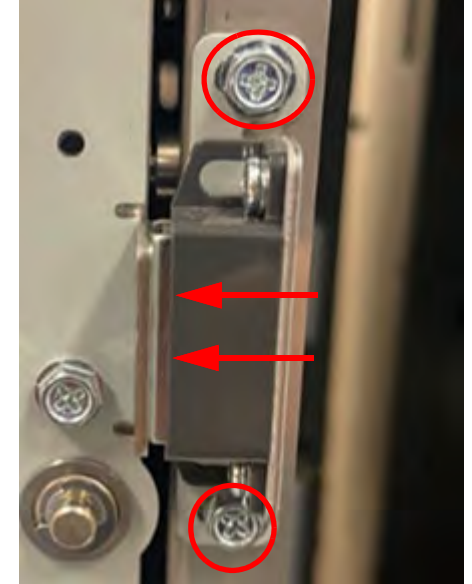

5. If dog ear issues occur on sheets, ensure the right curved panel in area 3 is properly adjusted.

- To further adjust the right curved panel, locate the magnet found towards the rear of the panel.



- Loosen the nut on the magnet plate and push the panel inward ensuring contact between the two.



- Run a test job to ensure dog eared sheets are gone.
- Connect the power cord and resume normal operation.

Pressure Roller Idler

- Remove the [Rear Cover on page 208](#).
- Locate the idler roller, found near M8.
- Loosen the (2) nuts on the idler bracket.

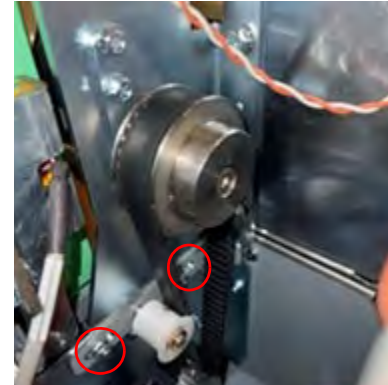

- Tighten the bolt, located on the frame of the laminator, by tightening the (2) nuts on the bracket.



- Ensure the belt is tight.
- Connect the power cord and resume normal operation.

Timing Belts

Steering Sub-Assembly



DANGER: HIGH VOLTAGE

1. Open the front door.
2. Pull out the laminator drawer.
3. Remove the (4) screws in the cartridge rail.

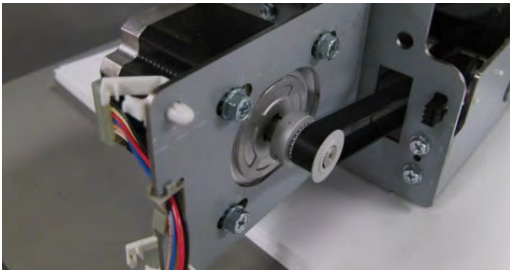

4. Adjust the belt tension such that there is a deflection of 1~2mm.

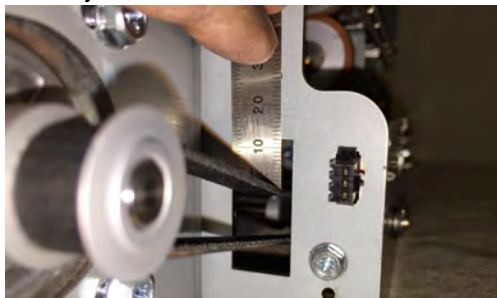

5. Tighten the (4) Phillips screws.
6. Install the cartridge rail.
7. Push in the drawer and close the door.
8. Connect the power cord.

539T Timing Belt

Use this procedure to adjust the tension of 539T timing belt.



DANGER: HIGH VOLTAGE

1. Remove the [Rear Cover on page 208](#).
2. Loosen the tensioner.
3. Adjust the belt tension such that there is a deflection of 6~8mm.



4. Tighten the tensioner.
5. Install the [Rear Cover on page 208](#).
6. Connect the power cord.

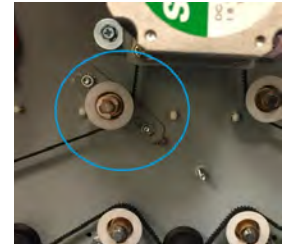

166T Timing Belt

Use this procedure to adjust the tension of 166T timing belt.



DANGER: HIGH VOLTAGE

1. Remove the [Rear Cover on page 208](#).
2. Loosen the tensioner.

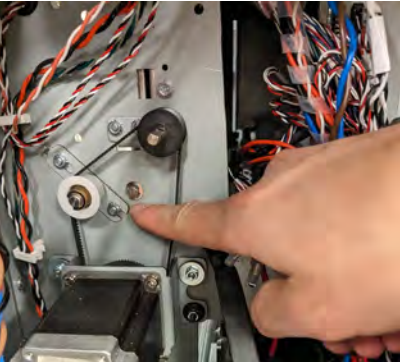

3. Adjust the belt tension such that there is a deflection of 3~5mm.

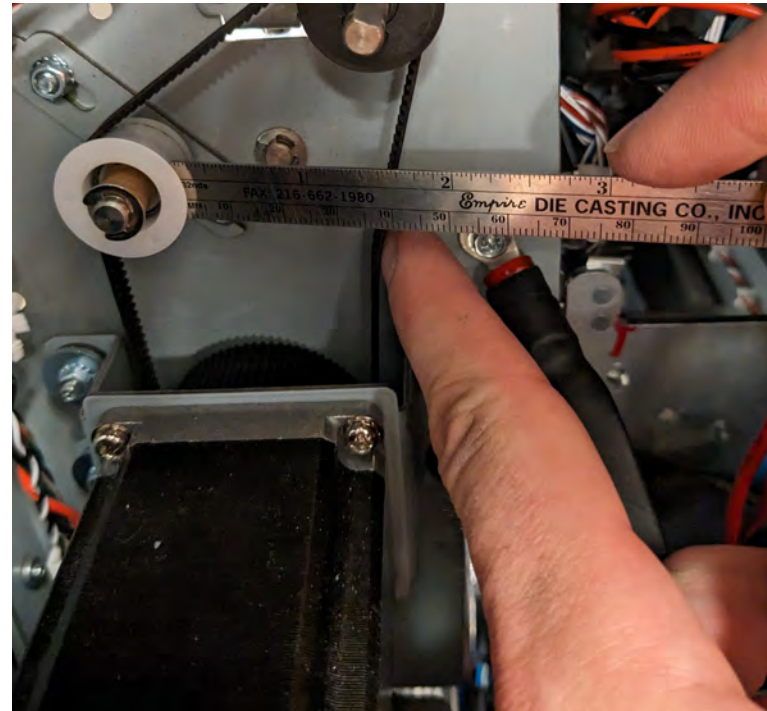

4. Tighten the tensioner.
5. Install the [Rear Cover on page 208](#).
6. Connect the power cord.

132T Timing Belt

Use this procedure to adjust the tension of 132T timing belt.



DANGER: HIGH VOLTAGE

1. Remove the [Rear Cover on page 208](#).
2. Loosen the tensioner.

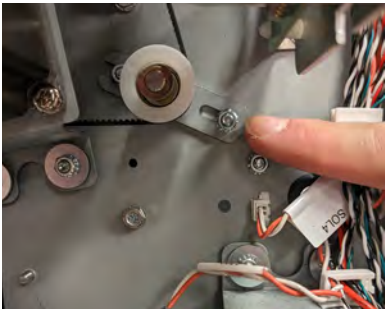

3. Adjust the belt tension such that there is a deflection of 4~6mm.

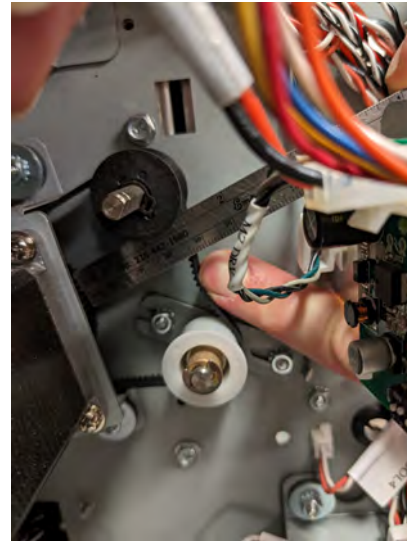
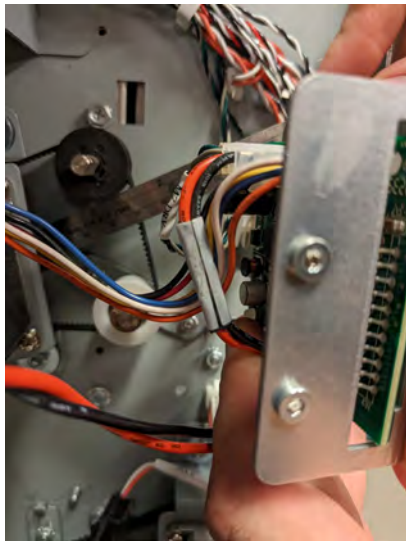

4. Tighten the tensioner.
5. Install the [Rear Cover on page 208](#).
6. Connect the power cord.

197T Timing Belt

Use this procedure to adjust the tension of 197T timing belt.

NOTE: If this belt is too loose, it can result in the belt skipping when running thicker paper. If the belt is too tight, it can result in the motor stalling.



DANGER: HIGH VOLTAGE

1. Remove the [Rear Cover on page 208](#).
2. Loosen the tensioner.

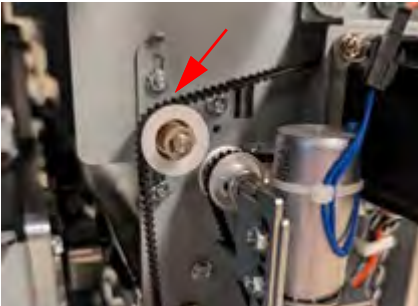

3. Adjust the belt tension such that there is a deflection of 3~5mm.



4. Tighten the tensioner.
5. Install the [Rear Cover on page 208](#).
6. Connect the power cord.

162T Timing Belt

Use this procedure to adjust the tension of 162T timing belt.



DANGER: HIGH VOLTAGE

1. Remove the [Rear Cover on page 208](#).
2. Loosen the tensioner.



3. Adjust the belt tension such that there is a deflection of 4~6mm.



4. Tighten the tensioner.
5. Install the [Rear Cover on page 208](#).
6. Connect the power cord.

Steering Motor Belt

Use this procedure to adjust the tension of the steering motor belt.



DANGER: HIGH VOLTAGE

1. Open the front door.
2. Pull out the drawer.
3. Loosen the (4) Phillips screws from the steering stepper motor.
Move the steering carriage to access all screws

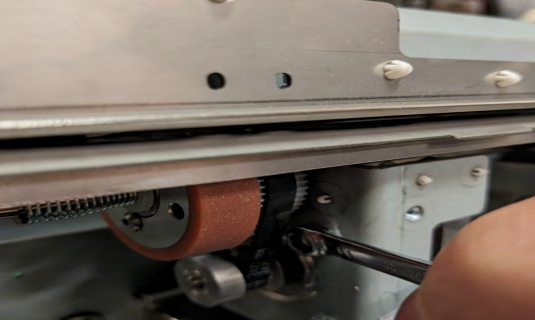

4. Adjust the belt tension such that there is a deflection of 1~2mm.

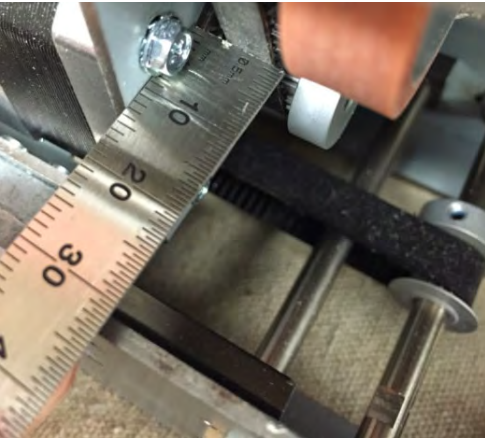

5. Tighten the (4) Phillips screws.
6. Push in the drawer.
7. Close the front door.
8. Connect the power cord.

Idler Panel Magnetic Latches

This procedure applies to:

- Entrance Idler Panel
- Exit Idler Panel
- Upper Bypass Panel

Two round spacer studs should contact the drive panels completely. If there is movement when the idler assembly is latched, adjust the assembly.

This procedure applies to:

- Lower Exit Panel Assembly
- Acceleration Panel

Loosen the (2) screws that hold the magnet.

With the panel fully closed (the panel will hit limiting tabs and you will hear a sound), tighten the two screws.

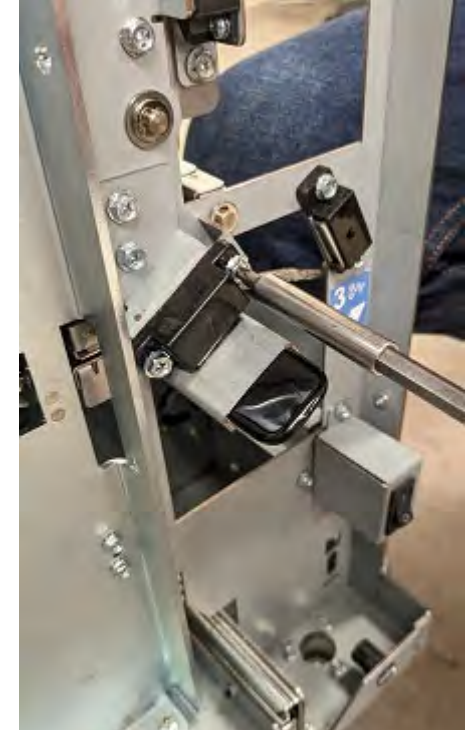
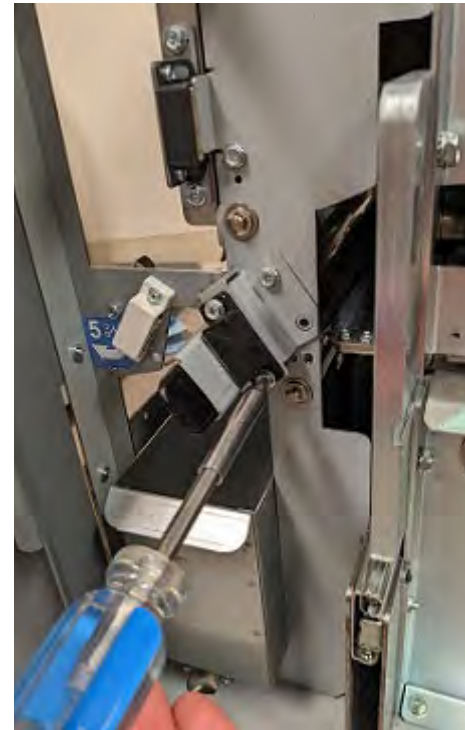

Drive Panel

Use this procedure to adjust the drive panel positions.

The drive panels control how far the drive rollers protrude into the paper path, which in turn control the roller nip forces. All drive rollers should be protruding $1.5\pm 0.5\text{mm}$ through the paper path.

This drive panel controls the nip forces of N2, N3, N4 and N5.

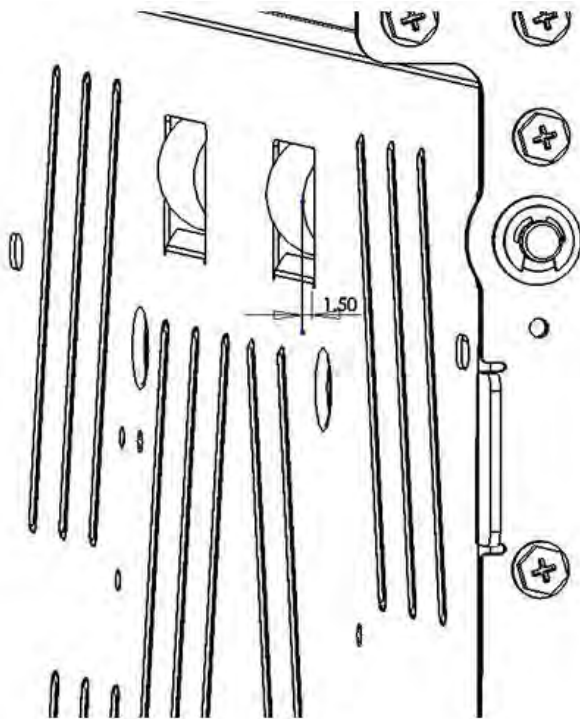

To adjust the position of the drive panel, loosen (5) screws from the front frame and (5) screws from the rear frame.

- Entrance Drive Panel
- Exit Drive Panel
- Lower Bypass Panel

Entrance Drive Panel

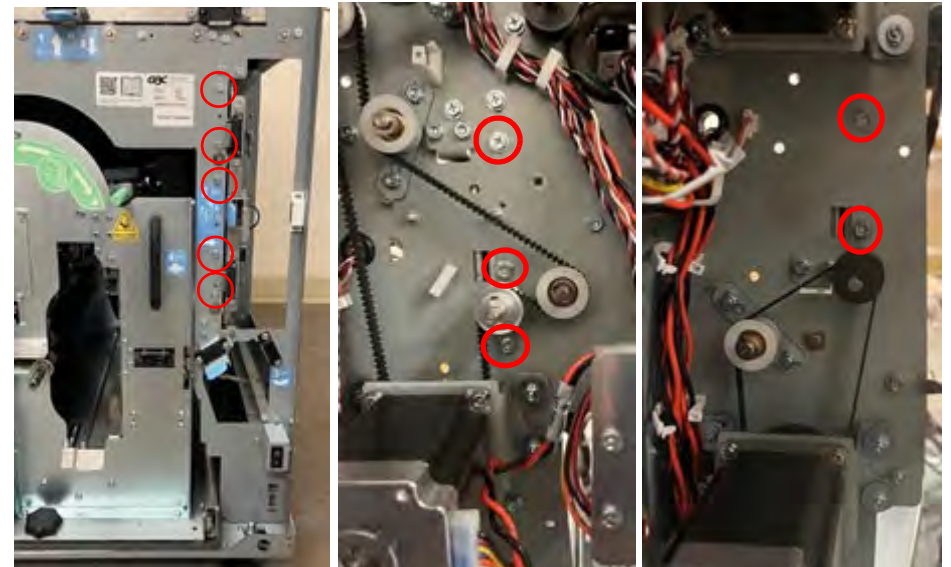

Using the (5) reference holes, each, in the front and rear frames and the sheet metal panel, position the drive panel to ensure the drive rollers protrude $1.5 \pm 0.5\text{mm}$ through the drive panel.

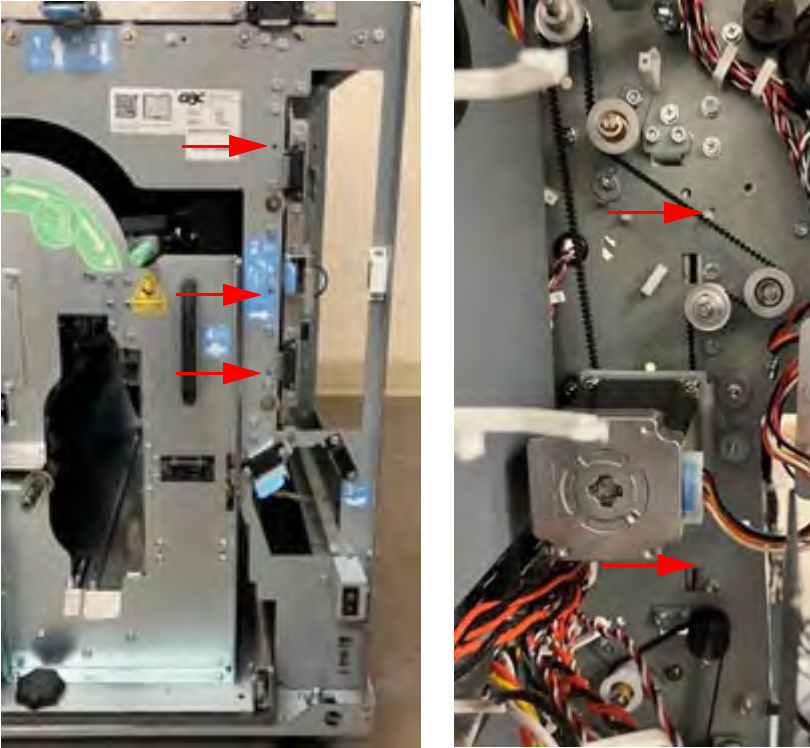

Exit Drive Panel

This drive panel controls the nip forces of N8, N9 and N10.

1. To adjust the position of the drive panel, loosen (6) screws from the front frame and (6) screws from the rear frame.

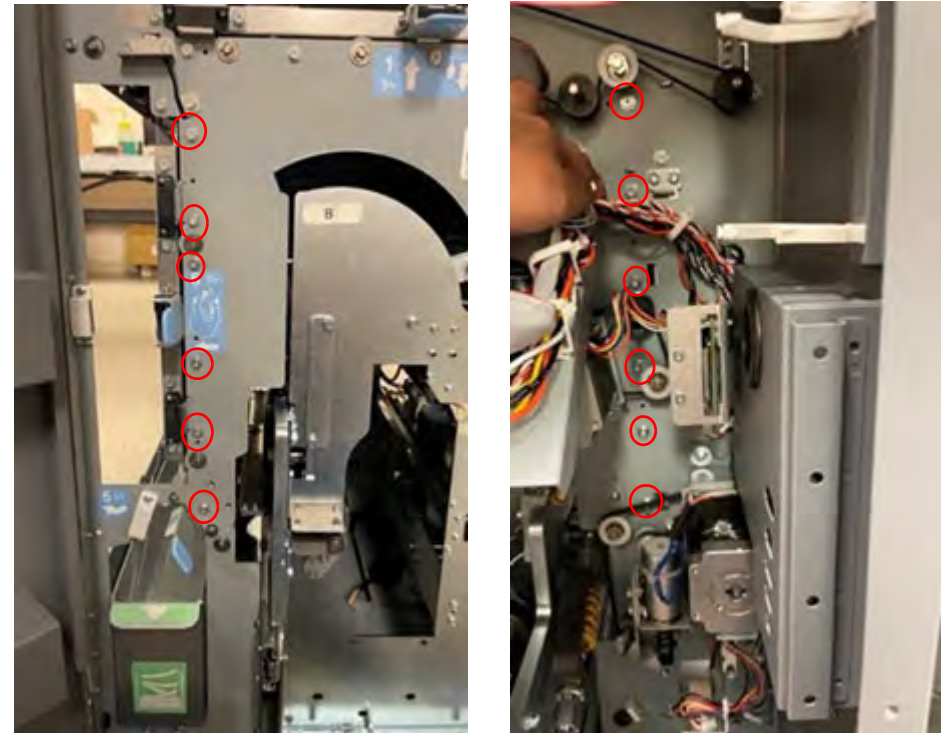

2. Remove the cover plate from Jam area 5.

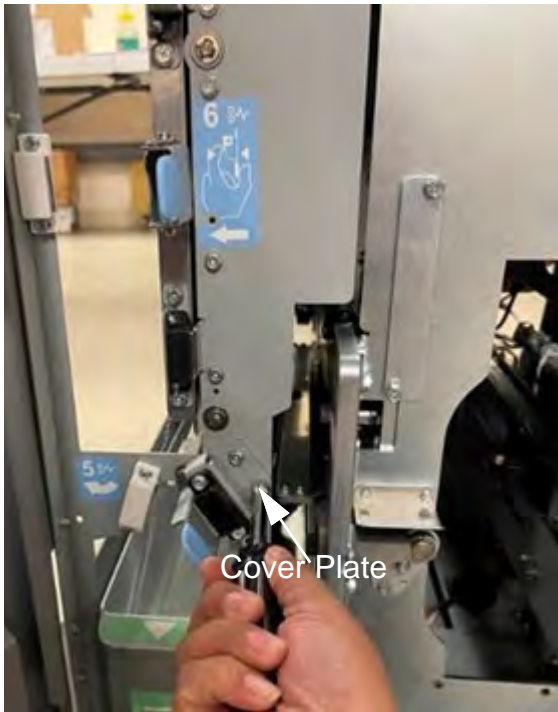

3. Use the (6) reference holes in the front and (5) in the rear frames and the sheet metal panel, position the drive panel to ensure the drive rollers protrude 1.5 ± 0.5 mm through the drive panel.

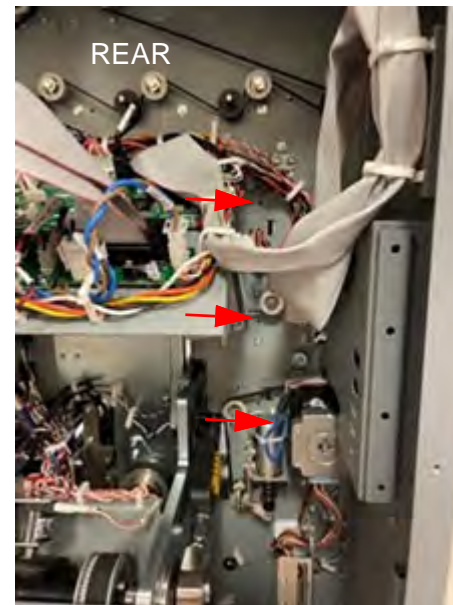
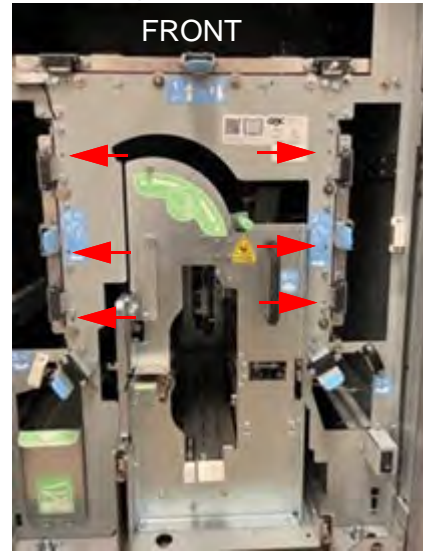

Lower Bypass Panel

This drive panel controls the nip forces of N12, N13 and N14.

To adjust the position of the lower bypass panel, loosen (5) screws from the Front frame and (5) screws from the rear frame.



Use the reference holes in the front (2) and rear (3) frames and the sheet metal panel, position the drive panel to ensure the drive rollers protrude 1.5 ± 0.5 mm through the drive panel

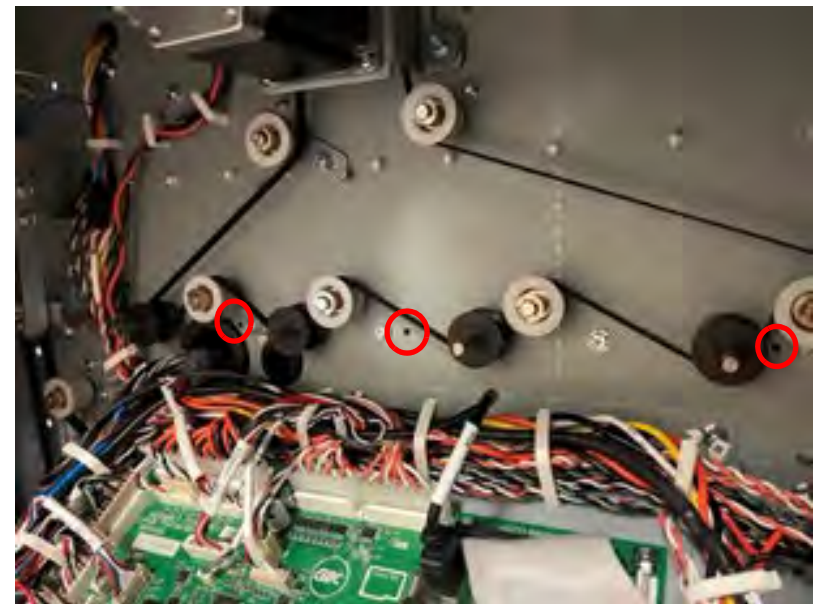
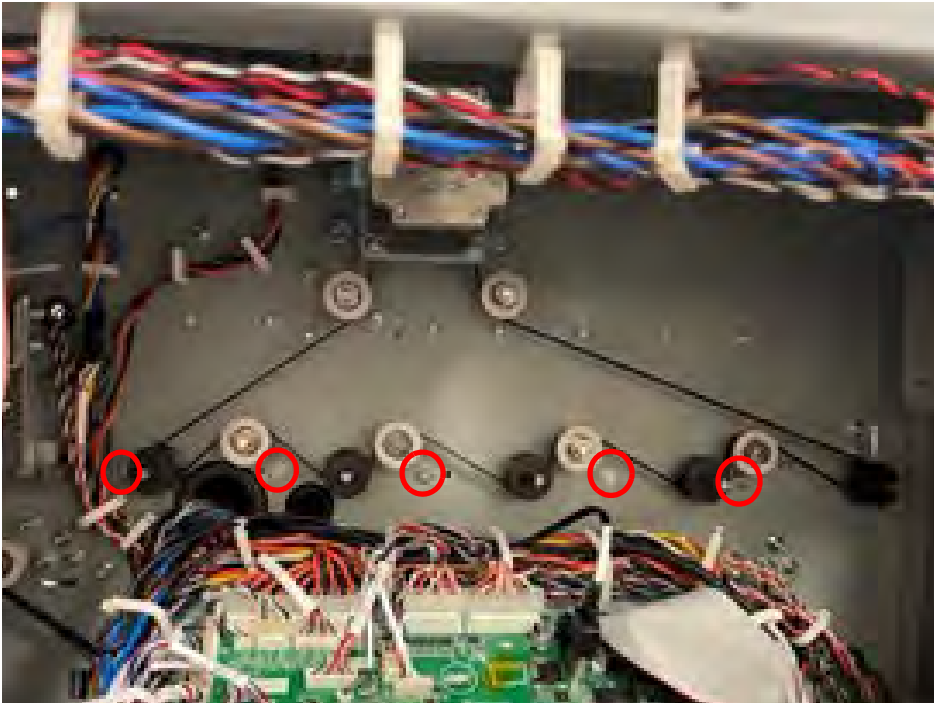
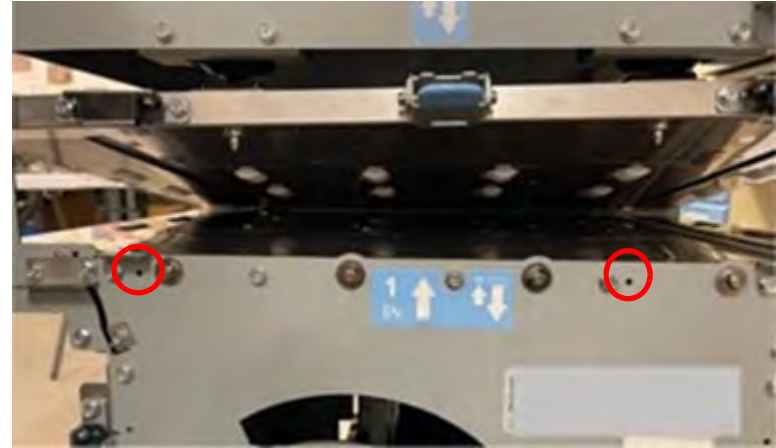

Cutter Module

Motor Belt Tension

1. Remove the [Rear Cover on page 208](#).
2. Loosen the (5) bolts using a 13mm wrench.

IMPORTANT: Do not remove the bolts and do not loosen the bolts marked with red in the drawing below.

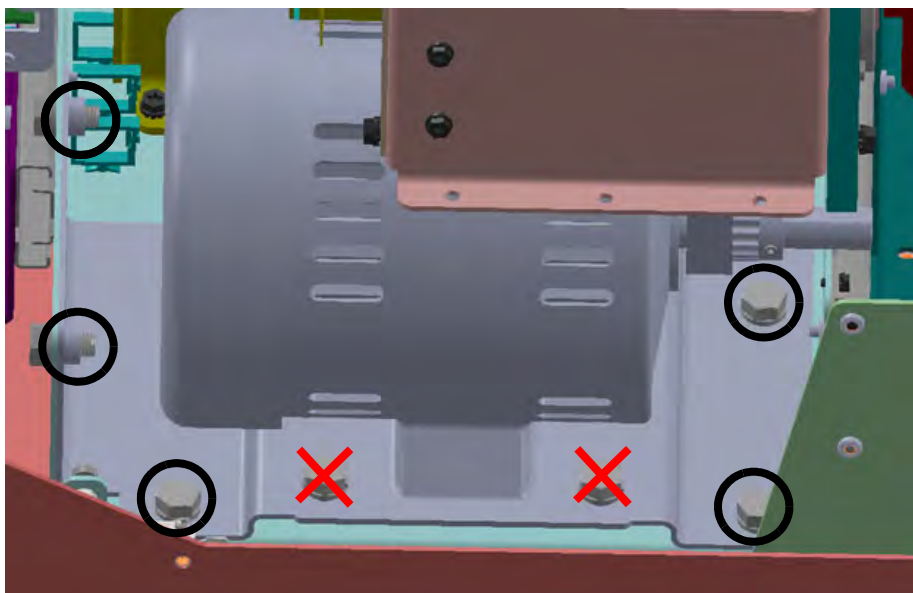

3. Slide the motor and mounting plate to achieve approximately 5mm of deflection at the center of the belt.

NOTE: Belt tension can be difficult to measure accurately. Loose belts can result in cutter jams. If those occur, the belt can be tightened beyond what seems to be 5mm of deflection.

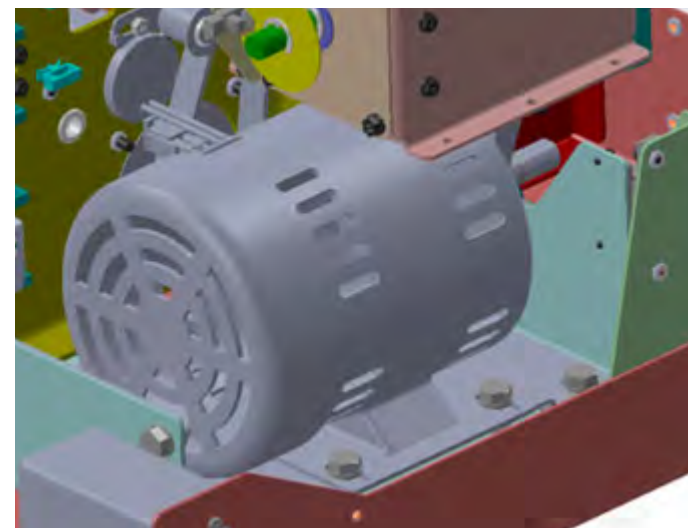

4. Tighten the bolts, starting with the two on the vertical surface.
5. Install the [Rear Cover on page 208](#).
6. Connect the power cord.
7. Use the service commands (see [Motors on page 11](#)) to cycle the cutter to ensure that the motor spins freely without jamming.

Clutch Indexing

Use this procedure to correct the crank home position. The cutter home position must be set correctly to prevent the motor from stalling and sheets getting stuck in the cutter area.

1. Verify that the cutter clutch needs to be indexed.

IMPORTANT: Cutter shaft rotates clockwise direction when viewed from encoder side of the clutch.

- a. Cycle the interlock to the cutter homes and confirm there is no error on the screen.
- b. Disconnect the power cord.
- c. Remove the [Rear Cover on page 208](#).
- d. Look to see if the flats on the shaft are horizontal and the crank is at approximately the 2 o'clock position.

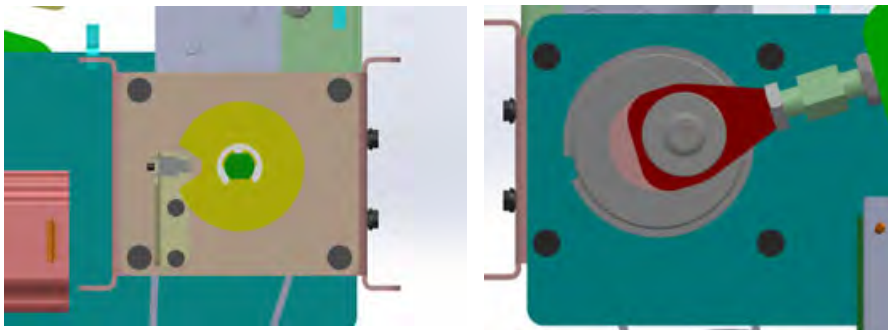

- e. If the clutch shaft is horizontal and the crank is not in the correct position, check that the set screws on the clutch are secure.
- f. If the flats are not horizontal, the clutch must be indexed ($\pm 5^\circ$ from horizontal).

2. To index the shaft to the correct position, remove the spring clip from its groove in the clutch.



3. Move the spring clip towards the pulley to expose the toothed hub.

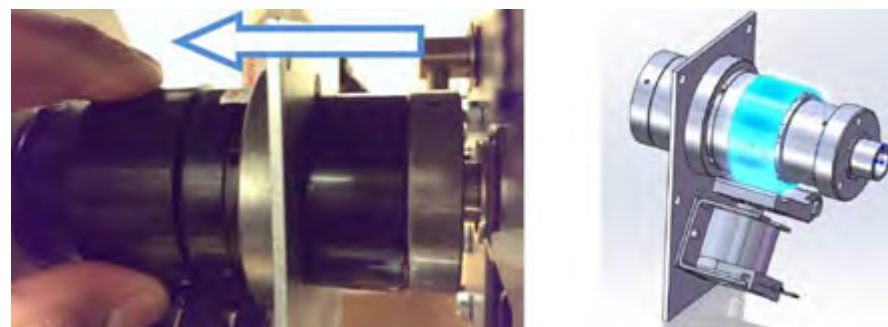

4. Rotate the stop collar.

If the clutch needs to stop earlier, rotate the stop collar clockwise (as viewed from the crank side of the cutter).

If the clutch needs to stop later, rotate the stop collar counter-clockwise.

- Slide the stop collar back to its position and release the pawl.

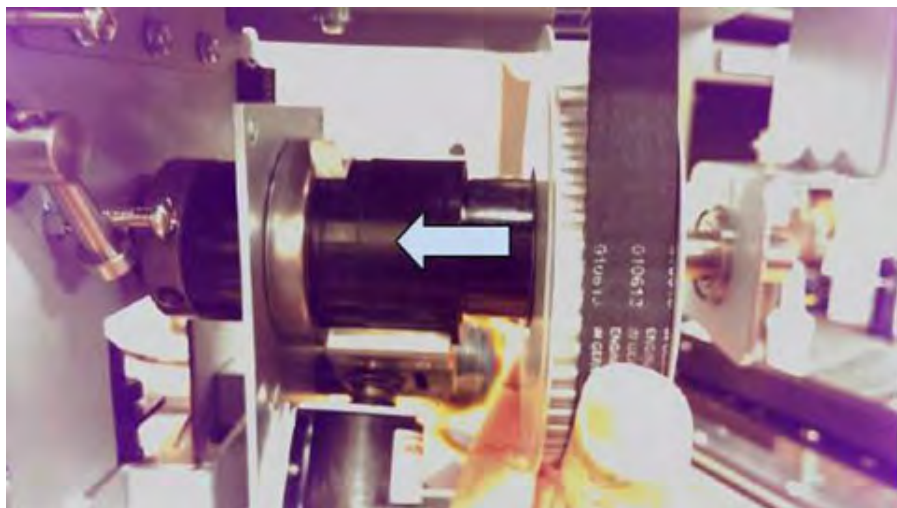

- Manually rotate the pulley in counter-clockwise by holding the pulley to complete a cut cycle.

You may need to use a 10mm wrench on the flats of the shaft to complete a rotation.

- Repeat steps 4-6 until the shaft flat is horizontal and the crank is in the 2 o'clock position.
If the crank is in the 8 o'clock position with a horizontal shaft flat, the clutch is off by 180°.
- Put the spring clip in its groove.
- Connect the power cord.
- Run the [User Functions on page 11](#) to cycle the cutter 10 times.
- After the cut cycles, confirm that the shaft flat returned.
- Install the [Rear Cover on page 208](#).
- Connect the power cord.

Pivot

- Pull out the lamination drawer.
- Use a 5mm Allen wrench to loosen the M6 bolt on top of the cutter.
- Use a 14mm wrench to adjust the pivot to be angled, as shown by the red lines in the figure below.
- Line up the bottom edge of the pivot bolt so that it intersects the bottom edge of the horizontal gap.

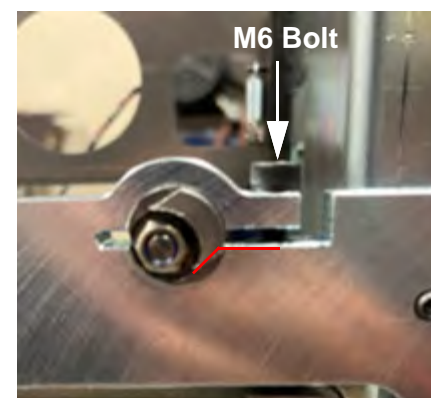

- Ensure the pivot bolt is still flush with the rear surface of the cutter frame. Do not allow the pivot bolt to shift forwards or backwards in the slot. Re-adjust it if necessary before moving to the next step.
- Fully tighten the M6 bolt.
- Ensure the machine is loaded with a film cartridge and ready to feed and cut film.
- Connect the power cord and power on the machine.
- Insert an interlock cheater into the door interlock.



WARNING: Moving Parts, keep hands clear of nips and belts when the interlock cheater is inserted.

10. Run a test cut by selecting "User Functions" on the LCD and then select "Feed, Cut, Purge" from the user function menu.
11. Run a "Jog Film" command from the [Service Menu on page 10](#).
12. Remove the interlock cheater, then inspect the quality of the cut.
13. Inspect the piece of film sticking out of the baffle and proceed accordingly:
 - The cut resulted in a fully cut piece of laminate - no pivot adjustment needed.
 - The cut did not fully break through the film; the cut missed on the rear side (back of the drawer) - repeat steps 3-5, except adjust the pivot angle by turning slightly clockwise.
 - The cut did not fully break through the film; the cut missed on the near side (front of the drawer) - repeat steps 3-5, except adjust the pivot angle by turning slightly counter-clockwise.
14. Run and inspect another test cut until the result is a fully cut piece.

When the film is cut all the way through, the pivot has been successfully adjusted.

NOTE: If the film is cutting successfully on both edges, but is missing in the middle, then a pivot adjustment is no longer required. Instead, the connecting rod length or spring length must be adjusted. See [Connecting Rod Spring on page 233](#).

Connecting Rod Length

IMPORTANT: Only perform this procedure if directed by escalated support.

This procedure outlines how to adjust the connecting rod length on the cutter and can **drastically change the cutting motion of the machine**.

1. Remove the [Rear Cover on page 208](#).
2. Remove the cover on the left side.
3. Locate the connecting rod in the exposed rear of the machine.

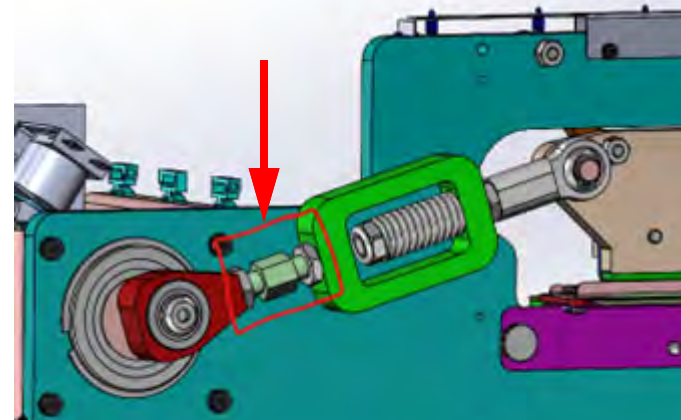

4. Measure and record the distance (D), in millimeters, between the two surfaces shown below. The length should be 32.7mm.



- Use a 17mm combination wrench to loosen the two nuts by turning each nut towards yourself for 3-4 full revolutions.

NOTE: Turning the right nut (#2 on the drawing) may cause the rod to also turn. Wedge a 15mm wrench underneath the green rod frame piece to help it resist the nut's motion.

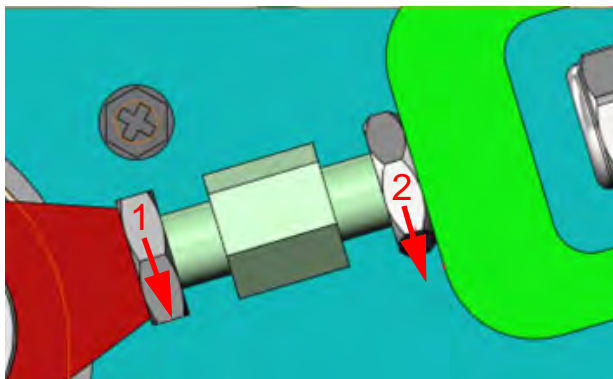

- Compare the length of the rod, which was measured in step 4, to the nominal length of 32.7mm and determine if you will shorten or lengthen the rod.
- Use a 15mm combination wrench on the hex adapter to change the length of the rod.

IMPORTANT: Do not adjust the threaded rod shorter than the nominal. Doing so may result in cutter jams and reduced component life.

To **shorten**, turn the hex adapter towards the cutter frame.

To **lengthen**, turn the hex adapter towards yourself.

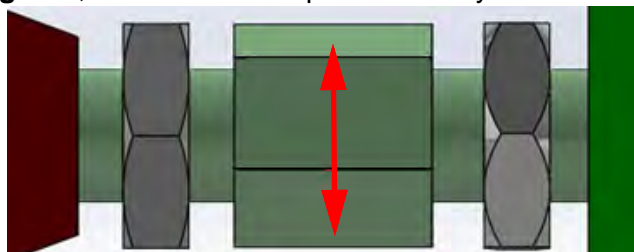

- Measure the distance and continue to adjust until it is at the correct value.
- Tighten nuts #1 and #2 by turning towards the cutter frame, keeping in mind that the rod will need to be wedged with a 15mm wrench.
- Confirm the nuts are tight and that rod does not turn when pushed.
- Measure the distance again to confirm nothing changed when the nuts were tightened.
- Replace the side cover and install the [Rear Cover on page 208](#).
- Connect the power cord and power on the machine.
- Run a test cut by selecting "User Functions" on the LCD and then select "Feed, Cut, Purge" from the user function menu.
- Ensure the cutter successfully cut a piece of film and emptied it into the trim tray.
- If the cutter does not work, proceed to the [Connecting Rod Spring on page 233](#) adjustment.

NOTE: If the cutter does not cut after performing both connecting rod adjustments, contact the next level of support.

Connecting Rod Spring

IMPORTANT: Only perform this procedure if directed by escalated support.

This procedure outlines how to adjust the connecting rod length on the cutter by adjusting the spring and can drastically change the cutting motion of the machine.

1. Remove the [Rear Cover on page 208](#).
2. Remove the cover on the left side.
3. Remove the bent wrench found in front of the lamination drawer.

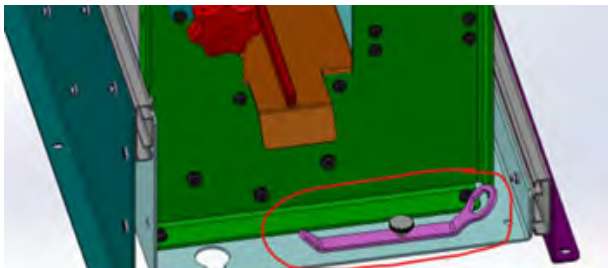

4. Locate the connecting rod spring in the exposed rear of the machine.

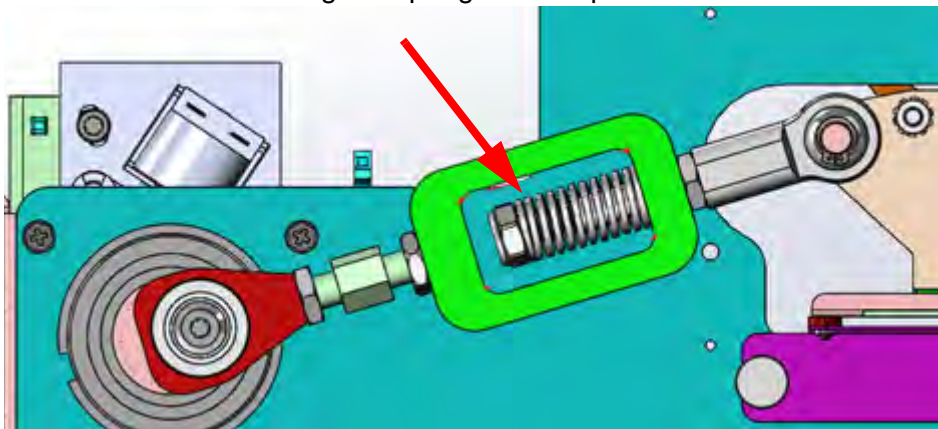

5. Measure the length of the red spring using a pair of calipers, making sure the edges of the calipers are touching the outer ends of the spring. The nominal spring length measure is 36.5mm.



6. If the spring length is incorrect, adjust it back to the nominal position.

IMPORTANT: Do not adjust the spring rod shorter than the nominal. Doing so may result in cutter jams and reduced component life.

7. To adjust, insert the bent wrench over the locknut and either turn the nut towards the frame to loosen the spring or towards you to tighten.

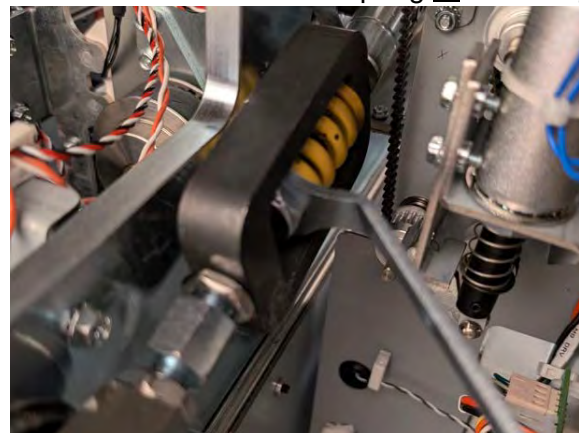

NOTE: Due to the position of the solenoids and driver boards, the wrench can only be turned 90 degrees before taking it off the nut and repositioning it. Each 90-degree rotation should adjust the spring about 0.2mm of length.

8. Use the calipers to check the spring length after every adjustment until it is the correct length.
9. At the front of the machine, pull the laminator drawer all the way out.
10. Confirm that the eye bolt is parallel to the frame and if it is not, use a 17mm combination wrench to straighten.

NOTE: It is usually best to turn the eye bolt slightly more biased towards the frame, because it tends to rotate downwards during operation if it is set completely parallel to the frame.



11. Replace the side cover and install the [Rear Cover on page 208](#).

12. Push the laminator drawer in and close the front door.
13. Connect the power cord and power on the machine.
14. Run a test cut by selecting “User Functions” on the LCD and then select “Feed, Cut, Purge” from the user function menu.
15. Ensure the cutter successfully cut a piece of film and emptied it into the trim tray.
16. If the cutter does not work, perform the adjustment for [Connecting Rod Length on page 231](#).

NOTE: If the cutter does not cut after performing both connecting rod adjustments, contact the next level of support.

Lamination Drawer

Alignment Pin

Perform this procedure if the lamination drawer alignment is not centered in the pocket. When the alignment is off, the trim diverter may hit the cutter, or the alignment carriage may hit the acceleration panel.

1. Remove the [Rear Cover on page 208](#).
2. Loosen the alignment pin screw with a 7mm wrench.

IMPORTANT: Do NOT remove the screw.

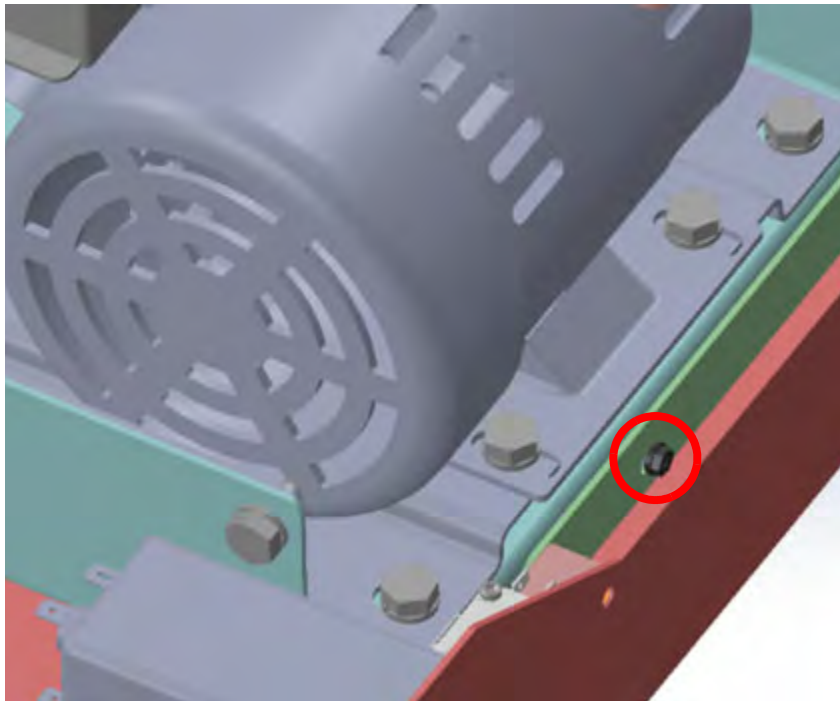

3. Push the drawer in the direction required to center it in the paper path.

You may need to use a tool, such as a flathead screwdriver, as a level to adjust the position. Slide the tool between the drawer and the drawer rail brackets. **Pushing it from other locations could damage the machine.**

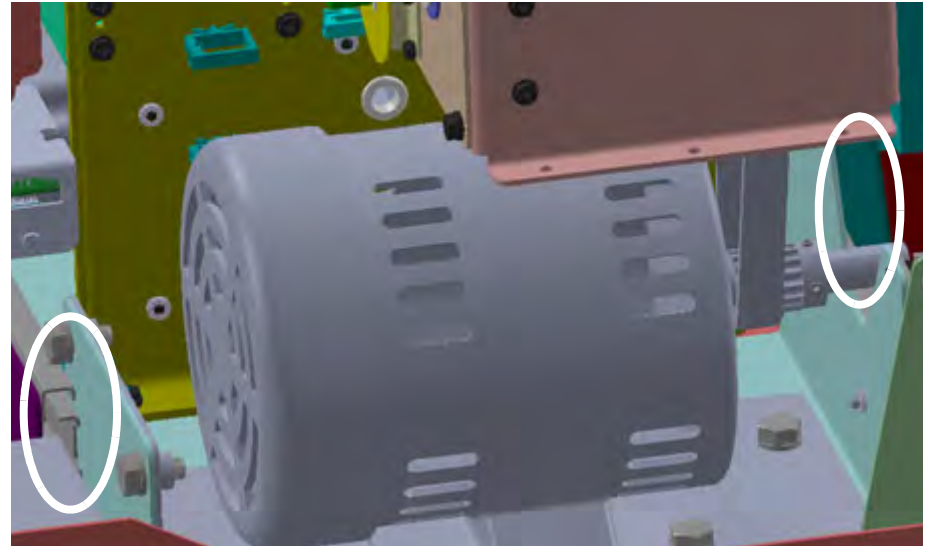

4. While holding it in position, tighten the screw securing the pin.
5. Check the alignment and, if necessary, repeat steps 2-4 until correct.
6. Install the [Rear Cover on page 208](#).
7. Connect the power cord.

Drawer Switch

If the machine displays an error that the lamination drawer is out when it is not, the switch needs to be adjusted.

1. Remove the [Rear Cover on page 208](#).
2. Open the front cover and pull out the drawer so that the switch is not engaged.
3. Loosen the jam nut using a 7mm wrench.

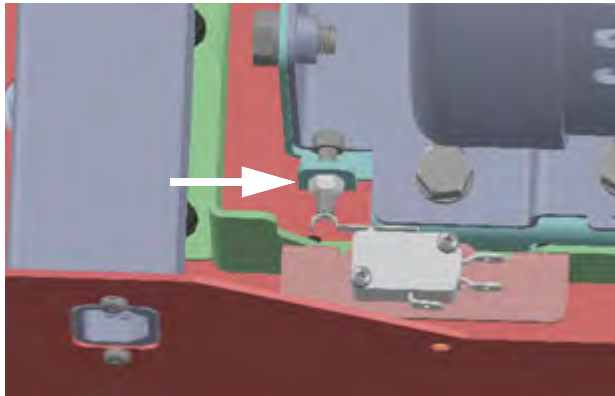

4. Push the lamination drawer in.
5. Use a 5mm hex wrench to adjust the screw so it only activates the switch when the drawer is secured by the latch.
The switch will click when pressed.
6. Tighten the jam nut.
7. Install the [Rear Cover on page 208](#).
8. Connect the power cord and power on the machine.
9. Confirm that there is no error message displayed.

Cut Stick

1. Open the front door and pull out the lamination drawer.
2. Remove the (4) thumbscrews from this baffle and set aside



3. Remove the cutter out-feed baffle and set aside.
In the exposed cutter slot you will find the garolite cut stick.
4. Remove the cut stick, **keeping it in the same orientation that it was in the machine.**



5. Inspect the cut stick for thin grooves.
Each cut stick can be used four times total. Twice on each side before flipping upside down and using twice again. When you remove the stick, there must be a groove in position 1.
6. Check if there is a groove in position 2 and if not, rotate the stick so that position 2 is facing the cutter.

If positions 1 and 2 already have grooves, check to see if 3 or 4 on the bottom side of the side are free.

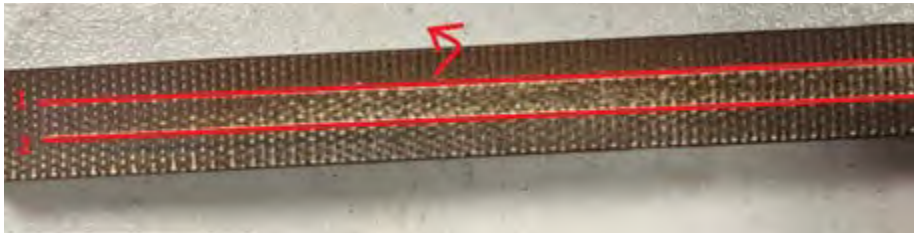

7. If all four positions have grooves, obtain a new cut stick.
8. Slide the cut stick on top of the backer stick.
9. Install the cutter out-feed baffle.
10. Install and tighten the (4) thumbscrews.
11. Push in the drawer and close the door.
12. Connect the power cord and power on the machine.
13. On the UI, go to Settings > Cut Stick and select reset stick cycles.
The stick cycles should now read 0.
14. Run a test cut by selecting "User Functions" on the LCD and then select "Trim Film and Eject" from the user function menu.
15. Continue to run test cuts until the blade cuts fully through the film.

Locking Mechanism Springs

1. Open the front door and pull out the lamination drawer, and open the locking mechanism using the green handle.
2. Loosen the top jam nut using a 10mm wrench.

3. Adjust the bottom jam nut to compress/decompress the spring using a 10 mm wrench.

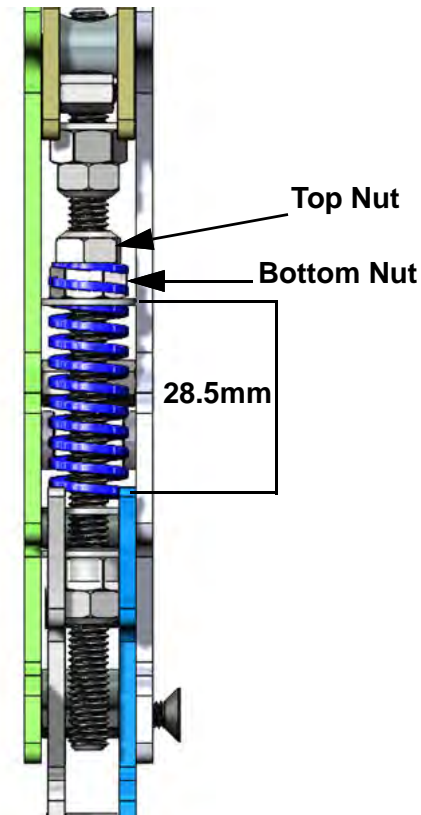

4. The compressed spring length should be set to 28.5. This needs to be measured inside of the washers (see image) using a pair of calipers with the locking mechanism engaged (in the downward position). If the spring length is incorrect, open the mechanism and repeat step (3).
5. Tighten the top jam nut without changing the spring compression.
6. Repeat on the other locking mechanism.
7. Push in the drawer and close the door.
8. Connect the power cord.

Drawer Latch

1. Remove the [Rear Cover on page 208](#).
2. Remove the [Downstream Rear Side Cover on page 118](#).
3. Locate the drawer latch.



4. Push the laminator drawer out, slightly, until the latch catch is exposed.
5. Loosen, but do not remove, the (2) screws on the catch.



6. Push the laminator in, ensuring the latch and hook are fully mated.
7. Once the latch is fully engaged, use the through hole to tighten the bottom screw of the catch.



8. Pull out and push in the laminator drawer to ensure the drawer is secured by the latch.
9. Confirm the drawer screw comes in contact with the switch.

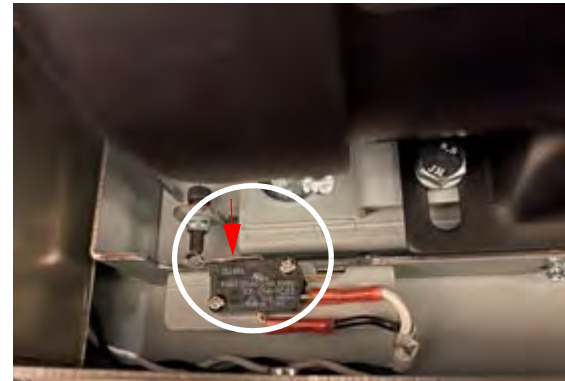

10. If no contact is being made between the switch and screw, adjust the [Drawer Switch on page 236](#).
11. Connect the power cord.

Sensors

S1B - Cutter

IMPORTANT: Perform this adjustment only after confirming S1B is working. See [User Functions on page 11](#).

Perform this adjustment if the cutter is not activating between sheets or if film, without paper, is causing the machine to read blocked.

1. With the power on, check the voltage across TP-1B and TP1BGND on the break out board using a multimeter. It should be set to a voltage reading of approximately 1.3V.

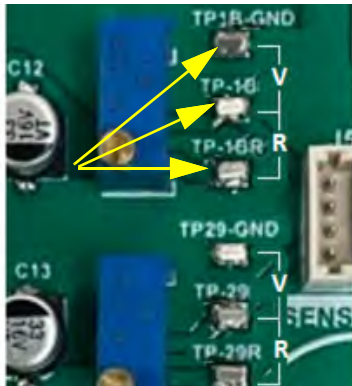

2. If the voltage is incorrect, turn the power off and move on to checking the resistance.

This can be measured between TP-1B and TB-1BR using a multimeter. An ohm reading from 350-500 ohms should be measured. If the resistance reading is not within this range, then that is the cause of the incorrect voltage from step 3.

3. Adjust the screw on the potentiometer next to the test points until the correct resistance range is achieved.
4. With the power on and door closed, re-check the voltage across TP1B-GND and TP-1B is close to 1.3V.

5. Check that the S1B reads unblocked in the service sensor menu when nothing is blocking it.
6. Block the sensor with a piece of **film**. It should still read unblocked. If the film marked read as blocked, lower the resistance in increments of 2-3 Ohms until the film is not detected by the sensor. The machine must be powered off before reading the resistance or you will get an incorrect reading.
7. Block the sensor with a piece of **paper**. It should read blocked. If the paper marked read as unblocked, raise the resistance in increments of 2-3 Ohms until the paper is detected by the sensor. The machine must be powered off before reading the resistance or you will get an incorrect reading.

Parts List

PL 1.1 Final Assembly

ITEM	Part #	DESCRIPTION	QTY'
1	7726001	FINAL ASSEMBLY, XEROX 115V	1
	7726101	FINAL ASSEMBLY, XEROX 230V	1
2	7726301	FINAL ASSEMBLY, STACKER, OLY, XEROX	1
3	7726201	FINAL ASSEMBLY, BRIDGE, XEROX	1
4	7726210	ASSEMBLY, BRIDGE BASE, OLY, XEROX	1

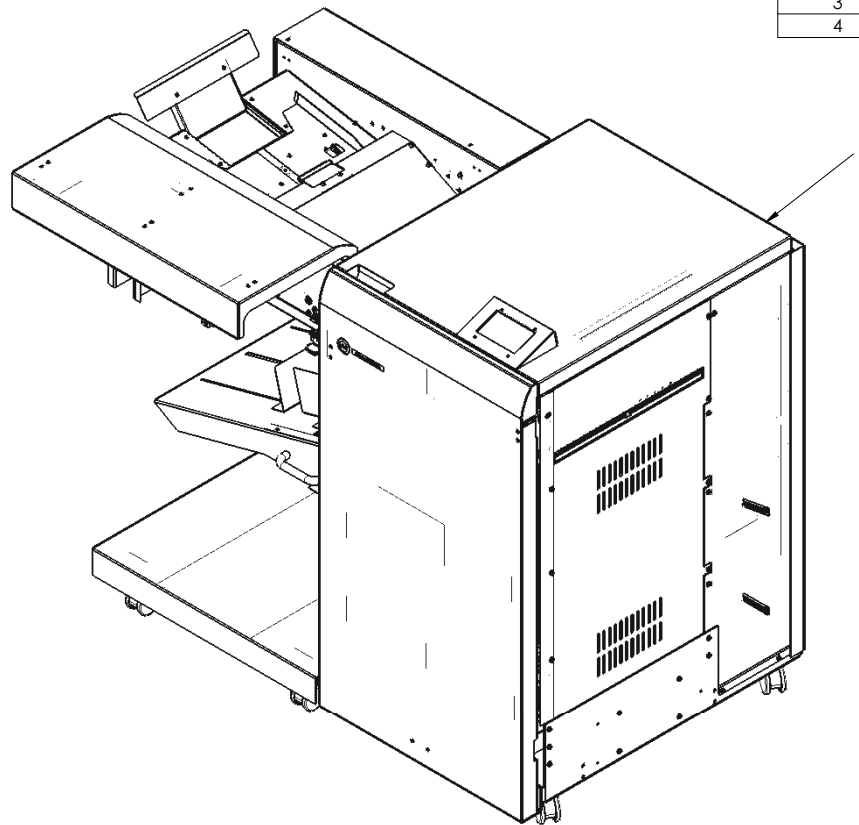

NOTES:

- 1. "PART NUMBERS FOR REFERENCE ONLY"
- 2. ITEMS 1 THRU 4 ARE NOT SERVICE ASSEMBLIES

PL 1.2 Covers

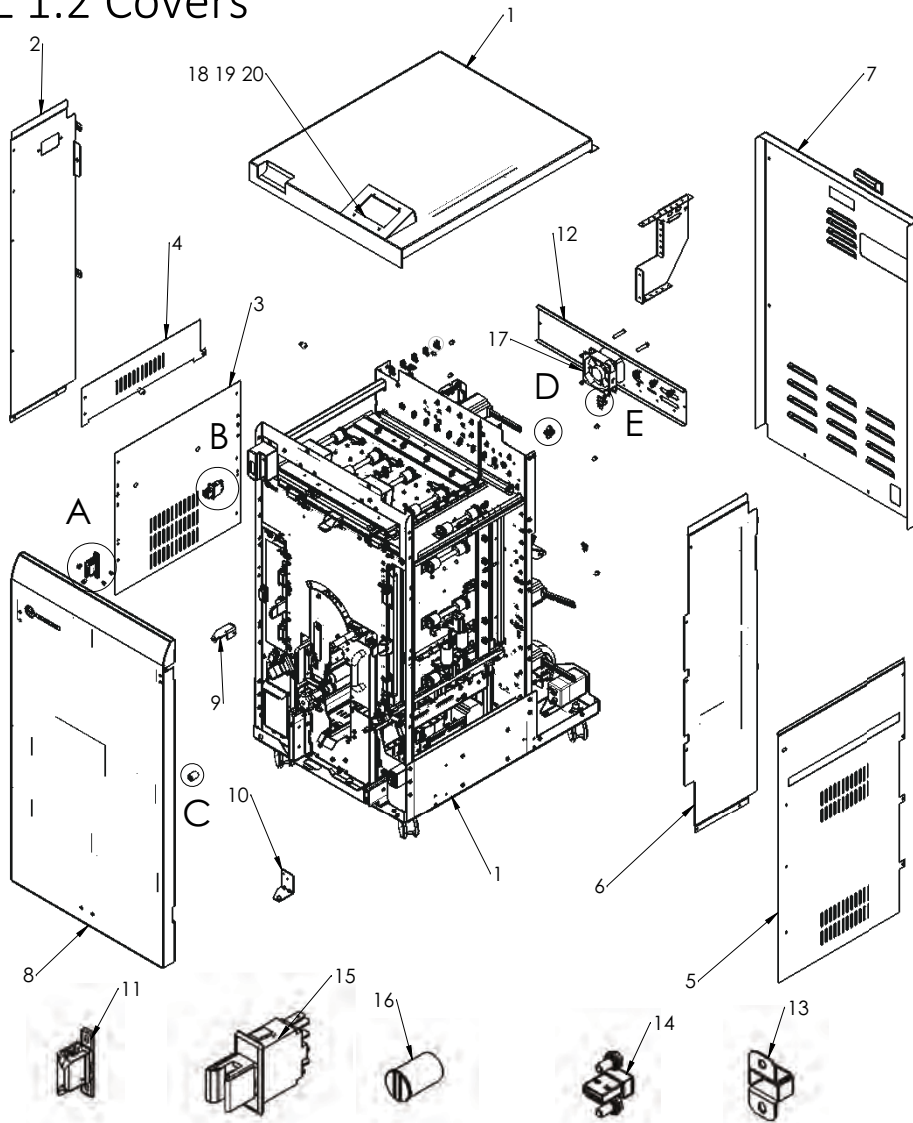

ITEM NO.	PART NUMBER	DESCRIPTION	QTY.
1	Z7726141	COVER, TOP, WELDMENT ASSEMBLY, OLY, XEROX	1
2	Z7726145	COVER, SIDE, UPSTREAM, REAR, OLY, XEROX	1
3	Z7726162	COVER, SIDE FRAME, UPSTREAM, BOTTOM, OLY, XEROX	1
4	Z7726177	COVER, SIDE, UPSTREAM, UPPER, OLY, XEROX	1
5	Z7726146	COVER, SIDE FRAME, DOWNSTREAM, OLY, XEROX	1
6	Z7726164	COVER, SIDE, DOWNSTREAM, REAR, OLY, XEROX	1
7	7726160	COVER, REAR, ASSEMBLY, OLY, XEROX	1
8	7726147	FRONT DOOR ASSEMBLY, OLY, XEROX	1
9	Z7726152	BRACKET, FRONT DOOR HINGE, TOP, OLY, XEROX	1
10	7715570	BRACKET, FRONT DOOR, HINGE, BOTTOM	1
11	7706486	LATCH, PUSH TO CLOSE, SOUTHCO	2
12	Z7726172	EXHAUST FAN, BRACKET, ASSY, OLY, XEROX	1
13	7715828	COVER, USB DRIVE	2
14	7715684	DRIVE, USB STICK, FLASH DRIVE	1
15	7610501	INTERLOCK SWITCH	1
16	7706447	MAGNET, FRONT DOOR	1
17	7715267	FAN, EXHAUST	1
18	7723665	LCD, TOUCHSCREEN, 4.3."	1
19	7723646	ADAPTER PCB, LCD TOUCHSCREEN	1
20	7724422	RIBBON CABLE, LCD	1
21	Z7729801	KIT, SCREWS, OLY	-

DETAIL A

SCALE 1 : 4

DETAIL B

SCALE 1 : 2

DETAIL C

SCALE 1 : 2

DETAIL D

SCALE 1 : 2

DETAIL E

SCALE 1 : 2

PL 2.2 Frame Assembly - Front

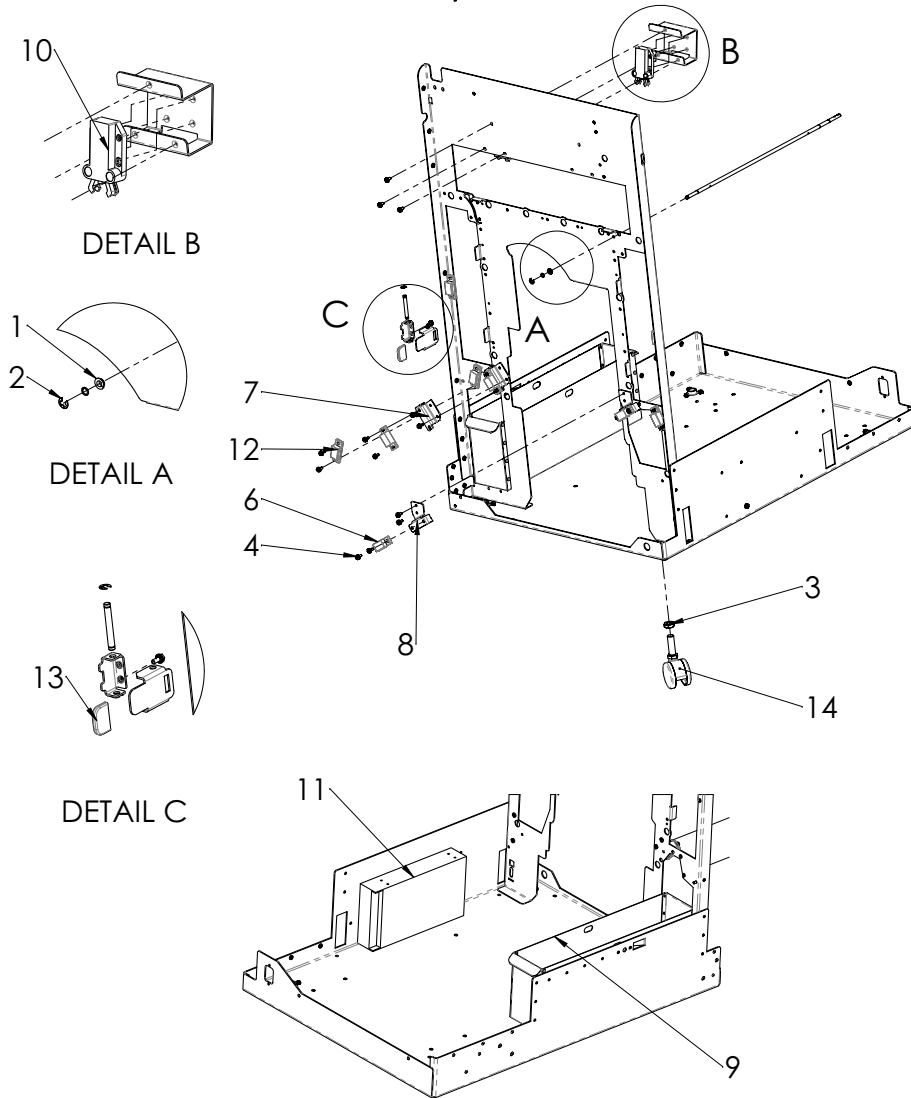

ITEM	Part #	DESCRIPTION	QTY
1	Z7729802 1821209	SNAP-IN BEARING, 6MM ID	2
2	Z7729802 1822202	E-RING, JE-5	4
3	Z7729801 1823711	JAM NUT, M16X2.0	4
4	1823903	SCREW, PHILLIPS HX HD W/SEMS M4 X 8	4
5	1821606	SCREW, PHILLIPS PAN HD, M3X10	12
6	7715195	MAGNET, PANEL, OPEN, STRONG	2
7	Z7725318	BRACKET, MAGNET STANDOFF, ASSY	1
8	Z7725532	BRACKET, MAGNET	1
9	Z7725388	TRIM TRAY, WELDMENT, OLYMPIA	1
10	7715650	LATCH, BYPASS	2
11	7715637	POWER SUPPLY, 24V, MW SP 480	1
12	7715789	MAGNET, PANEL, OPEN, WEAK	4
13	Z7725181	CAP, RUBBER .032x1.00, BLUE	5
14	7723799	CASTER, ADJUSTABLE, ASSY, KM	4

PL 2.3 Frame Assembly – Rear

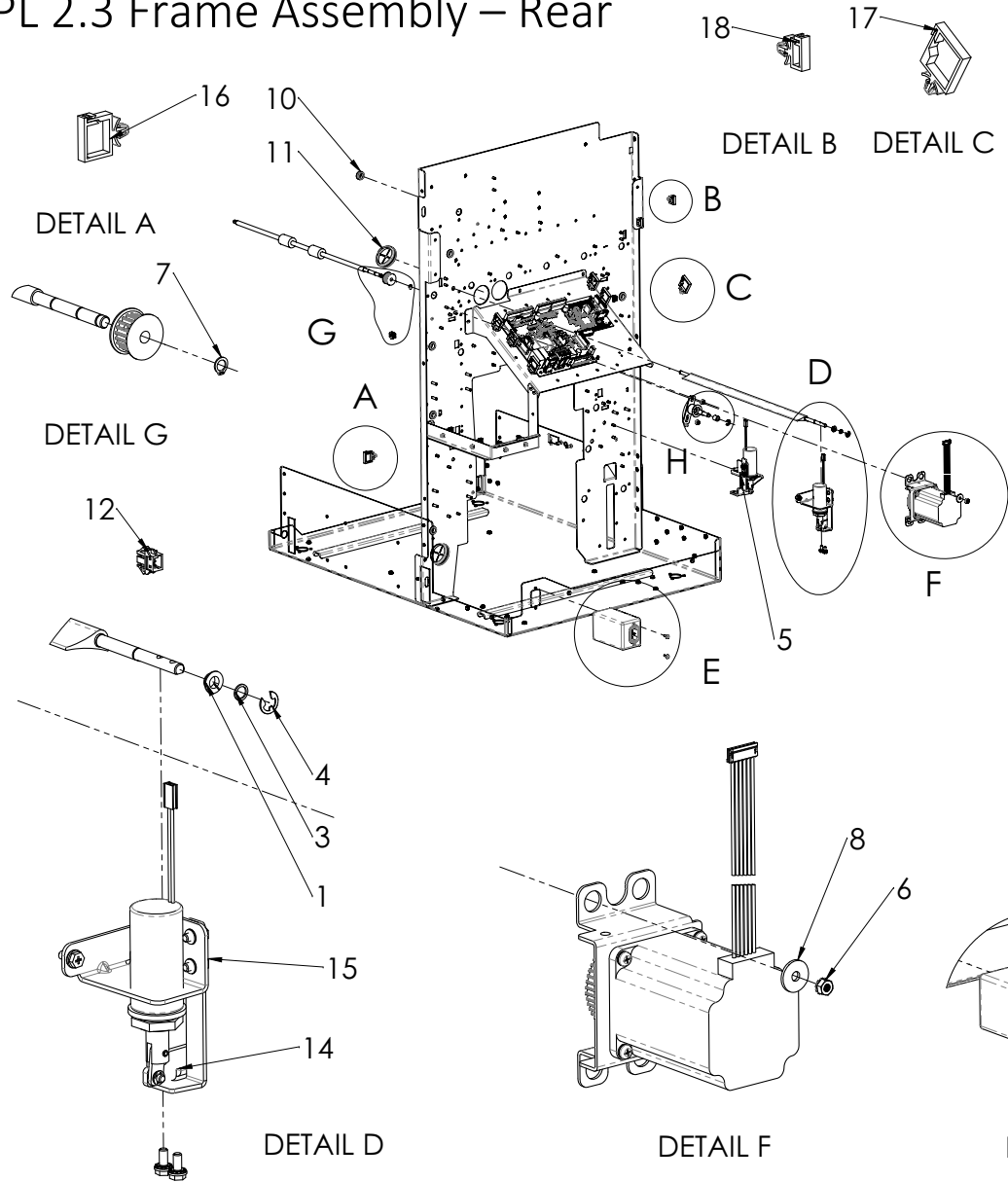

ITEM	Part #	DESCRIPTION	QTY
1	Z7729801 1821209	SNAP-IN BEARING, 6MM ID	4
2	Z7729801 1821611	SCREW, PHILLIPS HD W/SEMS, M3X10	2
3	Z7729801 1822005	WASHER, FLAT, 6.025 X 8 X 0.75	4
4	7729802 1822202	E-RING, JE-5	7
5	7725524	SOLENOID, BRACKET, TRIM SUB ASSEMBLY, OLY	1
6	Z7729801 1824001	NUT, KEPS M4	24
7	Z7729802 1825501	RETAINING RING, 6MM SHAFT	7
8	Z7729801 1925044	WSHR, .192 ID X .625 OD X .060 T	24
9	1952208	SPACER, TIMING BELT IDLERS, BRONZE	5
10	1954011	GROMMET, 3/8 I.D X 1/2 O.D	9
11	1954032	GROMMET, 1 1/4 I.D. X 1 1/2 O.D.	2
12	Z7729803 7712703	WIRE HEADER CONNECTOR, 2 POS	4
13	7715383	ROLLER, IDLER, DRIVE ASSY	7
14	Z7729803 7715390	WIRE CLAMP, EDGE	4
15	7715813	SOLENOID, BRACKET, DIVERTER, SUB ASSEMBLY	1
16	Z7729803 7715818	WIRE SADDLE, MEDIUM, LOCKING TOP, V-0	-
17	Z7729803 7715819	WIRE SADDLE, LARGE, LOCKING TOP, V-0	-
18	Z7729803 7715817	WIRE SADDLE, SMALL, LOCKING TOP, V-0	-

PL 2.4 Frame Assembly - Drive rollers

ITEM	Part #	DESCRIPTION	QTY
1	7715093	ROLLER ASSY, DRIVE	10
2	7725499	ROLLER ASSY, TRIM	1
3	1821116	BEARING, BALL, FLANGE 6X13X5, SUJ2	20
4	Z7729801 1822005	WASHER, FLAT, 6.025 X 8 X 0.75	24
5	Z7729802 1822202	E-RING, JE-5	24
6	Z7725455	PULLEY, TIMING, 3MM GT2, 20 GROOVES	2
7	Z7725456	PULLEY, TIMING, 3MM GT2, 16 GROOVES	1
8	7715204	PULLEY, TIMING, 2MM 2GT, 30T	9
9	1825501	RETAINING RING, 6MM SHAFT	24

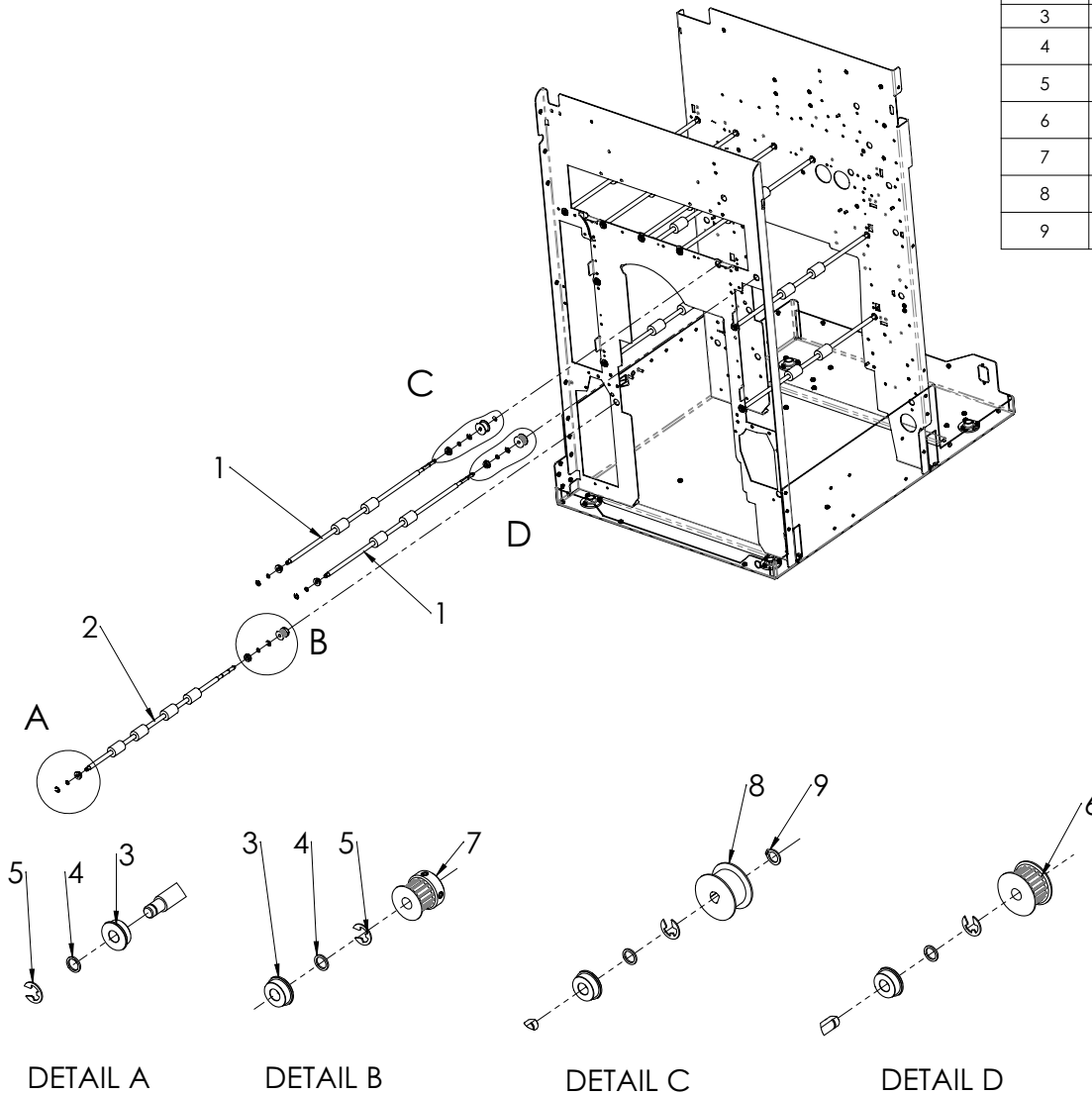

PL 2.5 Frame Assembly – Internal Parts

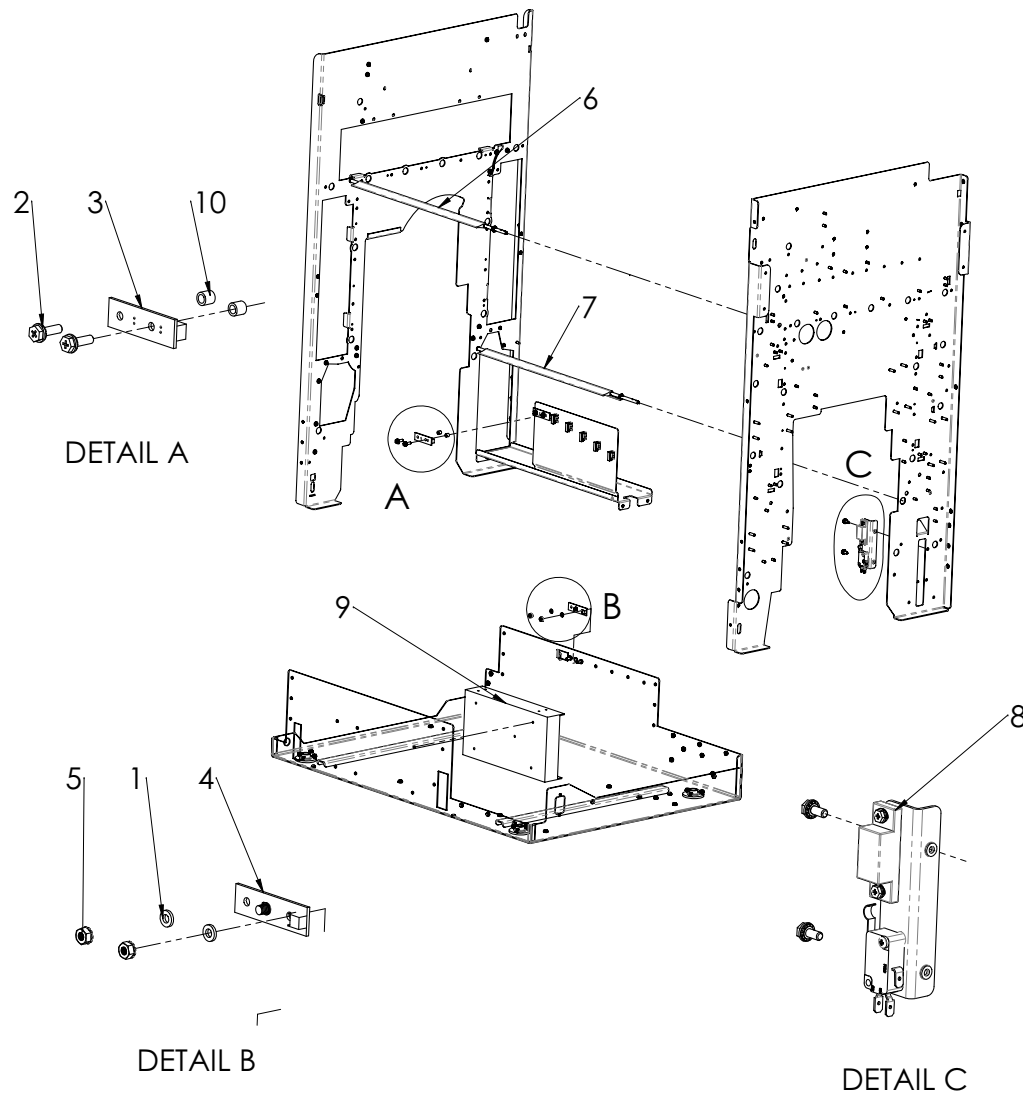

ITEM	Part #	DESCRIPTION	QTY
1	Z7729801 1822108	WASHER, FLAT, 4.1X8X1.5	4
2	Z7729801 1823915	SCREW, PHILLIPS HX HD W/SEMS M4 X 12	2
3	7711970	EMITTER	1
4	7711973	RECEIVER	1
5	Z7729801 1824001	NUT, KEPS M4	2
6	7715131	BYPASS DIVERTER	1
7	Z7725529	TRIM DIVERTER ASSY	1
8	7715186	CHIP TRAY SENSOR MOUNT ASSY	1
9	7715637	POWER SUPPLY, 24V, MW SP 480,	1
10	Z7725392	SPACER, 4X6X9	2

PL 2.9 Belts

ITEM	Part #	DESCRIPTION	QTY
1	7725533	BELT, 539T, 2MM GT2, 6W	1
2	7725534	BELT, 197T, 3MM GT3, 6W, 2-SIDED	1
3	7725455	PULLEY, TIMING, 3MM GT2, 20 GROOVES	1
4	7725456	PULLEY, TIMING, 3MM GT2, 16 GROOVES	1
5	7715204	PULLEY, TIMING, 2MM 2GT, 30T	1
6	7715245	TENSIONER ASSEMBLY	1

PL 3.2 Paper Path- Entrance Idler Panel

ITEM	Part #	DESCRIPTION	QTY
1	7715103	ROLLER ASSY, IDLER	3
2	7724133	MODULE, SOLENOID, DISENGAGING ROLLER	2
3	7715291	SENSOR AND BRACKET ASSY	3
4	Z7725181	CAP, RUBBER .032x1.00, BLUE	2
5	7717410	SPRING, TRANSPORT IDLR ROLLER	6
6	7715382	BEARING HOUSING	6
7	Z7725182	HANDLE ASSY, IDLER PANELS, BLUE	1
8	7715625	WIRE SADDLE, SHORT	1
9	Z7726432	PANEL, WELDMENT, IDLER, ENTRANCE, OLY	2
10	7714679	GROUND STRAP, M4	1

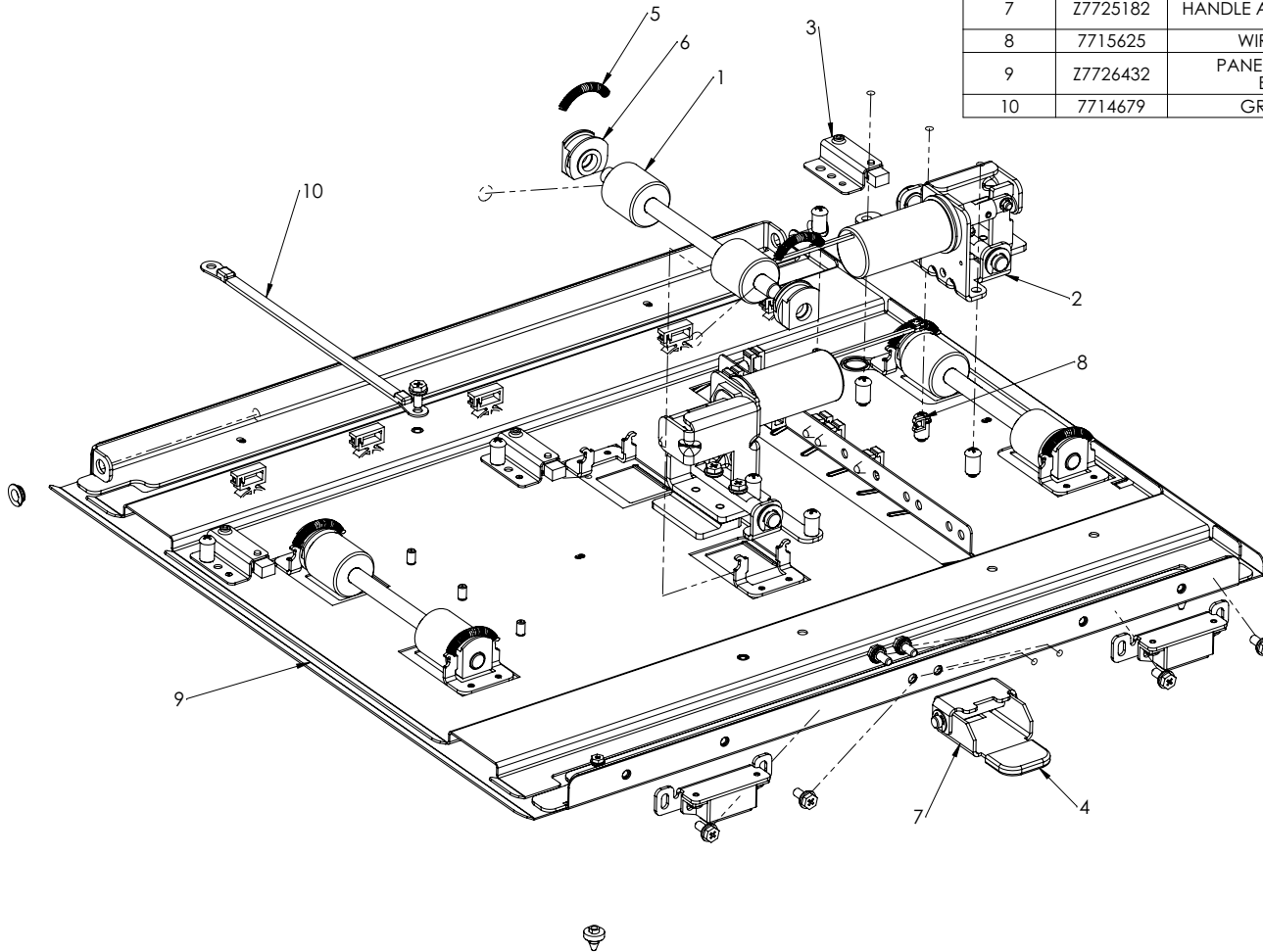

PL 3.3 Paper Path- Entrance Corner Panel

ITEM	Part #	DESCRIPTION	QTY
1	7725181	CAP, RUBBER .032x1.00, BLUE	1
2	7725479	PANEL ASSEMBLY, LOWER, EXIT, OLY	1
3	7718630	GROUND STRAP, M4	1
4	7715893	BRUSH, ANTI STATIC, SUS, LONG	1

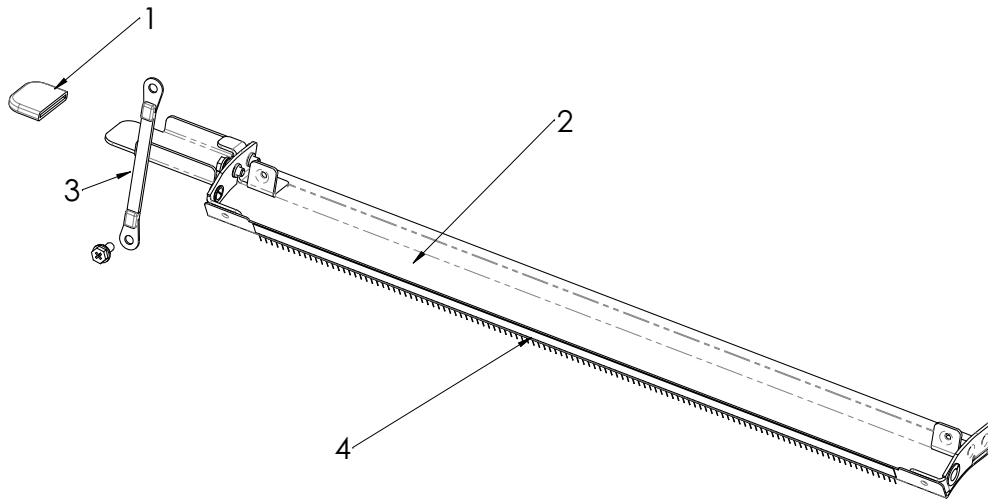

PL 3.4 Paper Path- Exit Idler Panel

ITEM	Part #	DESCRIPTION	QTY
1	7715103	ROLLER ASSY, IDLER	2
2	7715291	SENSOR AND BRACKET ASSY	2
3	7717410	SPRING, TRANSPORT IDLER ROLLERS	4
4	7725182	HANDLE ASSY, IDLER PANELS, BLUE	1
5	7715382	BEARING HOUSING ASSY	4
6	7725476	PANEL WELDMENT, IDLER, EXIT, OLY	1
7	7714679	GROUND STRAP, M4	1
8	7725181	CAP, RUBBER .032x1.00, BLUE	1
9	7729801 7715629	SCREW, BARREL, M4, 7MM DEEP	2

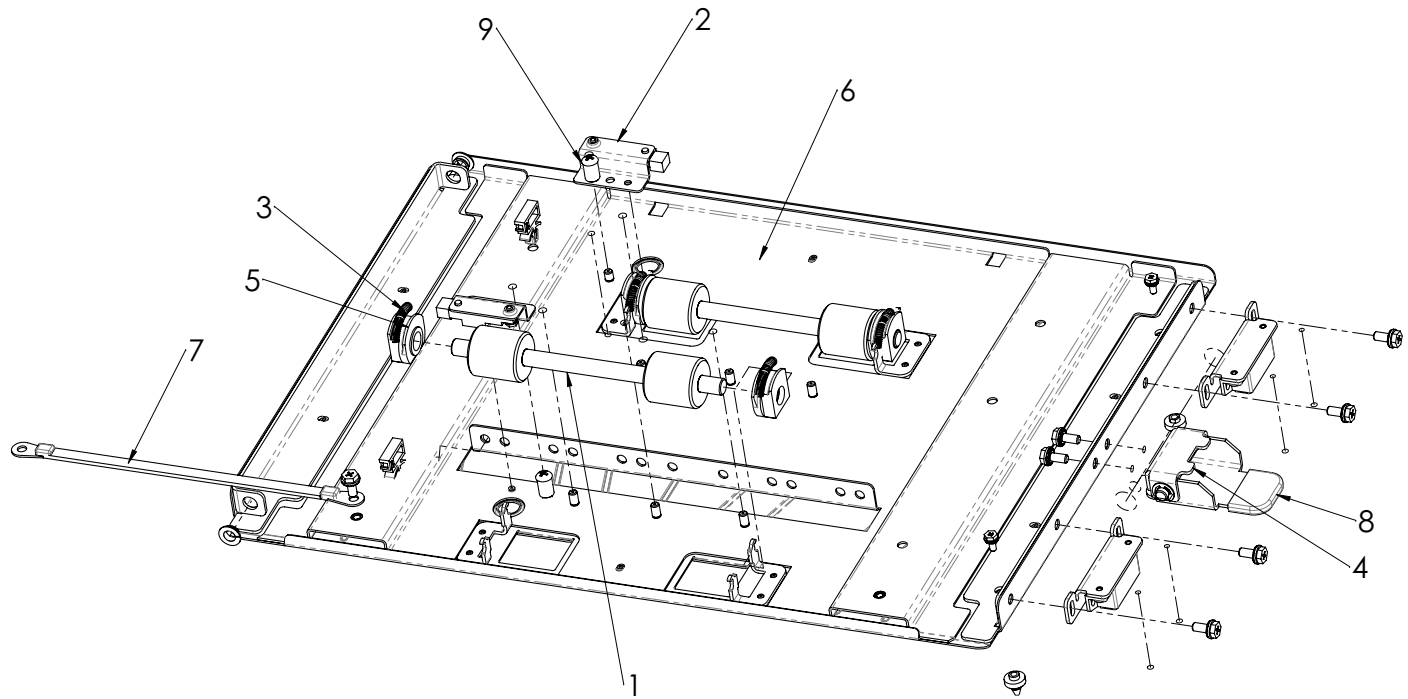

PL 3.5 Upper Bypass Panel

ITEM	Part #	DESCRIPTION	QTY
1	7718594	BRUSH, ANTI-STATIC	1
2	7717410	SPRING, TRANSPORT IDLER ROLLERS	10
3	7715382	BEARING HOUSING ASSY	10
4	Z7725182	HANDLE ASSY, IDLER PANELS, BLUE	1
5	7715627	SENSOR AND BRACKET ASSY, S1	1
6	Z7729801 7715629	SCREW, BARREL, M4, 7MM DEEP	4
7	Z7726470	PANEL WELDMENT, BYPASS, UPPER, OLY	1
8	7714679	GROUND STRAP, M4	1
9	Z7725181	CAP, RUBBER .032x1.00, BLUE	1
10	7715103	ROLLER ASSY, IDLER	5
11	7715291	SENSOR AND BRACKET ASSY.	3
12	1824002	1284002 NUT, KEPS, M3	1

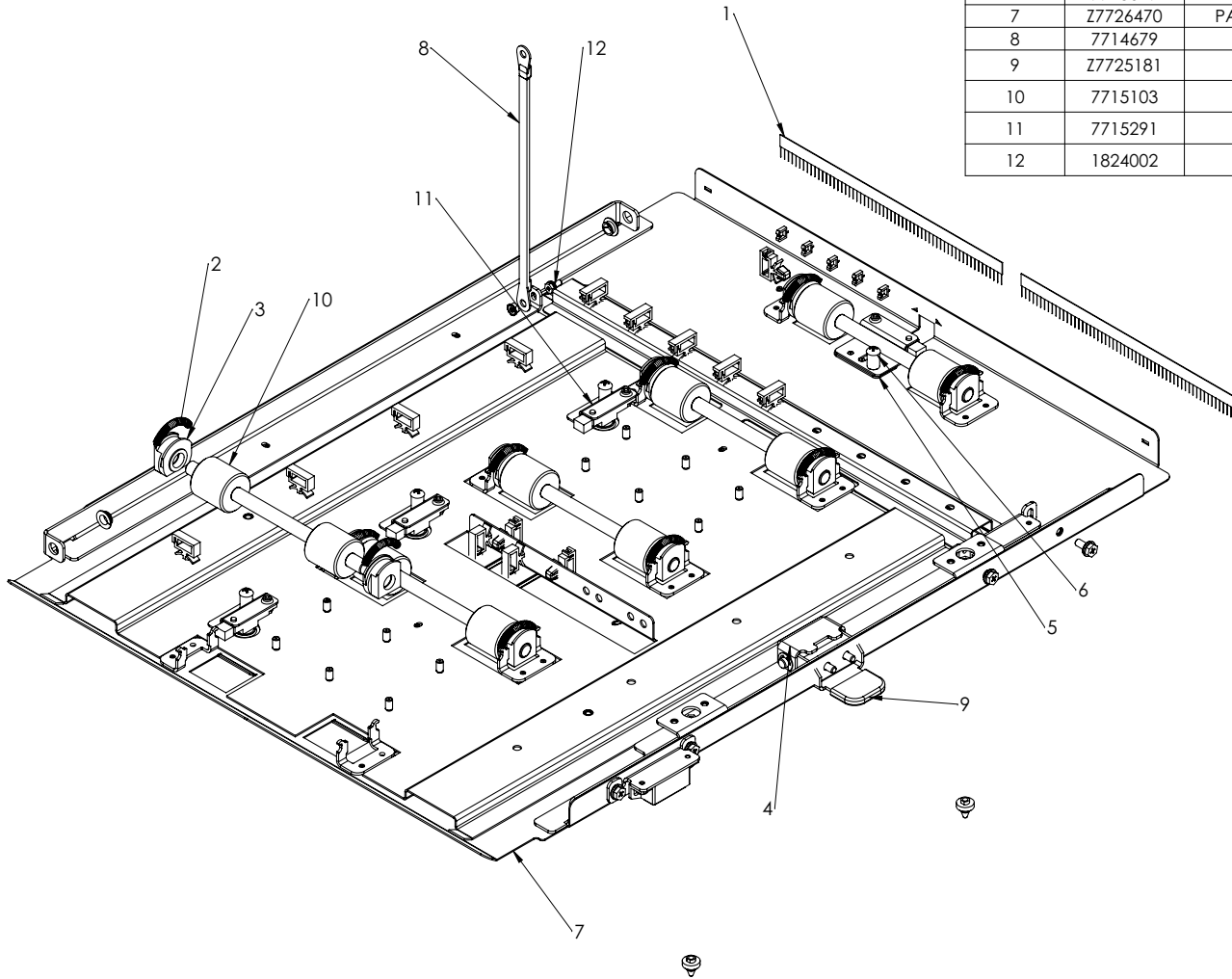

PL 3.5 Paper Path- Upper Bypass Panel

ITEM	Part #	DESCRIPTION	QTY
1	7718594	BRUSH, ANTI-STATIC	1
2	7717410	SPRING, TRANSPORT IDLER ROLLER	12
3	7715382	BEARING HOUSING ASSY	12
4	Z7725182	HANDLE ASSY, IDLER PANELS, BLUE	1
5	7715627	SENSOR AND BRACKET ASSY,S1	1
6	Z7729801 7715629	SCREW, BARREL, M4, 7MM DEEP	4
7	Z7725459	PANEL WELDMENT, BYPASS, UPPER, OLY	1
8	7714679	GROUND STRAP, M4	1
9	Z7725181	CAP, RUBBER .032x1.00, BLUE	1
10	Z7729801 1822117	WASHER, 3.2ID, 8OD, 0.75MM THICK	1
11	7715103	ROLLER ASSY, IDLER	6
12	7715291	SENSOR AND BRACKET ASSY,	3
13	1824002	1824002 NUT, KEPS, M3	1
14	7715619	PIN, PANELS GUIDE, BULLET NOSE, SPARTA	2

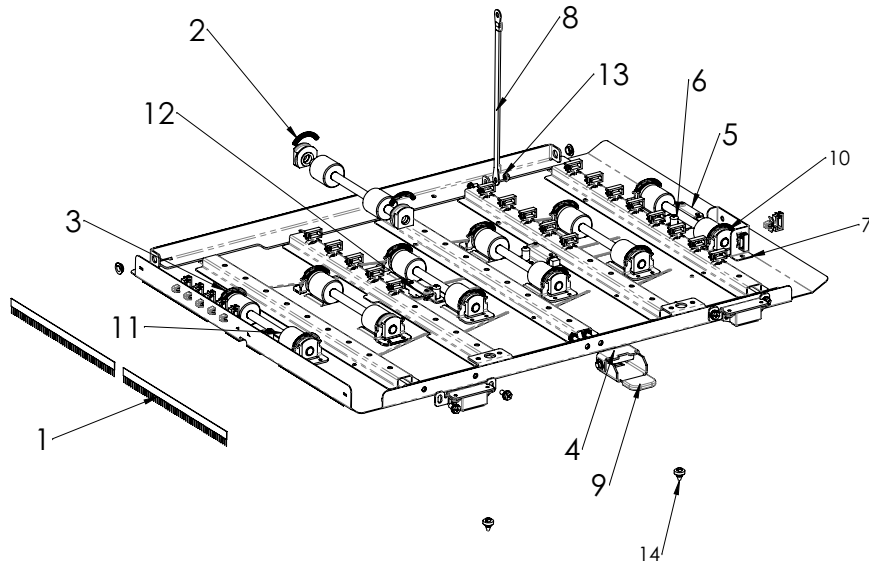

PL 3.6 Paper Path- Disengaging Roller Solenoid

ITEM	Part #	DESCRIPTION	QTY
1	7724134	MODULE, SOLENOID, DISENGAGING ROLLER	2

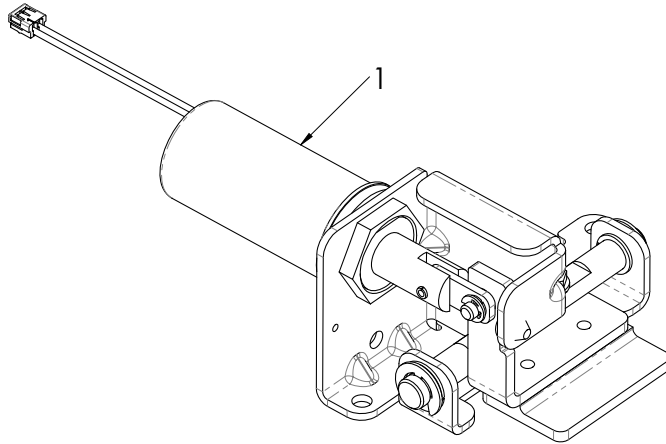

PL 4.1 Drawer - Cutter

ITEM	Part #	DESCRIPTION	QTY
1	Z7725215	BLADE, CUTTER, OLY	1
2	Z7725231	LINK, ARM, CUTTER, ASM	2
3	Z7725542	CONNECTING ROD ASSY, SPRING, OLY	1
4	Z7725250	OUTFEED WELDMENT, CUTTER	1
5	Z7729804	KIT, CLUTCH, OLYMPIA	1
6	Z7729805	KIT, PULLEY, OLYMPIA	1
7	Z7725243	CRANK, OLYMPIA	1
8	Z7725266	DISC SENSOR KIT	1
9	7725244	BEARING, FLANGED, 30X62X16	1
10	Z7725720	BRACKET, SENSOR, S22	1
11	Z7725692	MOTOR MOUNT ASSEMBLY, CUTTER, OLY, 115V kit	1
12	Z7729814	CUT STICK PACK OF 5	1

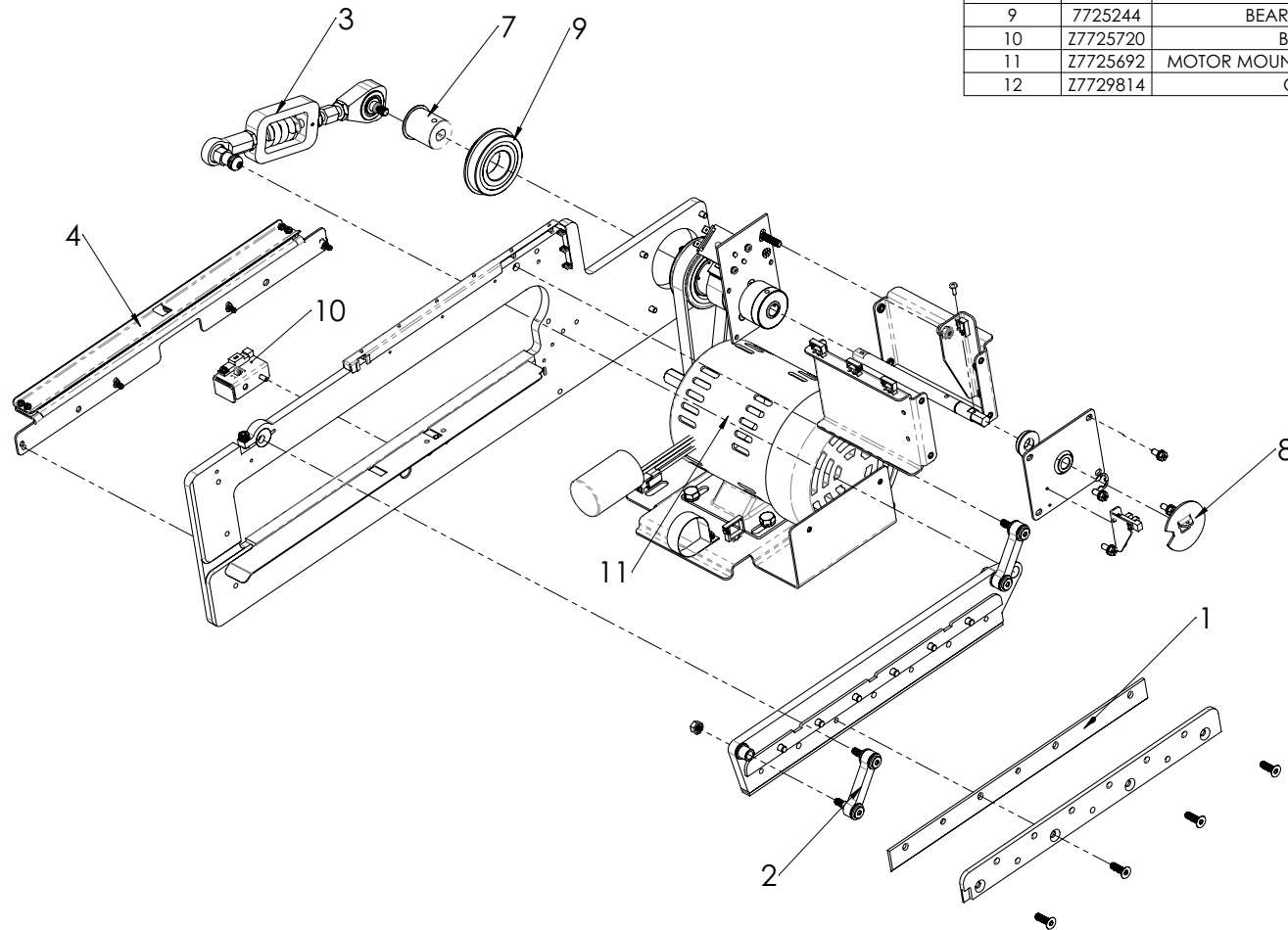

PL 5.1 Drawer – Laminator

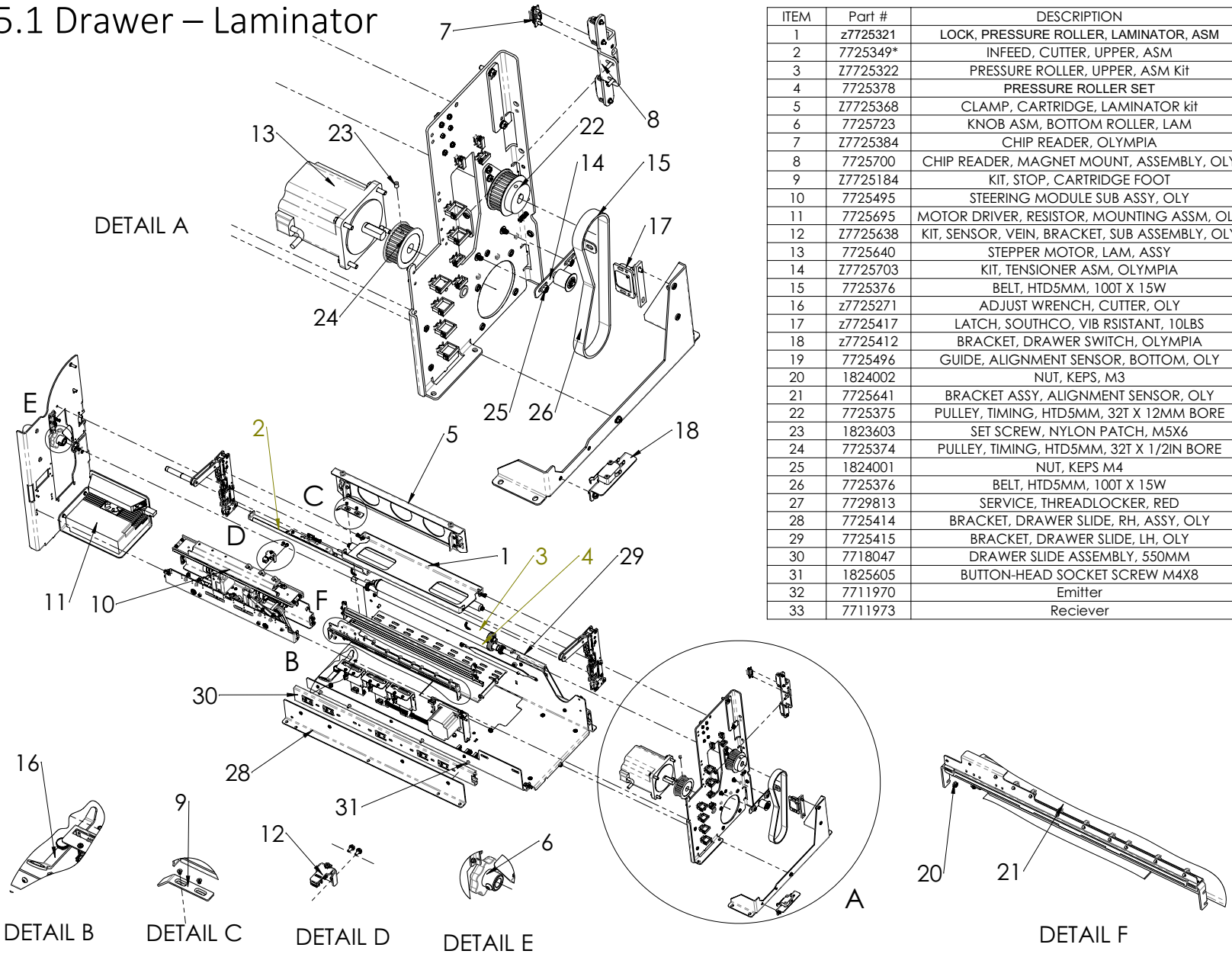

ITEM	Part #	DESCRIPTION	QTY
1	z7725321	LOCK, PRESSURE ROLLER, LAMINATOR, ASM	1
2	7725349*	INFEED, CUTTER, UPPER, ASM	1
3	Z7725322	PRESSURE ROLLER, UPPER, ASM KIT	1
4	7725378	PRESSURE ROLLER SET	1
5	Z7725368	CLAMP, CARTRIDGE, LAMINATOR kit	1
6	7725723	KNOB ASM, BOTTOM ROLLER, LAM	1
7	Z7725384	CHIP READER, OLYMPIA	1
8	7725700	CHIP READER, MAGNET MOUNT, ASSEMBLY, OLY	1
9	Z7725184	KIT, STOP, CARTRIDGE FOOT	1
10	7725495	STEERING MODULE SUB ASSY, OLY	1
11	7725695	MOTOR DRIVER, RESISTOR, MOUNTING ASSM, OLY	1
12	Z7725638	KIT, SENSOR, VEIN, BRACKET, SUB ASSEMBLY, OLY	1
13	7725640	STEPPER MOTOR, LAM, ASSY	1
14	Z7725703	KIT, TENSIONER ASM, OLYMPIA	1
15	7725376	BELT, HTD5MM, 100T X 15W	1
16	z7725271	ADJUST WRENCH, CUTTER, OLY	1
17	z7725417	LATCH, SOUTHCO, VIB RSISTANT, 10LBS	1
18	z7725412	BRACKET, DRAWER SWITCH, OLYMPIA	1
19	7725496	GUIDE, ALIGNMENT SENSOR, BOTTOM, OLY	1
20	1824002	NUT, KEPS, M3	4
21	7725641	BRACKET ASSY, ALIGNMENT SENSOR, OLY	1
22	7725375	PULLEY, TIMING, HTD5MM, 32T X 12MM BORE	1
23	1823603	SET SCREW, NYLON PATCH, M5X6	4
24	7725374	PULLEY, TIMING, HTD5MM, 32T X 1/2IN BORE	1
25	1824001	NUT, KEPS M4	2
26	7725376	BELT, HTD5MM, 100T X 15W	1
27	7729813	SERVICE, THREADLOCKER, RED	-
28	7725414	BRACKET, DRAWER SLIDE, RH, ASSY, OLY	1
29	7725415	BRACKET, DRAWER SLIDE, LH, OLY	1
30	7718047	DRAWER SLIDE ASSEMBLY, 550MM	3
31	1825605	BUTTON-HEAD SOCKET SCREW M4X8	12
32	7711970	Emitter	1
33	7711973	Reciever	1

PL 7.1 Cover Assembly

ITEM	PART #	DESCRIPTION	QTY
1	Z7726190	COVER, REAR, ASSEMBLY, OLY, XEROX	1
2	Z7725763	DOOR STRUT	1
3	Z776199	LATCH, BALL CATCH	1
4	Z7726225	WELDMENT, COVER, BRIDGE FRONT	1
5	7709736	COVER, UI ACCESS	1

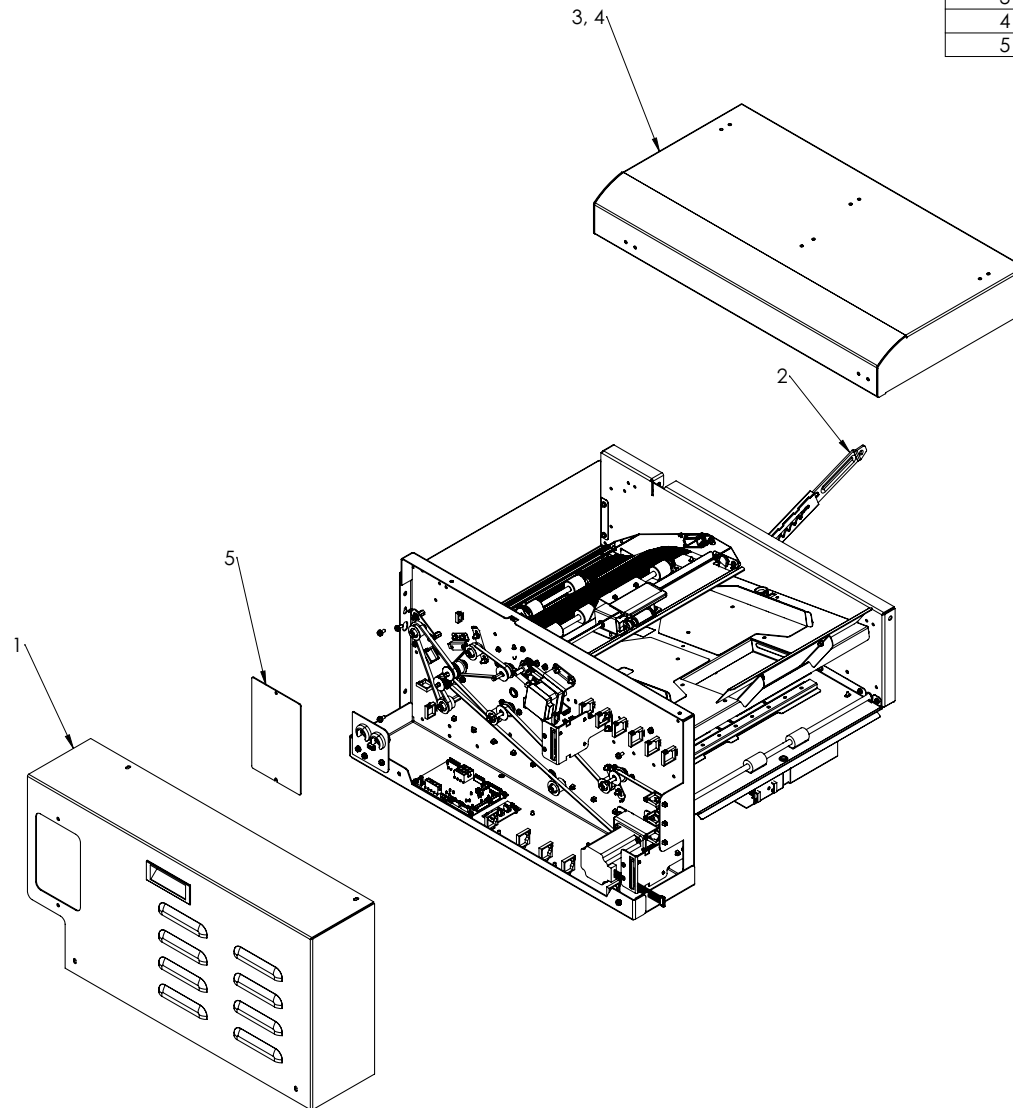

PL 7.2 Feeder

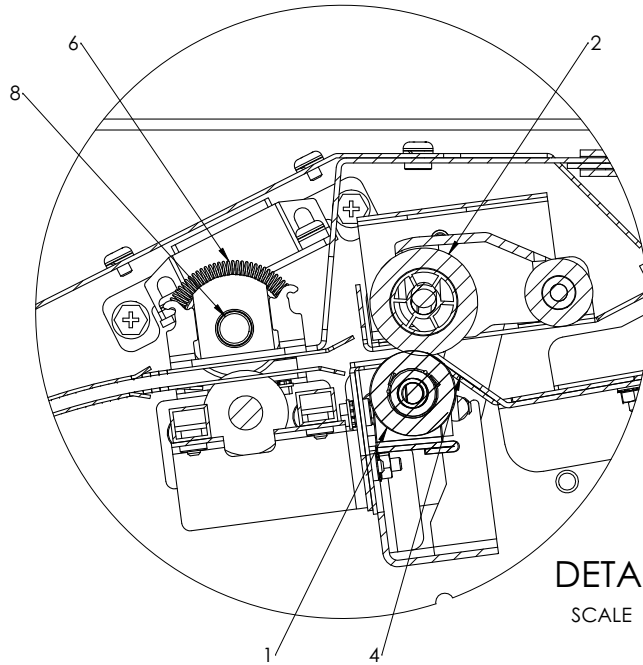

ITEM	PART #	DESCRIPTION	QTY
1	Z7726497	CLUTCH ROLLER ASSEMBLY	1
2	Z7726455	PICK ROLLER ASSEMBLY	1
3	7715193	SENSOR, PAPER PATH	3
4	7726457	FEEDER, MYLAR PAD	1
5	7715093	ROLLER ASSY, DRIVE	1
6	7715380	SPRING, TRANSPORT IDLER ROLLERS (7717410)	6
7	7715103	ROLLER ASSEMBLY IDLER	1
8	7726420	ROLLER ASSEMBLY, IDLER, NARROW	2
9	Z7729820	KIT, RACK AND PINION	1

DETAIL B
SCALE 1 : 1

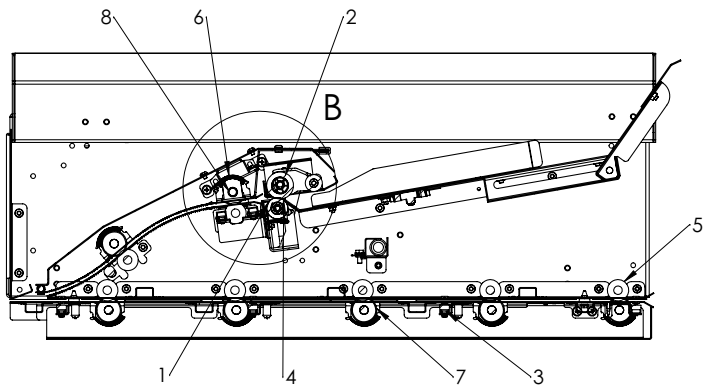

SECTION A-A
SCALE 1 : 4

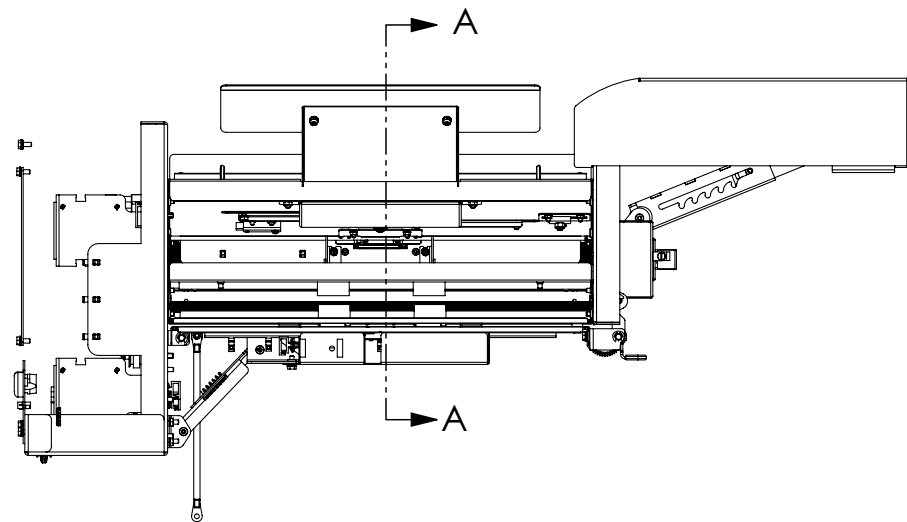

PL 7.2 Feeder

ITEM	PART #	DESCRIPTION	QTY
10	7725428	EXTENSION SPRING, 1" LONG, 0.25" O.D.	1
11	Z7716496	PULLEY, TIMING, 2MM 2GT, 30 GROOVES, ALUMINUM	7
12	7716552	PULLEY, 20G, 2MM-GT2, 6W	2
13	Z7729822	KIT, FEEDER	-

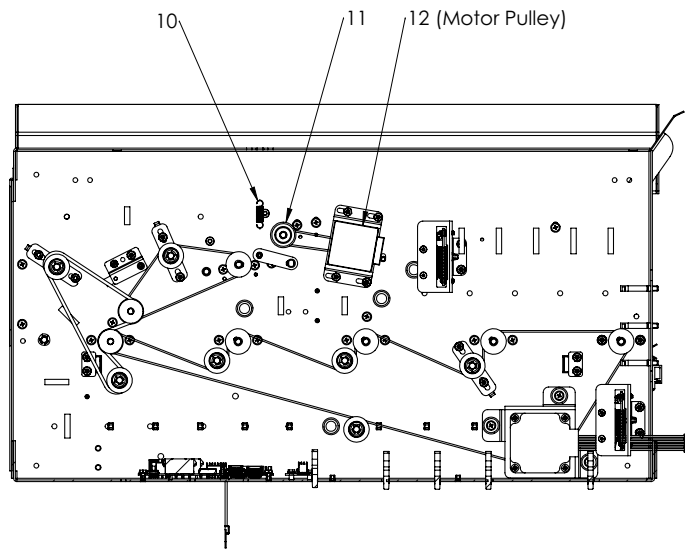

SECTION C-C
SCALE 1 : 4

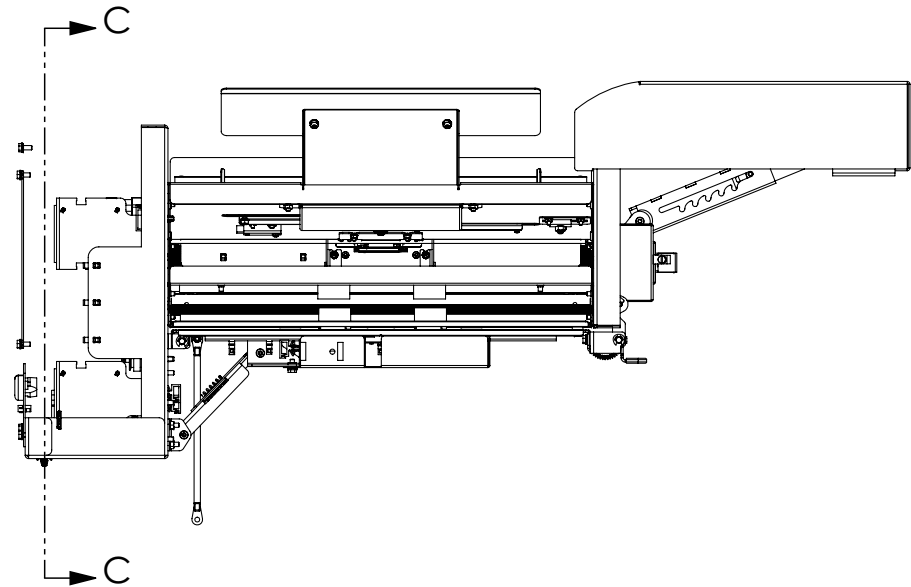

PL 7.3 Bridge

ITEM	PART #	DESCRIPTION	QTY
1	Z7726215	ASSEMBLY, LATCH, BRIDGE IDLER PANE	2
2	Z7726219	BRACKET, BRIDGE LATCH PIN	2
4	7715193	SENSOR, PAPER PATH	3
6	7610501	INTERLOCK SWITCH	1
7	Z7726349	STRUT ASSEMBLY, BRIDGE, OLYMPIA	2
8	7715817	WIRE SADDLE, SMALL, LOCKING TOP, V-O	-
9	7715819	WIRE SADDLE, LARGE, LOCKING TOP, V-O	-

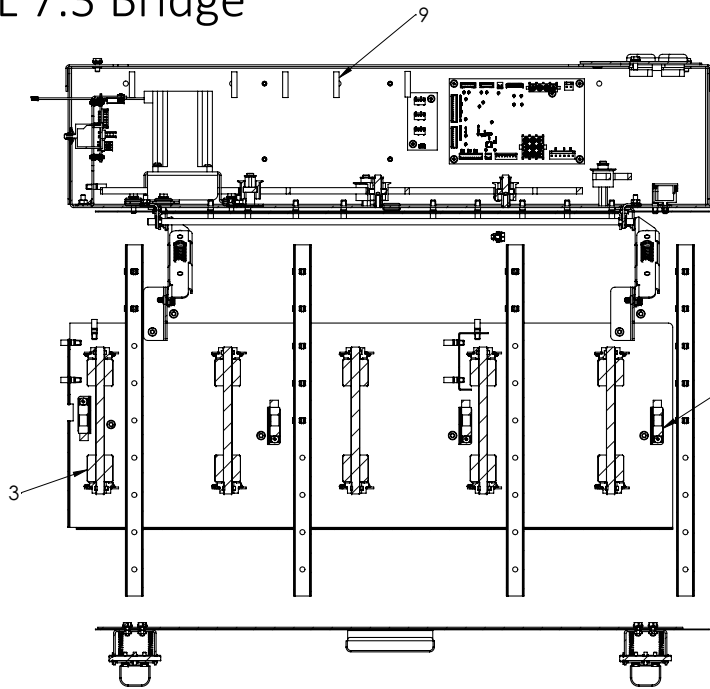

SECTION B-B
SCALE 1 : 4

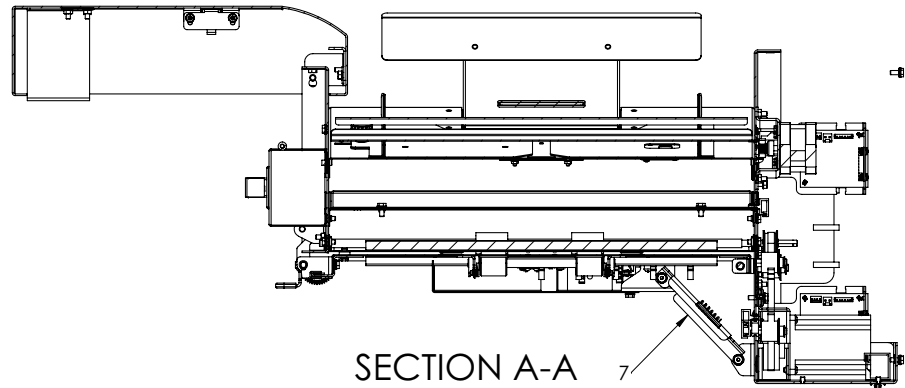
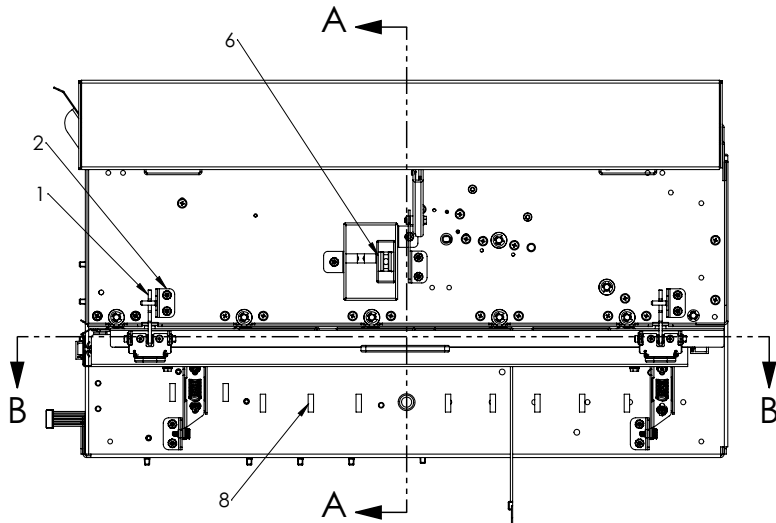

PL 7.3 Bridge

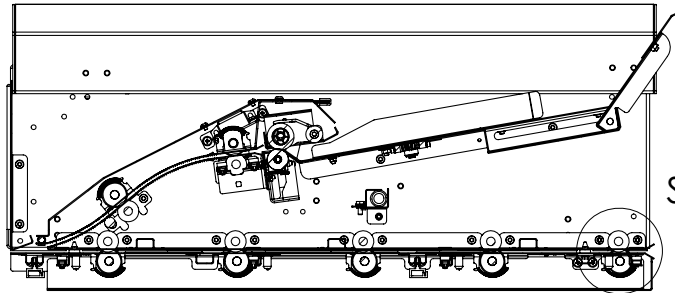

ITEM	PART #	DESCRIPTION	QTY
3	7715093	ROLLER ASSEMBLY DRIVE	1
5	7726264	SENSOR AND BRACKET ASSEMBLY, BRIDGE	1

SECTION C-C

SCALE 1 : 4

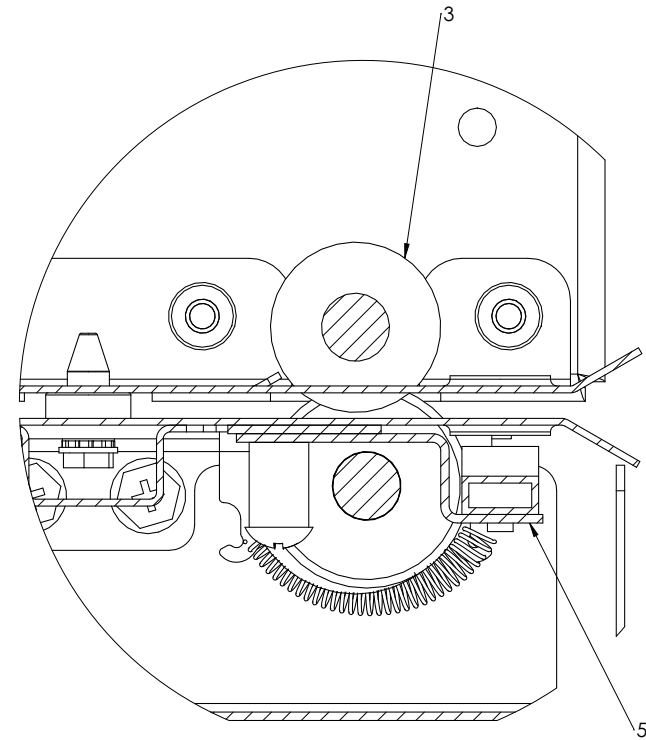
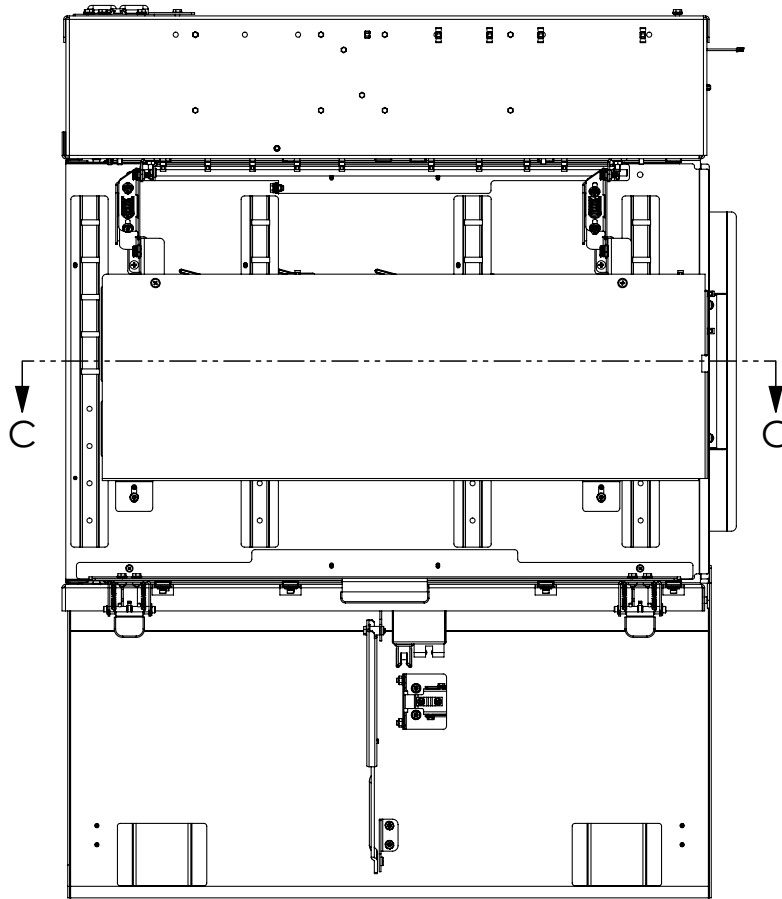

DETAIL D

SCALE 2 : 1

Cable Part Number Index

Item	Part No.	Description	Qty.
1	7717197	CABLE, STEPPER DRIVER TO MOTOR	2
2	7725150	CABLE, M9 MOTOR OLY	1
3	7725151	CABLE, BREAKOUT BOARD RELAY OLY	1
4	7725152	CABLE, S1B RECEIVER/EMITTER OLY	1
5	7725153	CABLE, 24V DC-to-DC CONVERTER OLY	1
6	7725155	CABLE, S22, S23 and S24 OLY	1
7	7725156	CABLE, M3/M4/M5 POWER OLY	1
8	7725159	CABLE, M3, M4 AND M5 DRV OLY	1
9	7725551	CABLE, SENSORS S1,S25,S26, OLY	1
10	7725552	CABLE, SENSORS S2,S3,S4,S5 OLY	1
11	7725553	CABLE, SENSORS, SKEW, BRD TO HDR OLY	1
12	7725554	CABLE, SENSORS, ALIGN, BRD TO HDR OLY	1
13	7725555	CABLE, SENSORS, BG & ALGN HM, BRD TO HDR OLY	1
14	7725685	CABLE, AC MOTOR TO HDR	1
15	7725557	CABLE, SENSORS, S22, S23, S24 OLY	1
16	7725558	CABLE, SOLENOIDS, ENTRY, BRD TO HDR OLY	1
17	7725559	CABLE, SOLENOIDS, EXIT, BRD TO HDR OLY	1
18	7725560	CABLE, STEPPER MOTOR DRIVERS, M1, M2 OLY	1

19	7725561	CABLE, STEPPER MOTOR DRIVER, M3, M4, M5 OLY	1
20	7725562	CABLE, STEPPER MOTOR DRIVER, M6, M7, M8 OLY	1
21	7725564	CABLE, POWER, STEPPER, DRIVERS OLY	1
22	7725565	CABLE, CHIP TRAY, Waste Bin Level Sensor OLY	1
23	7725566	CABLE, DOOR INTERLOCK OLY	1
24	7725567	CABLE, USB OLY	1
25	7725568	CABLE, DC POWER OLY	1
26	7725569	CABLE, AC TO PSU OLY	1
27	7725570	CABLE, AC TO Communication BOARD OLV	1
28	7725572	CABLE, INLET FILTER TO AC SWITCH OLY	1
29	7725573	CABLE, SKEW, HDR TO SENSOR OLY	1
30	7725574	CABLE, ALIGN, HDR TO SENSOR OLY	1
31	7725575	CABLE, BG, HDR TO SENSOR OLY	1
32	7725580	CABLE, AC FILTER, GROUND OLY	1
33	7725583	CABLE, THRU BEAM, S1B SENSOR OLY	1
34	7725584	CABLE, DEBUG TO PANEL OLY	1
35	7725585	CABLE, GROUND, PSU TO CHASSIS OLY	1
36	7725586	CABLE, DFA, UPSTREAM, OLY	2
37	7718585	2501CH-10	1
38	7724421	CABLE RIBBON TOUCHSCREEN, SPARTA 2.0	1
39	7725161	CABLE, CARTRIDGE DETECTION	1
40	7725510	CABLE, SWITCH, JUMPER, OLYMPIA	1

41	7725643	CABLE, M8 POWER, BOARD TO ARM	1
42	7725175	AC DRIVER ASSEMBLY POWER CABLE	1
43	7725653	CABLE, AC STEPPER DRIVER, HDR, TERMINAL	1
44	7715462	CABLE SENSOR 27	1
45	7725178	REGNERATIVE RESISTOR ASSY	1
46	7715476	CABLE, PUNCH MOTOR	1
47	7725640	STEPPER MOTOR, LAM, ASSY	1
49	7725684	CABLE, SOLENOID 6 TO HDR OLY	1
49	7718876	CABLE, PASS THROUGH, KM SPARTA	1
50	7726008	CABLE, MAIN HARNESS TO BRIDGE CONNECT, #18/22	1
51	7726009	CABLE, MAIN HARNESS TO BRIDGE CONNECT #28/30	1
52	7726010	CABLE, BRIDGE CONNECT TO NFX, #18/22	1
53	7726011	CABLE, BRIDGE CONNECT TO NFX, #28/30	1
54	7726012	CABLE, CABLE, NFX, STEPPER MOTOR DRIVERS	1
55	7726013	CABLE, CABLE, NFX, STEEPER MOTOR POWER	1
56	7726014	CABLE, CABLE, NFX SENSORS, TP SEN 16, TP SEN 17	1
57	7726015	CABLE, NFX SENSORS, S31, S32, S30	1
58	7726016	CABLE, CABLE SENSORS, TPSEN18, TPSEN19, TPSEN21	1
59	7726017	CABLE, CABLE, NFX, INTERLOCKS	1
60	7726018	CABLE, SPLITTER TO SENSOR	4
61	7726019	CABLE, S1, S25, S26 SPLIT, OLYMPIA	1

62	7726020	CABLE, DFA, DOWNSTREAM, OLYMPIA, XEROX	1
63	7715474	CABLE, JUMPER, STEPPER	2
64	7726021	CABLE, XEROX, INTERLOCK, HEADER TO SWITCH	1
65	7726022	CABLE, SENSOR, STACKER, OLYMPIA	1
66	7725185	CABLE, S33, MAIN TO PANEL, OLY	1
67	7725186	CABLE, S33, PANEL TO SENSOR, OLY	1

